



ALTIMATIC IIIC

Service Manual

PIPER AIRCRAFT CORPORATION

761 602

**Piper Aircraft Corporation, Vero Beach, Florida
U. S. A.**

Published by
PUBLICATIONS DEPARTMENT
Piper Aircraft Corporation
761 602
Issued: November 1974

REVISIONS ISSUED

Current, Permanent and Temporary Revisions to this AltiMatic IIC Service Manual issued November 1974 are as follows:

761 602 (PR750613)	Permanent Revision	Dated June 13, 1975
761 602 (PR770415)	Permanent Revision	Dated April 15, 1977
761 602 (PR780310)	Permanent Revision	Dated March 10, 1978
761 602 (PR780810)	Permanent Revision	Dated August 10, 1978
761 602 (PR791130)	Permanent Revision	Dated November 30, 1979
→ 761 602 (PR811016)	Permanent Revision	Dated October 16, 1981

FOREWORD

This Service Manual is provided as a guide for Removal and Installation, Troubleshooting Procedures, and Set-Up Procedures for the Piper AltiMatic IIC.

The information presented in this manual has been divided into three parts; Part I contains six (6) sections, Part II contains six (6) sections and Part III contains three (3) sections.

The information compiled in this manual will be kept current by revisions distributed periodically to the manual owner through their local Piper Dealer or Distributor.

REVISION

There will be two (2) types of revisions used to keep this manual current. The material compiled in these revisions will consist of information necessary to maintain the present AltiMatic IIC. Therefore, it is imperative that this material be inserted in the Service Manual at the time it is received.

I. Temporary Revision

This type revision will be distributed at any time it is necessary to forward Technical Servicing Information to the field. The temporary revision will usually consist of one or two pages which may be inserted in the front of the manual. These revisions will include deletions and additions of material pertinent to different paragraphs of the service manual. Therefore, when the temporary revision is received, review the manual and mark the affected paragraph with the code date of the latest revision for a ready reference.

II. Permanent Revision

This type revision will be distributed periodically and will supersede all previous temporary revisions. These revisions will be of complete page replacement and shall be inserted in the service manual in accordance with the following instructions:

1. Replace the obsolete pages with revised pages of the same page number.
2. Insert pages with page numbers followed by a small letter in direct sequence with the same common page number.
3. Insert pages with page numbers followed by a capital letter in direct sequence with the same common page number but after any pages with the same common page number followed by a small letter.

III. Identification of Revised Material

Revised text and illustrations shall be indicated by a black vertical line along the left-hand margin of the page opposite the change. A line opposite the page number or section title and printing date will indicate that the text or illustration was unchanged, but the material was relocated to a different page. Newly added material shall be identified by an arrow pointing toward either the text, text heading or illustration. When material is removed, an arrow will point away from the area from which the material was removed.

Symbols will indicate only current revisions with changes and additions to or deletions of existing text and illustrations. Changes in capitalization, spelling, punctuation or the physical location of the material on the page will not be identified by symbols.

TABLE OF CONTENTS

PART I ALTIMATIC IIIIC

I	INTRODUCTION AND DESCRIPTION	1-1
II	THEORY OF OPERATION	2-1
III	REMOVAL AND INSTALLATION	3-1
IV	TEST EQUIPMENT	4-1
V	SET-UP PROCEDURES	5-1
VI	WIRING DIAGRAMS	6-1

PART II GLIDE SLOPE COUPLER

VII	DESCRIPTION	7-1
VIII	THEORY OF OPERATION	8-1
IX	REMOVAL AND INSTALLATION	9-1
X	TEST EQUIPMENT	10-1
XI	BENCH SET-UP PROCEDURES	11-1
XII	GROUND CHECK AND FLIGHT SET-UP PROCEDURES	12-1

TABLE OF CONTENTS (cont.)

PART III ELECTRONIC PITCH TRIM

XIII	INTRODUCTION AND DESCRIPTION	13-1
XIV	THEORY OF OPERATION	14-1
→ XV	GROUND CHECK - ELECTRONIC PITCH TRIM SYSTEM	15-1
→ XVI	TROUBLESHOOTING.....	16-1

LIST OF ILLUSTRATIONS

Figure		Page
2-1.	AltiMatic IIC Block Diagram	2-5
3-1.	Roll, Rudder and Pitch Servo Guide	3-3
3-2.	Bridle Cable Clamp Installation	3-4
3-3.	PA-23-250 (Six Place) E & F Models AltiMatic IIC Layout	3-7
3-4.	PA-31-310, PA-31-325, PA-31-350 and PA-31P AltiMatic IIC Layout	3-8
3-5.	PA-32-260, PA-32-300, PA-32R-300, PA-32RT-300, PA-32RT-300T, PA-32-301, PA-32-301T, PA-32R-301 and PA-32R-301T AltiMatic IIC Layout	3-9
3-6.	PA-34-200T AltiMatic IIC Layout	3-10
3-7.	PA-44-180 AltiMatic IIC Layout	3-11
3-7a.	PA-28RT-201 and PA-28RT-201T AltiMatic IIC Layout.....	3-12
3-8.	Roll Servo Cable Tension Diagram	3-13/ 3-14
3-9.	Pitch and Rudder Servo Cable Tension Diagram	3-15/ 3-17
3-10.	AltiMatic IIC Console	3-19
3-11.	AltiMatic IIC, Electronic Trim Amplifier and Autopilot Amplifier	3-21
3-12.	AltiMatic IIC, Attitude Gyro	3-22
3-13.	AltiMatic IIC, Directional Gyro/Horizontal Situation Indicator	3-23
3-14.	AltiMatic IIC, Altitude Hold Unit and Relay Box	3-24
3-15.	Roll Servo Installation, PA-23-250 (Six Place) E & F Models	3-25
3-16.	Pitch Servo Installation, PA-23-250 (Six Place) E Model	3-27
3-17.	Pitch Servo Installation, PA-23-250 (Six Place) F Model	3-29
3-18.	Pitch Trim Servo Installation, PA-23-250 (Six Place) E & F Models	3-31
3-19.	AltiMatic IIC, Gyro Slaving Amplifier.....	3-32
3-20.	AltiMatic IIC, Flux Detector	3-32
3-21.	AltiMatic IIC, NAV Converter (1C707)	3-33
3-22.	Roll Servo Installation, PA-31-310, PA-31-325, PA-31-350 and PA-31P	3-38
3-23.	Pitch Servo Installation, PA-31-310, PA-31-325, PA-31-350 and PA-31P.....	3-39
3-24.	Rudder Servo Installation, PA-31-310, PA-31-325, PA-31-350 and PA-31P.....	3-41
3-25.	Pitch Trim Servo Installation, PA-31-310, PA-31-325, PA-31-350 and PA-31P	3-43
3-26.	Yaw Damper Amplifier Installation, PA-31-310, PA-31-325, PA-31-350 and PA-31P	3-44
3-27.	Roll Servo Installation, PA-32-260, PA-32-300, PA-32R-300, PA-32RT-300, PA-32RT-300T, PA-32-301, PA-32-301T, PA-32R-301, PA-32R-301T, PA-28RT-201 and PA-28RT-201T.....	3-51
3-28.	Pitch Servo Installation, PA-32-260, PA-32-300, PA-32R-300, PA-32RT-300, PA-32RT-300T, PA-32-301, PA-32-301T, PA-32R-301, PA-32R-301T, PA-28RT-201, PA-28RT-201T and PA-44-180.....	3-54
3-29.	Pitch Trim Servo Installation, PA-32-260, PA-32-300, PA-32R-300, PA-32RT-300, PA-32RT-300T, PA-32-301, PA-32-301T, PA-32R-301, PA-32R-301T, PA-28RT-201 and PA-28RT-201T.....	3-57
3-30.	Roll Servo Installation, PA-34-200T and PA-44-180.....	3-63
3-31.	Pitch Servo Installation, PA-34-200T	3-65
3-32.	Pitch Trim Servo Installation, PA-34-200T.....	3-66

LIST OF ILLUSTRATIONS (cont)

Figure		Page
3-33.	Altitude Hold Unit Installation (1C725)	3-70
3-34.	Relay Box Installation, PA-44-180	3-71
3-35.	Pitch Trim Servo Installation, PA-44-180	3-73
3-36.	NAV Flag Adapter Installation	3-80
3-37.	KA-52 Autopilot Adapter Installation	3-81
4-1.	Gyro Substitute	4-2
4-2.	Power Section	4-2
4-3.	Console Substitute	4-3
4-4.	Radio Coupler Tester	4-5
4-5.	Block Diagram of 66D141 Test Kit	4-6
5-1.	AltiMatic IIC Console	5-5
5-2.	AltiMatic IIC, 1C515-1/1C515-3 Amplifier Threshold Adjustment Potentiometers	5-7
5-3.	Power Section Test Box	5-13
5-4.	Extension Test Cables	5-15
5-5.	Radio Coupler Power Cable	5-16
5-6.	Radio Coupler Adjustment Points	5-29
5-7.	Piper Omni/Localizer Coupler Modification Detail	5-33
5-8.	NAV Converter (1C707) Adjustment Potentiometers	5-34
5-9.	Sample Deviation Charts	5-38
5-10.	Slaving Amplifier, N-S/E-W Corrector Adjustment Potentiometers	5-39
5-11.	In-Line Test Box (Locally Fabricated)	5-41
5-12.	KA-52 Autopilot Adapter	5-42
→ 5-13.	Bench Test Wiring Harness - Yaw Damper	5-44
→ 5-14.	Test Equipment Hook-Up - Yaw Damper	5-44
6-1.	AltiMatic IIC Block Diagram, PA-23-250 (Six Place) E & F (up to S/N 27-7754002) Models	6-2
6-2.	AltiMatic IIC Block Diagram, PA-23-250 (Six Place) F Models, S/N 27-7754003 and up	6-3
6-3.	AltiMatic IIC Block Diagram, PA-31-310 and PA-31-325	6-4
6-4.	AltiMatic IIC Block Diagram, PA-31-350	6-5
6-5.	AltiMatic IIC Block Diagram, PA-31P	6-6
6-6.	AltiMatic IIC Block Diagram, PA-32-260, PA-32-300, PA-32R-300, PA-32RT-300 and PA-32RT-300T	6-7
6-7.	AltiMatic IIC Block Diagram, PA-34-200T and PA-44-180	6-8
6-8.	AltiMatic IIC Harness	6-9
6-8a.	Yaw Damper Block Diagram, PA-31-310, PA-31-325 and PA-31-350	6-10
6-8b.	Yaw Damper Block Diagram, PA-31P	6-10
6-9.	Yaw Damper Harness (Optional)	6/11/6-11a
6-10.	Horizontal Situation Indicator Harness (Optional) with 1C707	6-12
6-11.	Horizontal Situation Indicator Harness (Optional) without 1C707	6-13
6-11a.	Horizontal Situation Indicator (Optional) with RNAV	6-14
6-12.	Horizontal Situation Indicator Schematic Slaved (Optional)	6-15
6-13.	Electronic Trim System Schematic	6-16
6-14.	Servo Schematic	6-17
6-15.	Relay Box Schematic	6-17

LIST OF ILLUSTRATIONS (cont)

Figure		Page
6-16.	Altitude Hold Unit Schematic	6-17
6-17.	AltiMatic IIC Pressure Bulkhead Connectors (PA-31P)	6-18/ 6-19
6-18.	Servo, AltiMatic IIC A/P Harness, PA-23-250 (Six Place)	6-20
6-19.	HSI Harness, PA-23-250 (Six Place)	6-21
6-20.	Converter Harness, PA-23-250 (Six Place)	6-22
6-21.	Radio Coupler Harness, PA-23-250 (Six Place)	6-23
6-22.	Gyro Slaving Harness, PA-23-250 (Six Place)	6-24
6-23.	Slaving Switch Harness, PA-23-250 (Six Place)	6-25
6-24.	RMI Boot Strap Harness, PA-23-250 (Six Place)	6-26
6-25.	Flux Sensor Harness, PA-31-310; -325; -350 and PA-31P	6-26
6-26.	HSI, EDO-AIRE Mitchell Harness, PA-31-310; -325 and -350	6-27
6-27.	HSI, EDO-AIRE Mitchell Harness, PA-31-310; -325 and -350	6-28
6-28.	Compensator Harness, PA-31-310; -325; -350 and PA-31P	6-29
6-29.	Gyro Slaving Harness, PA-31-310; -325 and -350	6-30
6-30.	Boot Strap Harness, PA-31-310; -325; -350 and PA-31P	6-31
6-31.	Plug Bracket Schematic for AltiMatic IIC (PA-31)	6-33
6-32.	HSI, EDO-AIRE Mitchell Harness, PA-31P	6-34/ 6-35
7-1.	AltiMatic IIC Glide Slope Coupler Approach	7-1
8-1.	Pitch Axis Control System with Glide Slope Coupler	8-1
8-2.	Block Diagram of AltiMatic IIC with Glide Slope Coupler	8-3
8-3.	Glide Slope Coupler Block Diagram	8-4
9-1.	Glide Slope Coupler Installation, PA-23-250 (Six Place) E & F Models	9-3
9-2.	Glide Slope Coupler Installation, PA-31-310, PA-31-325 and PA-31-350	9-3
9-3.	Glide Slope Coupler Installation, PA-31P	9-4
9-4.	Glide Slope Coupler Installation, PA-32-260, PA-32-300, PA-32R-300, PA-32RT-300, PA-32RT-300T, and PA-34-200T	9-4
9-5.	Glide Slope Coupler Installation, PA-44-180	9-5
10-1.	Glide Slope Coupler Test Cables and Jumper Plug	10-3
11-1.	Glide Slope Coupler	11-3
11-2.	Glide Slope Coupler Harness Schematic	11-5/ 11-6
11-3.	Plug Bracket Schematic for AltiMatic IIC with Glide Slope Coupler, PA-31	11-7/ 11-8
→ 15-1.	AutoPilot Manual Electric Trim	15-1

LIST OF TABLES

Table		Page
III-I.	AltiMatic IIIC Trim Servo Clutch Tension	3-2
III-II.	AltiMatic IIIC Applicability Chart	3-5
IV-I.	Trouble Isolation Block Diagram	4-7
V-I.	Roll Threshold	5-11
V-II.	Pitch Threshold	5-11
→ V-III.	Trouble Isolation Block Diagram	5-43
X-I.	Trouble Isolation Block Diagram	10-2
→ XVI-I.	Trouble Isolation Block Diagram	16-1

PART I

ALTIMATIC IIC

SECTION I

INTRODUCTION AND DESCRIPTION

Paragraph		Page
1-1.	Introduction	1-1
1-2.	Description	1-1

SECTION I

INTRODUCTION AND DESCRIPTION

1-1. INTRODUCTION. This part of the service manual is divided into six sections. Section I contains a description of the AltiMatic IIC. Section II, Theory of Operation, explains the theory of the Automatic Flight Control System including the Radio Coupling. Section III, Removal and Installation, provides the information necessary for removal and installation of all AltiMatic IIC components. Section IV, Test Equipment, provides information on the equipment used to verify, adjust and troubleshoot the system. Section V, Set-Up Procedures, provides the information necessary to perform a sequential test of the system and Bench, Ground and Flight adjustments. Section VI, Wiring Diagrams, provides the information for the AltiMatic IIC electrical cables and harnesses used for interconnecting the system.

1-2. DESCRIPTION. The Piper AltiMatic IIC Automatic Flight Control System is designed to provide smooth operation and high reliability with the minimum complexity possible in order to satisfy present day operational requirements. Design techniques and components utilized represent the latest advances in the state of the art both in electronics and lightweight flight control systems. Except for air driven gyro instruments, the system operates from the airplane DC electrical system.

The AltiMatic IIC is a complete 3-axis, two surface Autopilot, (3-axis, three surface Autopilot if optional YAW Damper is installed) designed for the heavier single and light to medium twin engine airplanes. The system automatically maneuvers the airplane in response to a preselected flight profile selected by the pilot. The AltiMatic IIC Autopilot features pitch, roll and optional yaw attitude, altitude, heading and automatic pitch trim. With the pitch axis engaged, the Autotrim System keeps the pitch trim properly set at all times. This not only enhances the ability of the system to fly the airplane, but also improves safety by providing for the airplane to be turned over to the pilot in a trimmed condition when the Autopilot is disengaged.

The AltiMatic IIC incorporates a totally electronic Autotrim system that electronically senses trim requirements and adjusts the trim as required. This is a solid state unit which replaces the mechanical trim sensor used in previous III Series systems. This system offers reduced maintenance and installation complexity. However, it requires greater time to totally resolve minor trim forces. Occasionally, when disengaging the Autopilot a slight bump may be felt in the controls if insufficient time has elapsed for total trim action to be accomplished.

With the installation of optional radio couplers in conjunction with the AltiMatic IIC Autopilot, the system offers the additional feature of ILS/VOR coupling. The radio coupler is a special purpose analog computer which causes the system to fly with reference to a radio defined path.

The AltiMatic IIC utilizes a 1C515-1 or 1C515-3 computing amplifier which incorporates a roll and a pitch threshold adjustment. There is no airspeed limiting feature in this system as in previous III Series Autopilots. With the addition of threshold adjustments, the system has greater adaptability. There is no Altitude Preselect in this system as in previous III Series Autopilots. However, the system incorporates an Altitude Hold Mode which requires no pitch command adjustment prior to engagement.

The AltiMatic IIC Autopilot disengage button is incorporated in the trim switch located on the pilot's control wheel which energizes the Autopilot Disengage Relay. The Disengage Relay interrupts A+ to the Autopilot, permitting the magnetically held Roll Switch to release and turn "OFF" the Autopilot. The AltiMatic IIC is also equipped with a Master Trim Disconnect/Interrupt Switch on the pilot's control wheel. When this switch button is depressed it will disconnect the Autopilot and Yaw Damper if installed. When depressed and held it will interrupt all Electric Elevator Trim Operations. Trim operation will be restored when the switch is released.

SECTION II

THEORY OF OPERATION

Paragraph	Page
2-1. Piper Altimate IIC Automatic Flight Control System	2-1
2-2. Console	2-1
2-3. Amplifier	2-1
2-4. Gyros	2-1
2-5. Horizontal Situation Indicator (Non-Slaved) (Optional)	2-2
2-6. Horizontal Situation Indicator (Slaved) (Optional)	2-2
2-7. Yaw Damper System (Optional)	2-3
2-8. Roll, Yaw (Optional), and Pitch Servos	2-3
2-9. Pitch Trim Servo	2-3
2-10. Altitude Controller	2-3
2-11. Modes of Operation	2-3
2-12. Roll Mode	2-3
2-13. Heading Mode	2-3
2-14. Pitch Mode	2-4
2-15. Altitude Hold Mode	2-4
2-16. Lateral Guidance System (Radio Coupler)	2-4
2-17. Omni Mode	2-4
2-18. Nav Mode	2-4
2-19. Heading Mode	2-4
2-20. Localizer (Normal) Mode	2-4
2-21. Localizer (Reverse) Mode	2-4

SECTION II

THEORY OF OPERATION

2-1. PIPER ALTIMATIC IIC AUTOMATIC FLIGHT CONTROL SYSTEM. The Piper AltiMatic IIC Autopilot incorporates several unique concepts and circuits which provide smooth operation, simplified installation and maintenance, and high reliability. The most significant is the computing amplifier which eliminates the need for a control surface follow-up element.

The Piper AltiMatic IIC Autopilot may be operated from either a 14-volt DC or a 28-volt DC airplane electrical system. To understand the operation of the Piper AltiMatic IIC Autopilot, refer to the block diagram in Figure 2-1. The various options to the system are also shown in Figure 2-1. The following paragraphs present a theoretical description of the components of the Piper AltiMatic IIC Autopilot.

2-2. CONSOLE. The flight profile is programmed by the pilot at the console and modified at his discretion. The console can be considered as a funnel for all inputs to the Computing Amplifier during Autopilot operation, and all service set-up adjustments are also located on the console. For information pertaining to set-up adjustments, refer to Section V of this manual. If the system employs radio coupling, the pilot selects the mode of operation at the coupler. The console provides Autopilot engagement, Roll, Heading, Pitch and Altitude Hold modes of operation, also the Pitch Effort Meter, Pitch Command Disc and the Roll Command Knob. Various combinations of mode selection through individual mode switches are also available to the operator.

NOTE

The Operator's Manual for the Piper AltiMatic IIC Autopilot must be studied in depth by the serviceman if he is to interpret the indications and functions of the system in a manner to affect proper repairs and determine corrective action if and when required to the system.

2-3. AMPLIFIER. The computing amplifier, as in previous Piper Automatic Flight Control Systems Equipment, processes all input information according to the program modes selected by the pilot. The amplifier also contains the threshold adjustments required for the AltiMatic IIC Autopilot. The amplifier is required to furnish a power output to both the roll and pitch servo motors during autopilot operation. The autopilot mode of operation is controlled through the autopilot disengage relay. The autopilot can be disabled by the operator by pressing the control wheel mounted Master Trim Disconnect/Interrupt Switch which also disengages the optional Yaw Damper and interrupts electric trim operation or by pressing the disengage button incorporated in the control wheel mounted trim switch. Pressing either switch actuates the relay.

2-4. GYROS. Employed in the Piper AltiMatic IIC are three inch lightweight gyros. The Attitude Indicator and Directional Gyro are air-driven and supply attitude and heading signals to the amplifier. The Directional Gyro incorporates the heading Preselect feature, hereafter referred to as the Heading Bug. The air to these gyros passes through a filter. Periodically, this filter should be changed to increase gyro life, and insure correct performance.

On some installations the DG-360 is used in lieu of the standard Directional Gyro. The DG-360 is an

integrated instrument combining an air-driven gyro and an electrically servo'd heading card. Loss of either air or electric power will cause the red HDG flag to be visible. Also incorporated in the DG-360 is the A/P Radio Course Arrow which must be set to match the desired VOR/ILS course as selected on the Omni Bearing Selector.

2-5. HORIZONTAL SITUATION INDICATOR (Non-Slaved) (Optional). The AltiMatic IIC may utilize the optional non-slaved HSI in lieu of the standard Directional Gyro. The HSI is an integrated instrument combining an air-driven gyro and an electrically servo'd heading card with VOR/Localizer and Glide Slope information in addition to visual display. The HSI provides aircraft heading and course data to the system, and course information for VOR/ILS procedures during Autopilot operation. This instrument incorporates conventional warning flags which function as follows: The Heading (HDG) Flag which will retract from view when the instrument is receiving proper vacuum and electrical power. The "NAV" flag which will retract from view once a VOR or LOC frequency is tuned in and a reliable signal is received. The Glide Slope Flag which will retract from view when an ILS frequency is channeled and a reliable Glide Slope signal is present.

2-6. HORIZONTAL SITUATION INDICATOR (Slaved) (Optional). The AltiMatic IIC may utilize the optional slaved HSI in lieu of the standard Directional Gyro. This instrument offers all the features of the non-slaved HSI as outlined in Paragraph 2-5. However, the slaved HSI which requires initial heading setting on start up receives corrected heading information from the Slaving Sub-System and subsequent resetting of the heading card, required manually on non-slaved versions, is accomplished automatically.

The Slaving Sub-System is equipped with a dual channel Slaving Amplifier and a Flux Detector. The Slaving Meter and Slaved Directional Gyro are incorporated in the HSI. This system combines the desirable long term accuracy of a magnetic compass and the short term accuracy and stability of a gyro compass, thus eliminating the undesirable characteristics of short term oscillation of the magnetic compass and long term drift of the gyro compass.

The Flux Detector can be considered as a magnetic compass. The device is sensitive and reacts to the magnetic flux field surrounding the earth as does any magnetic compass. Due to the specialized construction of the Flux Detector, the seven (7) errors common to the standard aircraft magnetic compass are reduced if not eliminated. Also, of prime importance are stocking considerations. The Flux Detector must be stored to avoid areas of magnetic interference such as: radar energy transmissions, other flux detectors, transformers and any devices emitting electromagnetic radiation or magnetism.

The dual channel Slaving Amplifier is the next device within the Slaving Sub-System. The Flux Detector being a magnetic sensing device passes its output through both channels of the Slaving Amplifier. The North-South/East-West Compensator, incorporated in the slaving amplifier, corrects the output of the Flux Detector for deviations due to both electrical and physical locating errors. The N-S/E-W Compensator has two adjustments, one for North-South and one for East-West. These adjustments correct for minor Flux Detector errors and are normally made following the installation of the Slaved Sub-System. When aligning the system refer to Section V of this manual for the proper procedure.

The Slaved Directional Gyro incorporated in the HSI provides the stable gyroscopic system information. The activities of the gyro are controlled automatically. For example, instead of the human pilot visually observing gyro compass and magnetic compass readings and then caging and resetting the gyro, the Flux Detector and the North-South/East-West Corrector (incorporated in the Slaving Amplifier) provide constant magnetic reference information to the gyro unit. If an error exists, it is automatically corrected electrically. The corrective activities are continuous and are visually displayed to the human pilot by means of the Slaving Meter.

The Slaving Meter indicates the direction, length of time, and frequency of errors being eliminated by oscillating about a 45° point to show that the slaving circuits are accomplishing their function. Should the needle remain motionless or either vertical or horizontal for an extended period (two minutes) in level flight, the heading should be manually set using the magnetic compass and the performance of the heading card observed. If slaving difficulties are encountered, set the slaving mode switch to SL 2 or free gyro. In

free gyro mode the instrument must be periodically reset to manually counteract the effects of gyro precession.

2-7. **YAW DAMPER SYSTEM (Optional).** The Yaw Damper System is a frequently installed option with the AltiMatic IIC Autopilot. The system has a panel mounted push ON push OFF control switch. The system can be disengaged by placing the panel mounted switch in the OFF position or by momentarily pressing the control wheel mounted Master Trim Disconnect/Interrupt Switch. The system includes an electric rate gyro sensing element, an electronic solid state servo amplifier and the rudder servo. The sensitive signals of a rate gyro are combined with those of an electrolytic potentiometer which acts as a pendulum. The composite signals are tuned to the natural yaw frequency of the aircraft for maximum performance. The system gyro is energized through the main aircraft electrical bus and receives power any time the aircraft master switch is on.

2-8. **ROLL, YAW (OPTIONAL), AND PITCH SERVOS.** The Roll, Yaw and Pitch Servos of the Piper AltiMatic IIC are electrical servos similar to the Autopilot servos used in previous Piper Automatic Flight Control Systems equipment. The servos engage electrically and are easily overridden. If the electrical system fails, they automatically disengage.

2-9. **PITCH TRIM SERVO.** As in previous Piper Automatic Flight Control Systems equipment, the Electric Pitch Trim Servo receives electrical power from both a manual and automatic source. When the Autopilot function of the AltiMatic IIC is not used, the Pitch Trim Servo furnishes Manual Electric Trim via the control wheel trim switch. The panel mounted Trim Master Switch must be placed in the ON position for manual electric trim operation. When the Autopilot function is engaged, control of the Pitch Trim Servo reverts to Automatic Electric Pitch Trim via the electronic Autotrim system that electronically senses trim requirements and adjusts the trim as required. There is only one (1) Electric Pitch Trim Servo in the system, the trim servo shown in Figure 2-1 in two (2) blocks only to indicate the servo operates independently in one (1) of two (2) modes. The remainder of pertinent information for the Piper AltiMatic IIC Electric Pitch Trim System is covered in Part III of this manual.

2-10. **ALTITUDE CONTROLLER.** The Piper AltiMatic IIC Autopilot does not offer altitude preselect as did previous III Series Piper pitch axis Automatic Flight Control Systems equipment. The Altitude Controller features Altitude Hold which may be activated any time the Autopilot is engaged by simply placing the ALT Hold rocker switch (on the console) in the ON position. The pilot can reject this input by placing the ALT Hold rocker switch in the OFF position or by disengaging the Autopilot.

2-11. **MODES OF OPERATION.** Following is a brief description of the different modes of operation of the AltiMatic IIC Autopilot. The engage button for each mode of operation is explained in the following paragraphs.

2-12. **ROLL MODE.** Because Roll is first in logical sequence, the Roll engage acts as the Autopilot master switch. As such, the Roll must be engaged for all other engage and mode switches to become operative. With the Roll switch only engaged, the Autopilot is responsive only to the roll axis of the Attitude Gyro and the commands of the Roll Command Knob. Use of the Roll Command Knob permits bank angles up to 30° on the AltiMatic IIC.

2-13. **HEADING MODE.** The function of the Heading Mode Switch is to remove the Roll Command Knob from the Autopilot circuit and add the Directional Gyro or Horizontal Situation Indicator Heading Command and Coupler functions to the basic Roll Attitude control. Prior to engagement of the heading mode, the Heading Bug of the D.G. or HSI and Coupler Modes should be set. (See Coupler Mode, Paragraph 2-16.)

2-14. **PITCH MODE.** The Pitch Mode Switch engages the Autopilot pitch servo and makes the Autopilot responsive to the Pitch Attitude of the Gyro Horizon and the commands of the Pitch Command Disc. Attitude changes may be made by rotating the pitch command disc in the appropriate direction. Design of the system is such that commanded attitudes remain constant throughout power changes and gear and flap transitions.

2-15. **ALTITUDE HOLD MODE.** The function of the Altitude Hold Mode Switch is to remove the Pitch Command Disc from the Autopilot circuit and initiate a smooth transition to the pressure altitude at which it was engaged.

2-16. **LATERAL GUIDANCE SYSTEM. (Radio Coupler)** The radio coupler contains a five position switch which selects the desired mode of lateral guidance.

2-17. **OMNI MODE.** When the Omni Mode is selected, the Autopilot is coupled to the NAV and Omni/Converter CDI. When the D.G. Heading Bug or the HSI Course Arrow is set to match the Omni course selection, all headings are then controlled by the Omni Radio Signals. Intercept and track are automatic.

2-18. **NAV MODE.** The NAV mode extends the coupler utility by making operation practical under the adverse conditions of unsteady or erratic Radio Omni Signals. This mode incorporates an extended time delay in the circuitry which reduces Autopilot reaction to short term needle deflections of the Omni. The NAV mode should not be used for close in Omni approach work.

2-19. **HEADING MODE.** When in the HDG Mode, the Autopilot will function as described in Paragraph 2-13.

2-20. **LOCALIZER (NORMAL) MODE.** In the Loc Norm Mode, the coupler dynamics are set for optimum performance in tracking the localizer beam which is only 1/4 as wide as the Omni beam. Intercept and track are automatic as in the Omni Mode.

2-21. **LOCALIZER (REVERSE) MODE.** This mode permits automatic **BACK COURSE** approaches and outbound tracking on the **FRONT COURSE** prior to procedure turn. The features of back course are identical to front course except that the Autopilot response will be in reverse to the localizer indications and the Course Selector Directional Gyro must be set to the reciprocal of the front course heading. (For exceptions see **CAUTION** note.)

CAUTION

On installations incorporating the optional Horizontal Situation Indicator, when operating in the NAV mode, the HSI always gives the correct display if the heading card is matched to the magnetic heading. When operating in the Localizer mode, the course arrow of the HSI should be placed on the **INBOUND** front course heading. The display will then be correct for either front course or back course. During **Back Course Approaches**, the display will be inverted and the tail of the course arrow will indicate the back course heading. The Left/Right needle sensing will require turns toward the needle for course center line.

Figure 2-1. AltMatic III Block Diagram

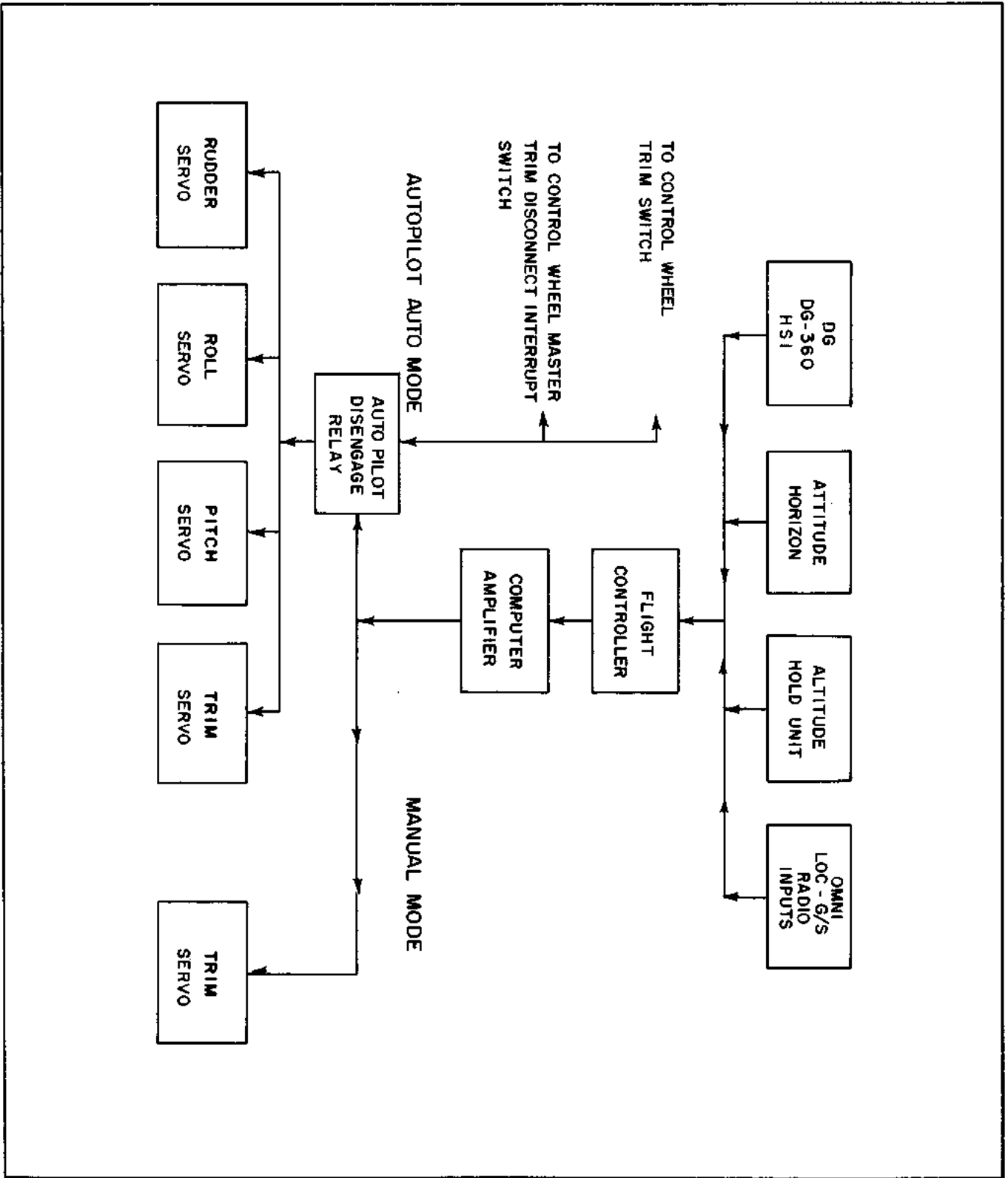

SECTION III

REMOVAL AND INSTALLATION

Paragraph		Page
3-1.	Introduction	3-1
3-2.	Pre-Installation Check and Adjustments of Roll, Yaw and Pitch Servo Assemblies	3-1
3-3.	Console (AltiMatic IIIC)	3-19
3-4.	Removal of Console (PA-23-250 Six Place) E & F Models	3-19
3-5.	Installation of Console (PA-23-250 Six Place) E & F Models	3-19
3-6.	Removal of Autopilot Amplifier (PA-23-250 Six Place) E & F Models	3-20
3-7.	Removal of Electronic Trim Amplifier (PA-23-250 Six Place) E & F Models	3-20
3-8.	Installation of Electronic Trim Amplifier (PA-23-250 Six Place) E & F Models	3-20
3-9.	Installation of Autopilot Amplifier (PA-23-250 Six Place) E & F Models	3-20
3-10.	Removal of Attitude Gyro (PA-23-250 Six Place) E & F Models	3-20
3-11.	Installation of Attitude Gyro (PA-23-250 Six Place) E & F Models	3-21
3-12.	Removal of Directional Gyro and/or Horizontal Situation Indicator (PA-23-250 Six Place) E & F Models	3-22
3-13.	Installation of Directional Gyro and/or Horizontal Situation Indicator (PA-23-250 Six Place) E & F Models	3-23
3-14.	Removal of Altitude Hold Unit (PA-23-250 Six Place) E & F Models	3-23
3-15.	Installation of Altitude Hold Unit (PA-23-250 Six Place) E & F Models	3-24
3-16.	Removal of Relay Box (PA-23-250 Six Place) E & F Models	3-24
3-17.	Installation of Relay Box (PA-23-250 Six Place) E & F Models	3-24
3-18.	Removal of Roll Servo (PA-23-250 Six Place) E & F Models	3-25
3-19.	Installation of Roll Servo (PA-23-250 Six Place) E & F Models	3-25
3-20.	Removal of Pitch Servo (PA-23-250 Six Place) E & F Models	3-26
3-21.	Installation of Pitch Servo (PA-23-250 Six Place) E Model	3-26
3-22.	Installation of Pitch Servo (PA-23-250 Six Place) F Model	3-28
3-23.	Removal of Pitch Trim Servo (PA-23-250 Six Place) E & F Models	3-30
3-24.	Installation of Pitch Trim Servo (PA-23-250 Six Place) E & F Models	3-30
3-25.	Removal of Gyro Slaving Amplifier (PA-23-250 Six Place) E & F Models	3-31
3-26.	Installation of Gyro Slaving Amplifier (PA-23-250 Six Place) E & F Models	3-31
3-27.	Removal of Flux Detector (PA-23-250 Six Place) E & F Models	3-31
3-28.	Installation of Flux Detector (PA-23-250 Six Place) E & F Models	3-33
3-29.	Removal of NAV Converter (1C707) (PA-23-250 Six Place) E & F Models	3-33
3-30.	Installation of NAV Converter (1C707) (PA-23-250 Six Place) E & F Models	3-33
3-31.	Removal of Console (PA-31-310, PA-31-325, PA-31-350 and PA-31P)	3-34
3-32.	Installation of Console (PA-31-310, PA-31-325, PA-31-350 and PA-31P)	3-34
3-33.	Removal of Autopilot Amplifier (PA-31-310, PA-31-325, PA-31-350 and PA-31P)	3-34
3-34.	Removal of Electronic Trim Amplifier (PA-31-310, PA-31-325, PA-31-350 and PA-31P)	3-34
3-35.	Installation of Electronic Trim Amplifier (PA-31-310, PA-31-325, PA-31-350 and PA-31P)	3-34
3-36.	Installation of Autopilot Amplifier (PA-31-310, PA-31-325, PA-31-350 and PA-31P)	3-35
3-37.	Removal of Attitude Gyro (PA-31-310, PA-31-325, PA-31-350 and PA-31P)	3-35

Paragraph	Page
3-38. Installation of Attitude Gyro (PA-31-310, PA-31-325, PA-31-350 and PA-31P)	3-35
3-39. Removal of Directional Gyro and/or Horizontal Situation Indicator (PA-31-310, PA-31-325, PA-31-350 and PA-31P)	3-36
3-40. Installation of Directional Gyro and/or Horizontal Situation Indicator (PA-31-310, PA-31-325, PA-31-350 and PA-31P)	3-36
3-41. Removal of Altitude Hold Unit (PA-31-310, PA-31-325, PA-31-350 and PA-31P)	3-36
3-42. Installation of Altitude Hold Unit (PA-31-310, PA-31-325, PA-31-350 and PA-31P)	3-37
3-43. Removal of Relay Box (PA-31-310, PA-31-325, PA-31-350 and PA-31P)	3-37
3-44. Installation of Relay Box (PA-31-310, PA-31-325, PA-31-350 and PA-31P)	3-37
3-45. Removal of Roll Servo (PA-31-310, PA-31-325, PA-31-350 and PA-31P)	3-37
3-46. Installation of Roll Servo (PA-31-310, PA-31-325, PA-31-350 and PA-31P)	3-37
3-47. Removal of Pitch Servo (PA-31-310, PA-31-325, PA-31-350 and PA-31P)	3-39
3-48. Installation of Pitch Servo (PA-31-310, PA-31-325, PA-31-350 and PA-31P).....	3-40
3-49. Removal of Rudder Servo (PA-31-310, PA-31-325, PA-31-350 and PA-31P).....	3-40
3-50. Installation of Rudder Servo (PA-31-310, PA-31-325, PA-31-350 and PA-31P)	3-41
3-51. Removal of Pitch Trim Servo (PA-31-310, PA-31-325, PA-31-350 and PA-31P)...	3-42
3-52. Installation of Pitch Trim Servo (PA-31-310, PA-31-325, PA-31-350 and PA-31P)	3-42
3-53. Removal of Yaw Damper Amplifier (PA-31-310, PA-31-325, PA-31-350 and PA-31P)	3-43
3-54. Installation of Yaw Damper Amplifier (PA-31-310, PA-31-325, PA-31-350 and PA-31P)	3-43
3-55. Removal of Gyro Slaving Amplifier (PA-31-310, PA-31-325, PA-31-350 and PA-31P)	3-44
3-56. Installation of Gyro Slaving Amplifier (PA-31-310, PA-31-325, PA-31-350 and PA-31P)	3-44
3-57. Removal of Flux Detector (PA-31-310, PA-31-325, PA-31-350 and PA-31P).....	3-45
3-58. Installation of Flux Detector (PA-31-310, PA-31-325, PA-31-350 and PA-31P)	3-45
3-59. Removal of NAV Converter (IC707) (PA-31-310, PA-31-325, PA-31-350 and PA-31P)	3-45
3-60. Installation of NAV Converter (IC707) (PA-31-310, PA-31-325, PA-31-350 and PA-31P)	3-45
3-61. Removal of Console (PA-32-260, PA-32-300, PA-32R-300, PA-32RT-300 PA-32RT-300T, PA-32-301, PA-32-301T, PA-32R-301 and PA-32R-301T)	3-45
3-62. Installation of Console (PA-32-260, PA-32-300, PA-32R-300, PA-32RT-300, PA-32RT-300T, PA-32-301, PA-32-301T, PA-32R-301 and PA-32R-301T)	3-45
3-63. Removal of Autopilot Amplifier (PA-32-260, S/N 32-750001 to 7700023; PA-32-300, S/N 32-7540001 to 7840045 and PA-32R-300, S/N 32R-7680001 to 7780417).....	3-45
3-64. Removal of Electronic Trim Amplifier (PA-32-260, S/N 32-7500001 to 7700023 and PA-32-300, S/N 32-7540001 to 7840045)	3-46
3-65. Installation of Electronic Trim Amplifier (PA-32-260, S/N 32-7500001 to 7700023 and PA-32-300, S/N 32-7540001 to 7840045)	3-46

Paragraph	Page
3-66. Installation of Autopilot Amplifier (PA-32-260, S/N 32-7500001 to 7700023; PA-32-300, S/N 32-7540001 to 7840045 and PA-32R-300, S/N 32R-7680001 to 7780417)	3-46
3-67. Removal of Autopilot Amplifier (PA-32-260, S/N 32-7800001 and up; PA-32-300, S/N 32-7840046 and up; PA-32R-300, S/N 32R-7780418 and up; PA-32RT-300, PA-32RT-300T, PA-32-301, PA-32-301T, PA-32R-301 and PA-32R-301T)	3-46
3-68. Installation of Autopilot Amplifier (PA-32-260, S/N 32-7800001 and up; PA-32-300, S/N 32-7840046 and up; PA-32R-300, S/N 32R-7780418 and up; PA-32RT-300, PA-32RT-300T, PA-32-301, PA-32-301T, PA-32R-301 and PA-32R-301T)	3-47
3-69. Removal of Electronic Trim Amplifier (PA-32-260, S/N 32-7800001 and up; PA-32-300, S/N 32-7840046 and up; PA-32R-300, PA-32RT-300, PA-32RT-300T, PA-32-301, PA-32-301T, PA-32R-301 and PA-32R-301T)	3-47
3-70. Installation of Electronic Trim Amplifier (PA-32-260, S/N 32-78-00001 and up; PA-32-300, S/N 32-7840046 and up; PA-32R-300, PA-32RT-300, PA-32RT-300T, PA-32-301, PA-32-301T, PA-32R-301 and PA-32R-301T)	3-47
3-71. Removal of Attitude Gyro (PA-32-260, PA-32-300, PA-32R-300, PA-32RT-300, PA-32RT-300T, PA-32-301, PA-32-301T, PA-32R-301 and PA-32R-301T)	3-47
3-72. Installation of Attitude Gyro (PA-32-260, PA-32-300, PA-32R-300, PA-32RT-300, PA-32RT-300T, PA-32-301, PA-32-301T, PA-32R-301 and PA-32R-301T)	3-47
3-73. Removal of Directional Gyro and/or Horizontal Situation Indicator (PA-32-260, PA-32-300, PA-32R-300, PA-32RT-300, PA-32RT-300T, PA-32-301, PA-32-301T, PA-32R-301 and PA-32R-301T)	3-48
3-74. Installation of Directional Gyro and/or Horizontal Situation Indicator (PA-32-260, PA-32-300, PA-32R-300, PA-32RT-300, PA-32RT-300T, PA-32-301, PA-32-301T, PA-32R-301 and PA-32R-301T)	3-48
3-75. Removal of Altitude Hold Unit (PA-32-260, PA-32-300, PA-32R-300, PA-32RT-300, PA-32RT-300T, PA-32-301, PA-32-301T, PA-32R-301 and PA-32R-301T)	3-48
3-76. Installation of Altitude Hold Unit (PA-32-260, PA-32-300, PA-32R-300, PA-32RT-300, PA-32RT-300T, PA-32-301, PA-32-301T, PA-32R-301 and PA-32R-301T)	3-48
3-77. Removal of Relay Box (PA-32-260, S/N 32-7500001 to 7700023; PA-32-300, S/N 32-7540001 to 7840045 and PA-32R-300, S/N 32R-7680001 to 7780417)	3-48
3-78. Installation of Relay Box (PA-32-260, S/N 32-7500001 to 7700023; PA-32-300, S/N 32-7540001 to 7840045 and PA-32R-300, S/N 32R-7680001 to 7780417)	3-49
3-79. Removal of Relay Box (PA-32-260, S/N 32-7800001 and up; PA-32-300, S/N 32-7840046 and up; PA-32R-300, S/N 32R-7780418 and up; PA-32RT-300, PA-32RT-300T, PA-32-301, PA-32-301T, PA-32R-301 and PA-32R-301T)	3-49

Paragraph	Page
3-80. Installation of Relay Box (PA-32-260, S/N 32-7800001 and up; PA-32-300, S/N 32-7840046 and up; PA-32R-300, S/N 32R-7780418 and up; PA-32RT-300, PA-32RT-300T, PA-32-301, PA-32-301T, PA-32R-301 and PA-32R-301T)	3-49
3-81. Removal of Roll Servo (PA-32-260, PA-32-300, PA-32R-300, PA-32RT-300, PA-32RT-300T, PA-32-301, PA-32-301T, PA-32R-301 and PA-32R-301T)	3-49
3-82. Installation of Roll Servo (PA-32-260, PA-32-300, PA-32R-300, PA-32-RT-300, PA-32RT-300T, PA-32-301, PA-32-301T, PA-32R-301 and PA-32R-301T)	3-49
3-83. Removal of Pitch Servo (PA-32-260 and PA-32-300, S/N 32-7540001 to 7840222)	3-52
3-84. Removal of Pitch Servo (PA-32-300, S/N 32-7940001 and up; PA-32R-300, PA-32RT-300, PA-32RT-300T, PA-32-301, PA-32-301T, PA-32R-301 and PA-32R-301T)	3-52
3-85. Installation of Pitch Servo (PA-32-260 and PA-32-300, S/N 32-7540001 to 7840222)	3-52
3-86. Installation of Pitch Servo (PA-32-300, S/N 32-7940001 and up; PA-32R-300, PA-32RT-300, PA-32RT-300T, PA-32-301, PA-32-301T, PA-32R-301 and PA-32R-301T)	3-53
3-87. Removal of Pitch Trim Servo (PA-32-260, PA-32-300, PA-32R-300, PA-32RT-300, PA-32RT-300T, PA-32-301, PA-32-301T, PA-32R-301 and PA-32R-301T)	3-55
3-88. Installation of Pitch Trim Servo (PA-32-260, PA-32-300, PA-32R-300, PA-32RT-300, PA-32RT-300T, PA-32-301, PA-32-301T PA-32R-301 and PA-32R-301T)	3-55
3-89. Deleted	
3-90. Deleted	
3-91. Deleted	
3-92. Deleted	
3-93. Deleted	
3-94. Deleted	
3-95. Removal of Console (PA-34-200T)	3-57
3-96. Installation of Console (PA-34-200T)	3-57
3-97. Removal of Autopilot Amplifier (PA-34-200T)	3-57
3-98. Installation of Autopilot Amplifier (PA-34-200T)	3-59
3-99. Removal of Electronic Trim Amplifier (PA-34-200T)	3-59
3-100. Installation of Electronic Trim Amplifier (PA-34-200T)	3-59
3-101. Removal of Attitude Gyro (PA-34-200T)	3-59
3-102. Installation of Attitude Gyro (PA-34-200T)	3-59
3-103. Removal of Directional Gyro and/or Horizontal Situation Indicator (PA-34-200T)	3-59
3-104. Installation of Directional Gyro and/or Horizontal Situation Indicator (PA-34-200T)	3-60
3-105. Removal of Altitude Hold Unit (PA-34-200T, Serial Nos. 34-7570001 to 34-7770185 incl., 34-7770187 to 34-7770263 incl.)	3-60
3-106. Installation of Altitude Hold Unit (PA-34-200T, Serial Nos. 34-7570001 to 34-7770185 incl., 34-7770187 to 34-7770263 incl.)	3-60
3-107. Removal of Altitude Hold Unit (PA-34-200T, Serial Nos. 34-7770186, 34-7770264 and up)	3-60

Paragraph	Page
3-108. Installation of Altitude Hold Unit (PA-34-200T, Serial Nos. 34-7770186, 34-7770264 and up)	3-60
3-109. Removal of Relay Box (PA-34-200T)	3-61
3-110. Installation of Relay Box (PA-34-200T)	3-61
3-111. Removal of Roll Servo (PA-34-200T)	3-61
3-112. Installation of Roll Servo (PA-34-200T)	3-63
3-113. Removal of Pitch Servo (PA-34-200T)	3-64
3-114. Installation of Pitch Servo (PA-34-200T)	3-64
3-115. Removal of Pitch Trim Servo (PA-34-200T)	3-65
3-116. Installation of Pitch Trim Servo (PA-34-200T)	3-66
3-117. Removal of Gyro Slaving Amplifier (PA-34-200T)	3-67
3-118. Installation of Gyro Slaving Amplifier (PA-34-200T)	3-67
3-119. Removal of Flux Detector (PA-34-200T)	3-67
3-120. Installation of Flux Detector (PA-34-200T)	3-67
3-121. Deleted	
3-122. Deleted	
3-123. Removal of Console (PA-44-180)	3-68
3-124. Installation of Console (PA-44-180)	3-68
3-125. Removal of Autopilot Amplifier (PA-44-180)	3-68
3-126. Installation of Autopilot Amplifier (PA-44-180)	3-68
3-127. Removal of Electronic Trim Amplifier (PA-44-180)	3-68
3-128. Installation of Electronic Trim Amplifier (PA-44-180)	3-68
3-129. Removal of Attitude Gyro (PA-44-180)	3-69
3-130. Installation of Attitude Gyro (PA-44-180)	3-69
3-131. Removal of Directional Gyro and/or Horizontal Situation Indicator	3-69
3-132. Installation of Directional Gyro and/or Horizontal Situation Indicator (PA-44-180)	3-69
3-133. Removal of Altitude Hold Unit (PA-44-180)	3-69
3-134. Installation of Altitude Hold Unit (PA-44-180)	3-70
3-135. Removal of Relay Box (PA-44-180)	3-70
3-136. Installation of Relay Box (PA-44-180)	3-70
3-137. Removal of Roll Servo (PA-44-180)	3-71
3-138. Installation of Roll Servo (PA-44-180)	3-71
3-139. Removal of Pitch Servo (PA-44-180)	3-72
3-140. Installation of Pitch Servo (PA-44-180)	3-72
3-141. Removal of Pitch Trim Servo (PA-44-180)	3-73
3-142. Installation of Pitch Trim Servo (PA-44-180)	3-74
3-143. Removal of Console (PA-28RT-201 and PA-28RT-201T)	3-74
3-144. Installation of Console (PA-28RT-201 and PA-28RT-201T)	3-74
3-145. Removal of Autopilot Amplifier (PA-28RT-201 and PA-28RT-201T)	3-74
3-146. Removal of Electronic Trim Amplifier (PA-28RT-201 and PA-28RT-201T)	3-75
3-147. Installation of Electronic Trim Amplifier (PA-28RT-201 and PA-28RT-201T)	3-75
3-148. Installation of Autopilot Amplifier (PA-28RT-201 and PA-28RT-201T)	3-75
3-149. Removal of Attitude Gyro (PA-28RT-201 and PA-28RT-201T)	3-75
3-150. Installation of Attitude Gyro (PA-28RT-201 and PA-28RT-201T)	3-75

Paragraph	Page
3-151. Removal of Directional Gyro and/or Horizontal Situation Indicator (PA-28RT-201 and PA-28RT-201T)	3-75
3-152. Installation of Directional Gyro and/or Horizontal Situation Indicator (PA-28RT-201 and PA-28RT-201T)	3-76
3-153. Removal of Altitude Hold Unit (PA-28RT-201 and PA-28RT-201T)	3-76
3-154. Installation of Altitude Hold Unit (PA-28RT-201 and PA-28RT-201T)	3-76
3-155. Removal of Relay Box (PA-28RT-201 and PA-28RT-201T)	3-76
3-156. Installation of Relay Box (PA-28RT-201 and PA-28RT-201T)	3-76
3-157. Removal of Roll Servo (PA-28RT-201 and PA-28RT-201T)	3-76
3-158. Installation of Roll Servo (PA-28RT-201 and PA-RT-201T)	3-77
3-159. Removal of Pitch Servo (PA-28RT-201 and PA-28RT-201T)	3-77
3-160. Installation of Pitch Servo (PA-28RT-201 and PA-28RT-201T)	3-77
3-161. Removal of Pitch Trim Servo (PA-28RT-201 and PA-28RT-201T)	3-78
3-162. Installation of Pitch Trim Servo (PA-28RT-201 and PA-28RT-201T)	3-79
3-163. Removal of Nav Flag Adapter (PA-23-250 Six Place, S/N 27-7554001, 7554074 to 7754127; PA-31, S/N 31-7512023 to 7712064; PA-31-350, S/N 31-7552054 to 7752100, 31-7752102 to 7752113 and PA-31P, S/N 31P-7630014 to 7730012)	3-79
3-164. Installation of Nav Flag Adapter (PA-23-250 Six Place, S/N 27-7554001, 7554074 to 7754127; PA-31, S/N 31-7512023 to 7712064; PA-31-350, S/N 31-7552054 to 7752100, 31-7752102 to 7752113 and PA-31P, S/N 31P-7630014 to 7730012)	3-79
3-165. Removal of Nav Flag Adapter (PA-32-260, S/N 32-7600001 to 7700017; PA-32-300, S/N 32-7640001 to 7740075; PA-32R-300, S/N 32R-7680001 to 7780350 and PA-34-200T, S/N 34-7670001 to 7770261) ..	3-79
3-166. Installation of Nav Flag Adapter (PA-32-260, S/N 32-7600001 to 7700017; PA-32-300, S/N 32-7640001 to 7740075; PA-32R-300, S/N 32R-7680001 to 7780350 and PA-34-200T, S/N 34-7670001 to 7770261)	3-80
3-167. Removal of KA-52 Autopilot Adapter	3-80
3-168. Installation of KA-52 Autopilot Adapter	3-81

SECTION III

REMOVAL AND INSTALLATION

3-1. INTRODUCTION. The instructions in this section provide removal and installation procedures for the AltiMatic IIC components. Checks and adjustments are limited to those required for removal and installation of the components. Repairs, Bench Checks and Adjustments, and Set-Up Procedures are found in the sections to follow.

On the following pages are two tables. Table III-I lists all the Pitch Trim Servos installed in each airplane. Table III-II lists all the components of the AltiMatic IIC installed in each airplane.

Figure 3-1 is used to properly set up and check a servo prior to installation in the airplane. The use of this illustration will be discussed in Paragraph 3-2.

To help initially locate the AltiMatic IIC component parts in any given airplane, refer to Figures 3-3 thru 3-7a inclusive. The Radio Coupler, which is optional equipment, is not shown in these illustrations. When the coupler is installed, it is easily located in the instrument panel.

When installing a servo bridle cable, reference is made to either Figure 3-8 or Figure 3-9. The illustrated airplane cable systems shown in these illustrations will help to properly adjust the bridle cable tension.

CAUTION

The Allen head set screw (Piper P/N 757 579) used in the servo capstan may have a nylon insert on the shank. The insert is used as a locking device and any screw with this on should be discarded after it has been removed because the locking capability of the nylon is limited to one installation.

3-2. PRE-INSTALLATION CHECK AND ADJUSTMENTS OF ROLL, YAW AND PITCH SERVO ASSEMBLIES. Prior to installation of a roll, yaw or pitch servo assembly, certain checks and adjustments should be conducted according to Figure 3-1 and the following instructions.

NOTE

Figure 3-1 describes the set-up procedures for the 1C363-1, 1C465-1, 1C470-1 and 1C508-1 Servos.

a. Switch Position: Check the position of either the switch plate or the motor wiring to pin C and pin D of the servo connector with the appropriate table in Figure 3-1. To set the switch in the correct position, remove the two screws through the face of the switch plate. Move the slide switch to the left or right, as necessary, and reinstall the plate with the corresponding letter visible. If the servo does not feature a switch, the wiring from the motor to pin C and pin D of the servo motor connector must be checked. For clockwise rotation of the shaft, place the Blk wire on pin C and the Red wire on pin D. For counterclockwise rotation, place the Red wire on pin C and the Blk wire on pin D.

b. Cable Guards: Check the correct location and number of guards required for each servo. REMOVE ALL OTHER CABLE GUARDS FROM THE SERVO.

c. Torque Output Clutch Adjustment: The Clutch Adjustment Procedure is not authorized in the field at this time on copper/carbon type clutches as per manufacturer EDO-AIRE Mitchell.

d. Servo Model Number: Three digits will identify the servo as to the model of the servo as installed in the airplane. Whether it is set for a roll, yaw or pitch servo will be identified by the letter placed after the three digits, either "R", "Y" or "P".

e. Bridle Cable Tension: The tension of the airplane control cables should be checked to assure that it is in accordance with the specifications for the particular model before attachment of the bridle cable is accomplished.

TABLE III-I. ALTIMATIC IIC TRIM SERVO CLUTCH TENSION

AIRPLANE	SERVO NO.	SWITCH POSITION	CLUTCH SETTING
PA-23-250	1C469-6-504	L	25 ± 5 lbs.
PA-28RT-201;-201T	1C373-6-755	R	21 ± 4 lbs.
PA-31-310	1C469-6-483	R	20 ± 5 lbs.
PA-31-325	1C469-6-483	R	20 ± 5 lbs.
PA-31-350	1C469-6-498	R	25 ± 3 lbs.
PA-31P	1C469-6-484	R	35 ± 5 lbs.
PA-32-260/300	SEE NOTE 1C373-6-488	R	18 ± 3 lbs.
PA-32R-300&			
PA-32RT-300/300T	SEE NOTE 1C373-6-529	L	18 ± 3 lbs.
PA-32-301;-301T	1C373-6-529	L	18 ± 3 lbs.
PA-32R-301-301T	1C373-6-677	L	21 ± 4 lbs.
PA-34-200T	1C373-6-487	L	20 ± 5 lbs.
PA-44-180	1C373-6-719	L	21 ± 4 lbs.
PA-44-180T	1C373-6-719	L	21 ± 4 lbs.

NOTE

1C373-6-529 Trim Servo and 1C508-1-775P Pitch Servo used on PA-32-300 on S/N PA-32-7940001 and up; 1C373-6-677 Trim Servo (clutch setting 21 ± 4 lbs.) used on PA-32RT-300/300T on S/N PA-32R-7985014 and up and PA-32R-7887004, 7887051 and up.

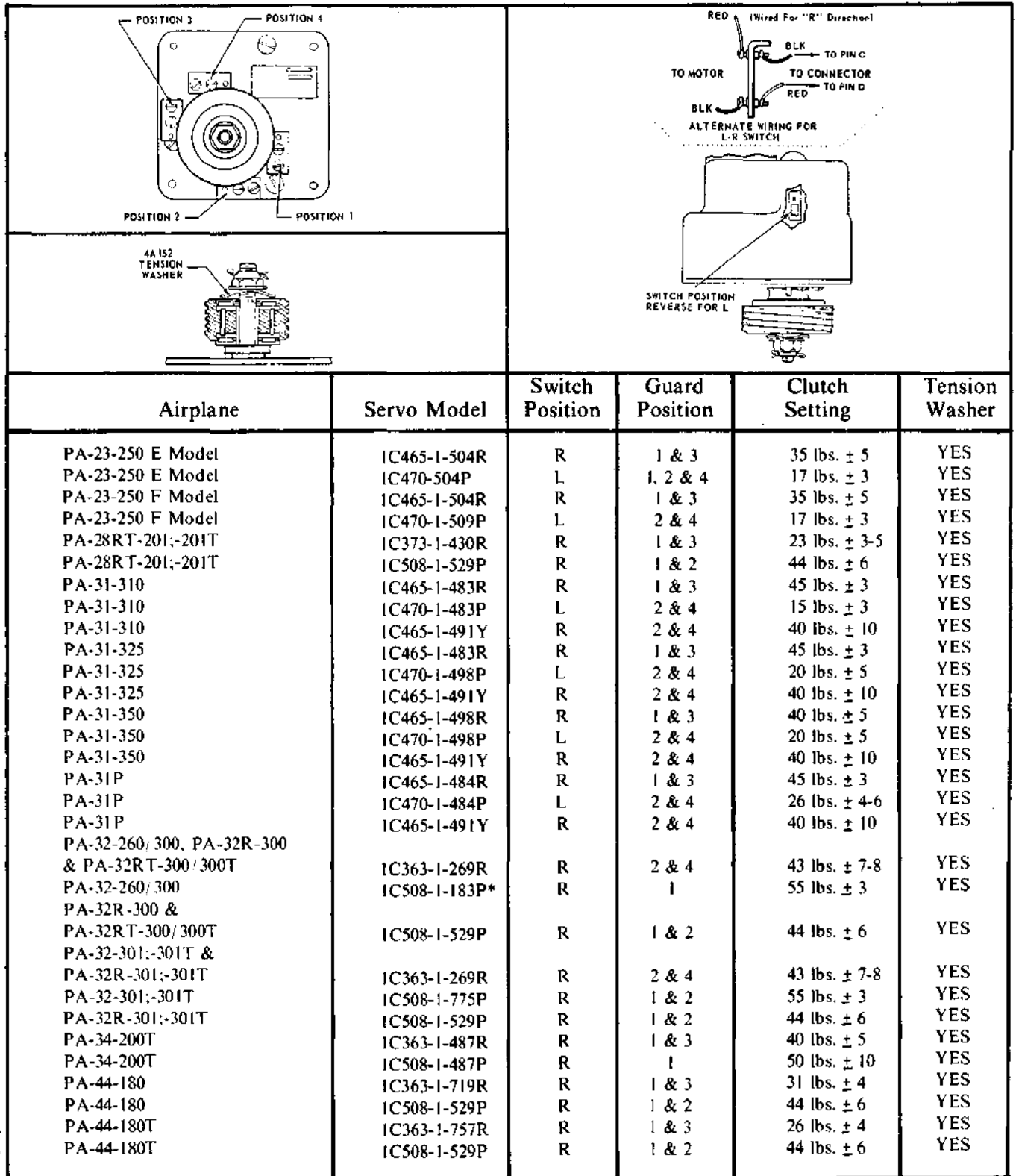

*SEE NOTE
PAGE 3-2

Figure 3-1. Roll, Rudder and Pitch Servo Guide

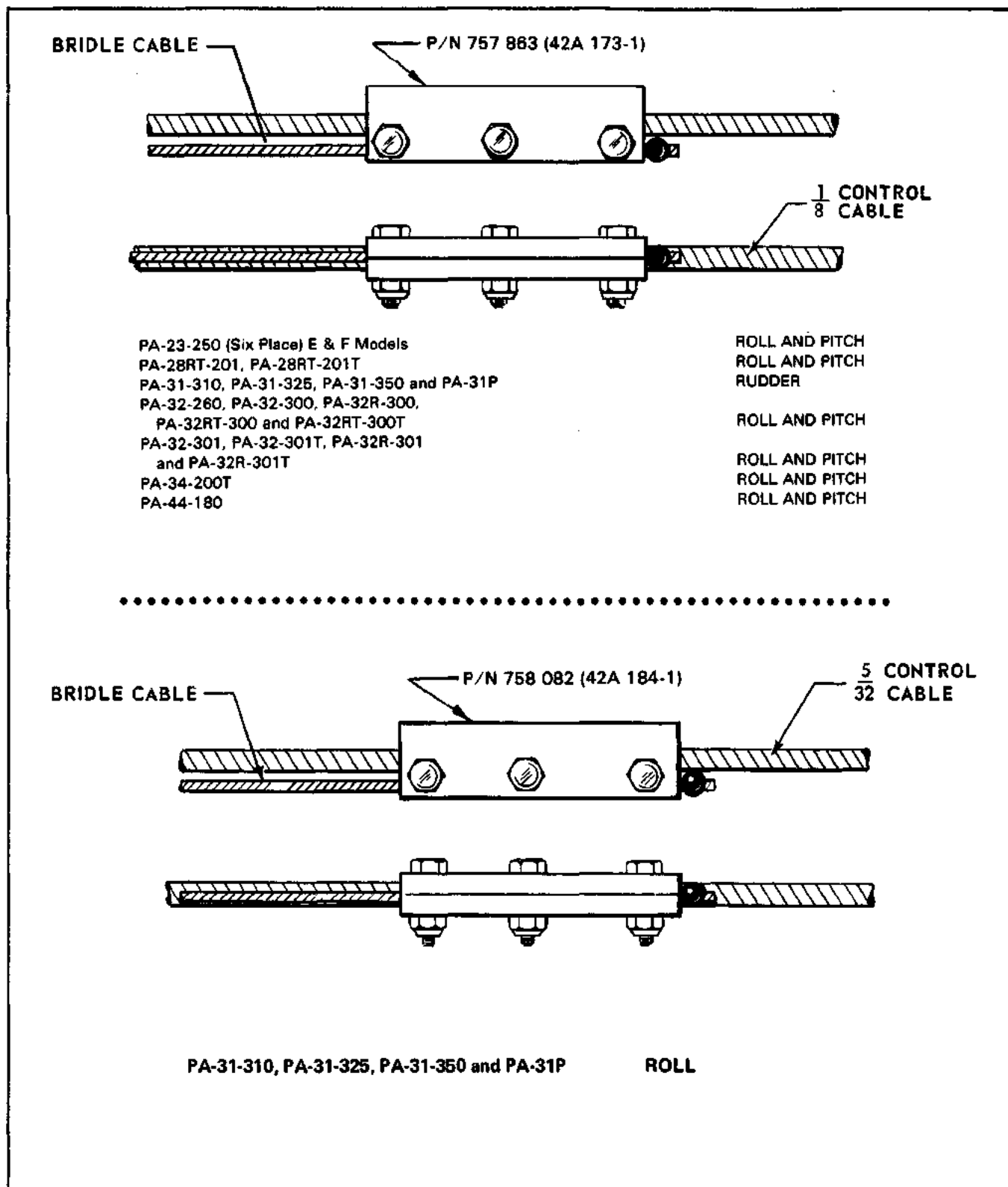

Figure 3-2. Bridle Cable Clamp Installation

TABLE III-II.

AIRPLANE	CONSOLE	AMPLIFIER	PITCH SERVO	ROLL SERVO	RUDDER SERVO	ATTITUDE HOLD UNIT	RADIO COUPLER (OPT.)	REMARKS
PA-23-250 E Model F Model	ID720 ID720 ID720	IC515-1 IC515-1 IC515-1	IC470-1-504P IC470-1-504P IC508-1-529P	IC465-1-504R IC465-1-504R IC303-1-430R		IC407 IC407 IC725	IC388* (Any Modification) IC388	*Aurplane equipped with VOA-40/50 series Omni-loc converters must have Radio Coupler Piper P/N 757 898 installed.
PA-28R-1-201L-201T								
PA-11-310 PA-11-325	ID720 ID720	IC515-1 IC515-1	IC470-1-483P IC470-1-498P	IC465-1-483R IC465-1-483R	IC465-1-491Y IC465-1-491Y	IC407 IC407	IC388* (Any Modification)	
PA-31-350	ID720	IC515-1	IC470-1-498P	IC465-1-498R	IC465-1-491Y	IC407	IC388* (Any Modification)	
PA-11P	ID720	IC515-1	IC470-1-484P	IC465-1-484R	IC465-1-491Y	IC407	IC388* (Any Modification)	
PA-12-260 PA-12-300	ID720 ID720	IC515-1 IC515-1	IC508-1-183P IC508-1-181P or IC508-1-775P	IC303-1-269R IC303-1-269R IC303-1-269R		IC725 or IC725 IC725	IC388* (Any Modification) IC388	IC725 Attitude Hold Unit used on PA-12-260 with S/N 12 7004001 and up and on PA-12-300 with S/N 32 7840016 and up.
PA-12-301-301T								
PA-33R-300 PA-32R-301-301T PA-32R-300 PA-32R-1-300T	ID720 ID720 ID720 ID720	IC515-1 IC515-1 IC515-1 IC515-1	IC508-1-529P IC508-1-529P IC508-1-529P IC508-1-529P	IC303-1-269R IC303-1-269R IC303-1-269R IC303-1-269R		IC725 IC725 IC725 IC725	IC388* (Any Modification) IC388* (Any Modification)	IC725 Attitude Hold Unit used on PA-32-260 with S/N 32 7800001 and up and on PA-32-300 with S/N 32 7940006 and up.
PA-34-2001	ID720	IC515-3	IC508-1-487P	IC303-1-487R		IC407 or IC725	IC388* (Any Modification)	IC725 Attitude Hold Unit used on PA-34-200T with S/N 34-7770186-34-7770264 and up.
PA-44-180	ID720	IC515-1	IC508-1-529P	IC303-1-719R		IC725	IC388* (Any Modification)	
PA-44-1801	ID720	IC515-1	IC508-1-529P	IC303-1-757R		IC725	IC388* (Any Modification)	S/N 44-8107001 & up S/N 44-7995001 & up

ALTIMATIC IIC APPLICABILITY CHART

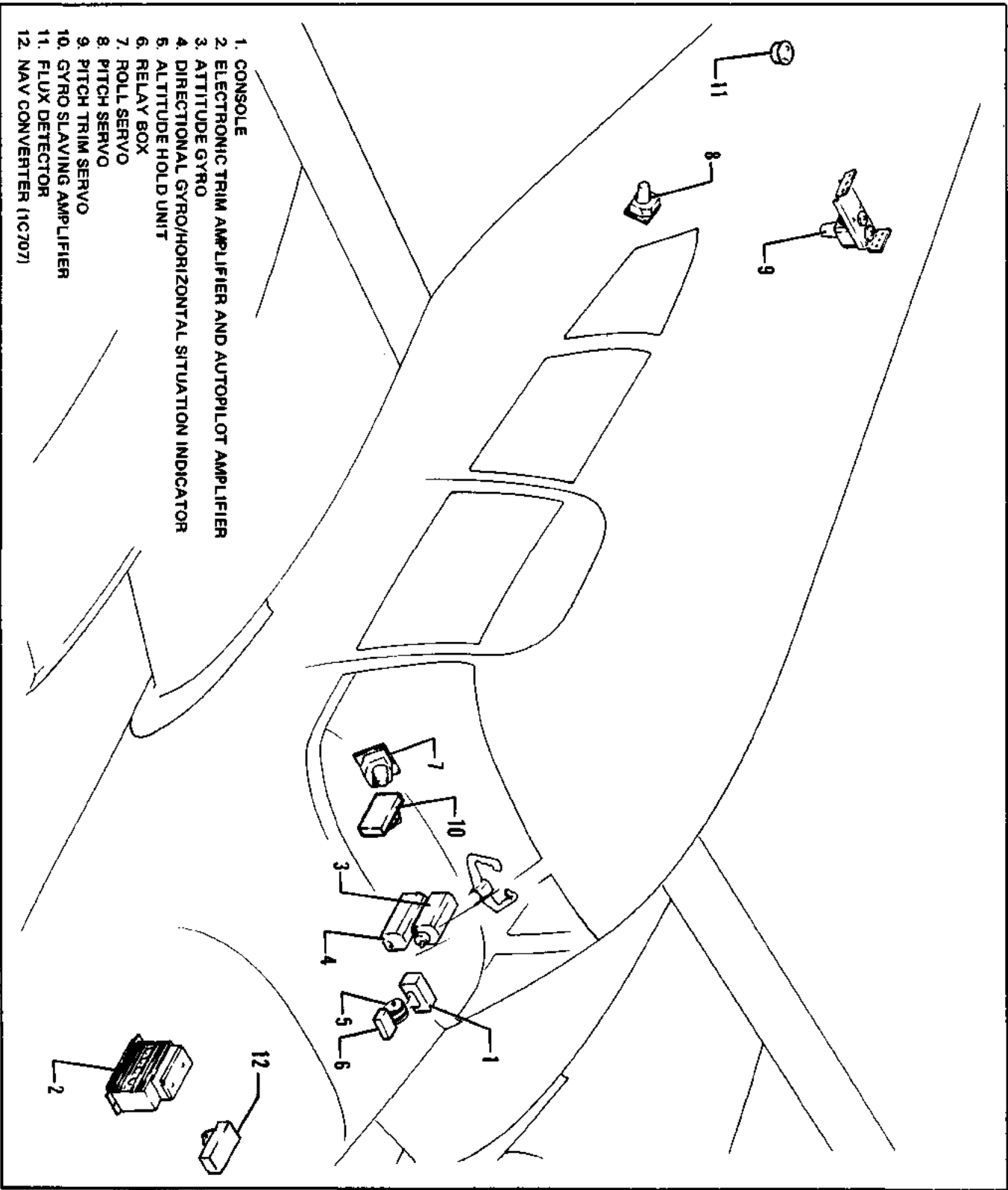

Figure 3-3. PA-23-250 (Six Place) E & F Model's AltMatic IIC Layout

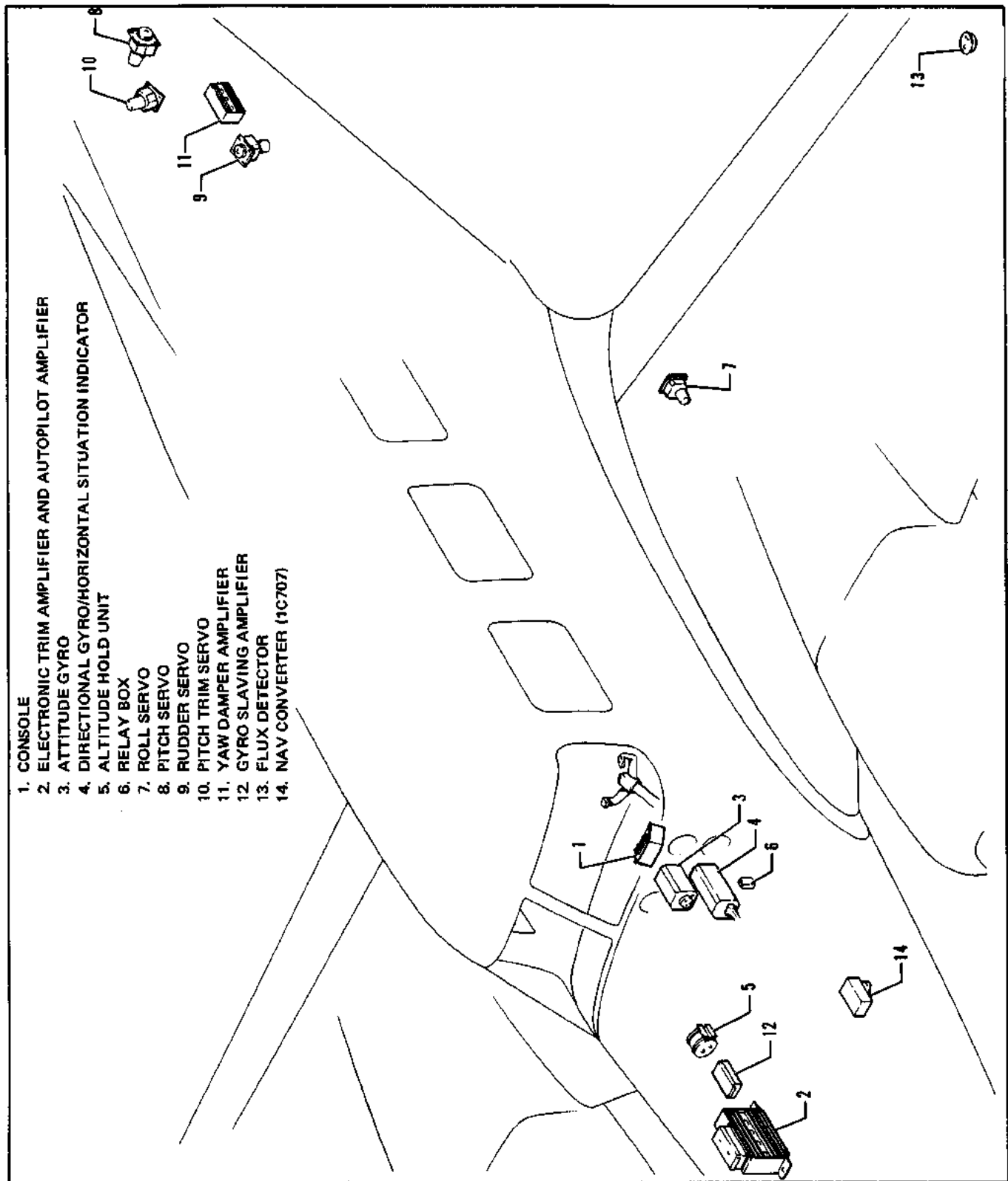
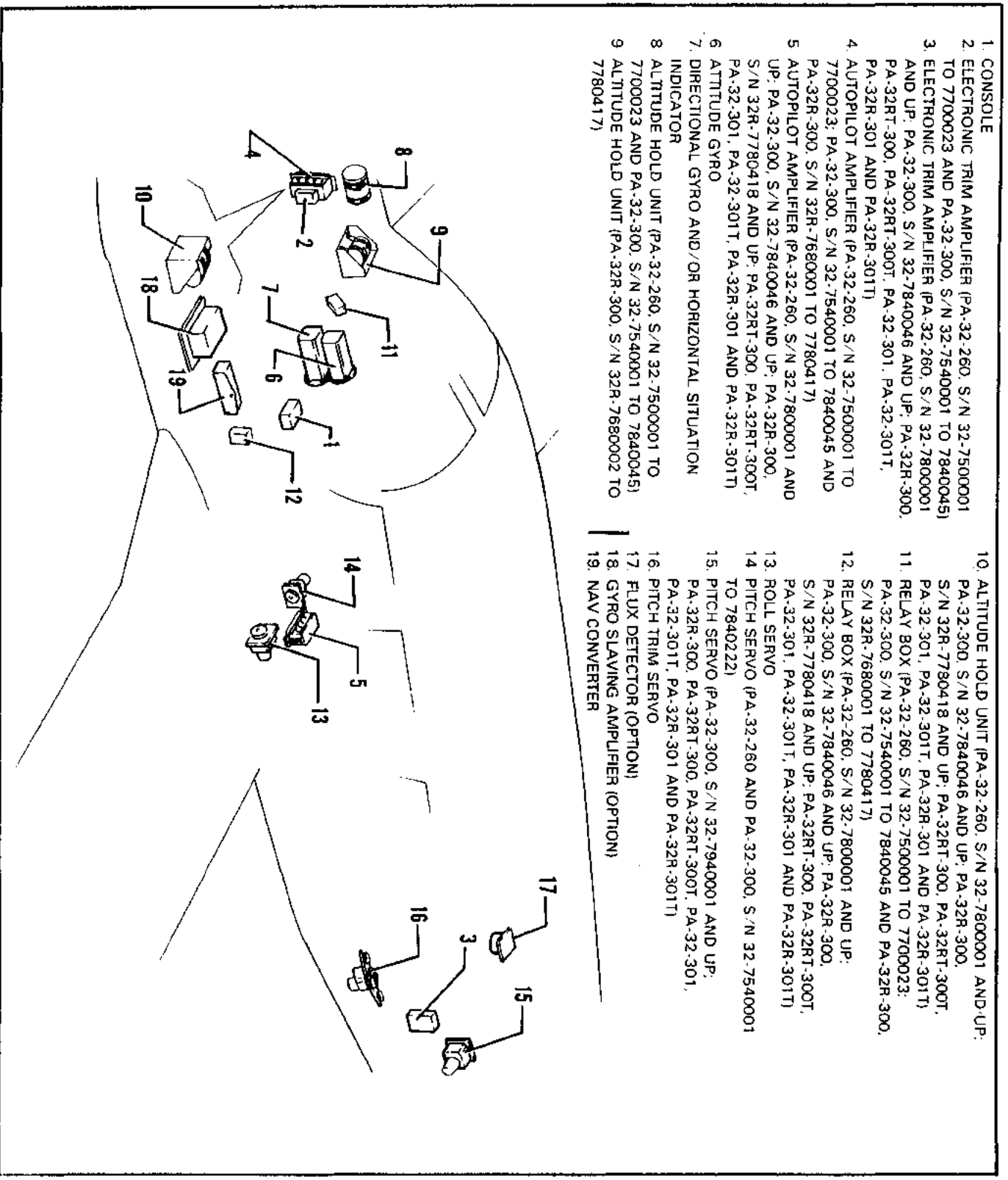

Figure 3-4. PA-31-310, PA-31-325, PA-31-350 and PA-31P AltiMatic IIC Layout

Figure 3-5. PA-32-260, PA-32-300, PA-32R-300, PA-32RT-300, PA-32RT-300T, PA-32-301, PA-32-301T, PA-32R-301 & PA-32R-301T Altimatec III C Layout



1. CONSOLE
2. ELECTRONIC TRIM AMPLIFIER (PA-32-260, S/N 32-7500001 TO 7700023 AND PA-32-300, S/N 32-7540001 TO 7840045)
3. ELECTRONIC TRIM AMPLIFIER (PA-32-260, S/N 32-7800001 AND UP; PA-32-300, S/N 32-7840046 AND UP; PA-32R-300, PA-32RT-300, PA-32RT-300T, PA-32-301, PA-32-301T, PA-32R-301 AND PA-32R-301T)
4. AUTOPILOT AMPLIFIER (PA-32-260, S/N 32-7500001 TO 7700023; PA-32-300, S/N 32-7540001 TO 7840045 AND PA-32R-300, S/N 32R-7680001 TO 7780417)
5. AUTOPILOT AMPLIFIER (PA-32-260, S/N 32-7800001 AND UP; PA-32-300, S/N 32R-7780418 AND UP; PA-32RT-300, PA-32RT-300T, PA-32-301, PA-32-301T, PA-32R-301 AND PA-32R-301T)
6. ATTITUDE GYRO
7. DIRECTIONAL GYRO AND/OR HORIZONTAL SITUATION INDICATOR
8. ALTITUDE HOLD UNIT (PA-32-260, S/N 32-7500001 TO 7700023 AND PA-32-300, S/N 32-7540001 TO 7840045)
9. ALTITUDE HOLD UNIT (PA-32R-300, S/N 32R-7680002 TO 7780417)
10. ALTITUDE HOLD UNIT (PA-32-260, S/N 32-7800001 AND UP; PA-32-300, S/N 32-7840046 AND UP; PA-32R-300, S/N 32R-7780418 AND UP; PA-32RT-300, PA-32RT-300T, PA-32-301, PA-32-301T, PA-32R-301 AND PA-32R-301T)
11. RELAY BOX (PA-32-260, S/N 32-7500001 TO 7700023; PA-32-300, S/N 32-7540001 TO 7840045 AND PA-32R-300, S/N 32R-7680001 TO 7780417)
12. RELAY BOX (PA-32-260, S/N 32-7800001 AND UP; PA-32-300, S/N 32-7840046 AND UP; PA-32R-300, S/N 32R-7780418 AND UP; PA-32RT-300, PA-32RT-300T, PA-32-301, PA-32-301T, PA-32R-301 AND PA-32R-301T)
13. ROLL SERVO
14. PITCH SERVO (PA-32-260 AND PA-32-300, S/N 32-7540001 TO 7840222)
15. PITCH SERVO (PA-32-300, S/N 32-7940001 AND UP; PA-32R-300, PA-32RT-300, PA-32RT-300T, PA-32-301, PA-32-301T, PA-32R-301 AND PA-32R-301T)
16. PITCH TRIM SERVO
17. FLUX DETECTOR (OPTION)
18. GYRO SLAVING AMPLIFIER (OPTION)
19. NAV CONVERTER

Figure 3-6. PA-34-200T AltiMatic IIC Layout

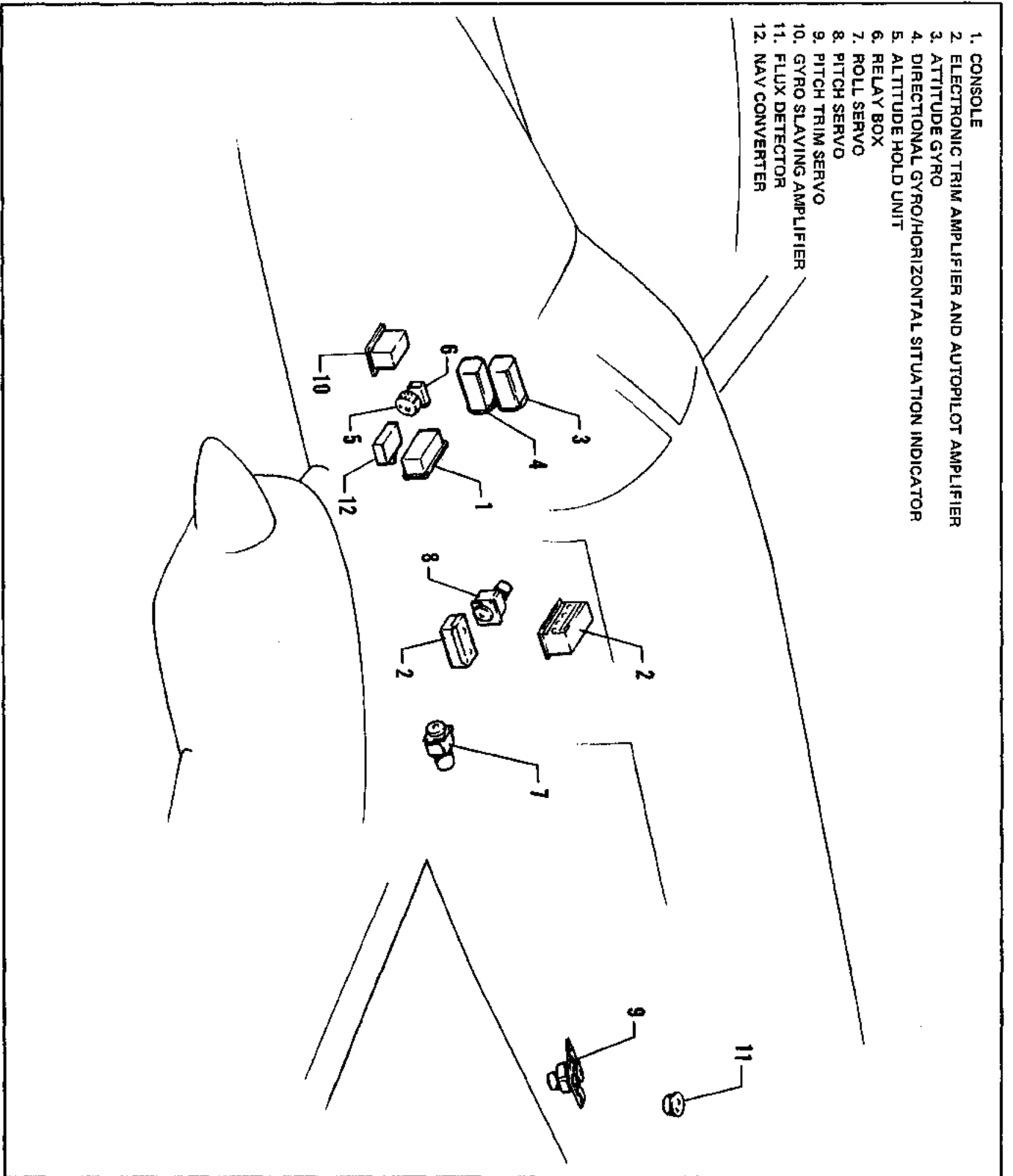

- 1. CONSOLE
- 2. ELECTRONIC TRIM AMPLIFIER AND AUTOPILOT AMPLIFIER
- 3. ATTITUDE GYRO
- 4. DIRECTIONAL GYRO/HORIZONTAL SITUATION INDICATOR
- 5. ALTITUDE HOLD UNIT
- 6. RELAY BOX
- 7. ROLL SERVO
- 8. PITCH SERVO
- 9. GYRO SLAVING SERVO
- 10. GYRO SLAVING AMPLIFIER
- 11. FLUX DETECTOR
- 12. NAV CONVERTER

Figure 3-7. PA-44-180 AltMatic III C Layout

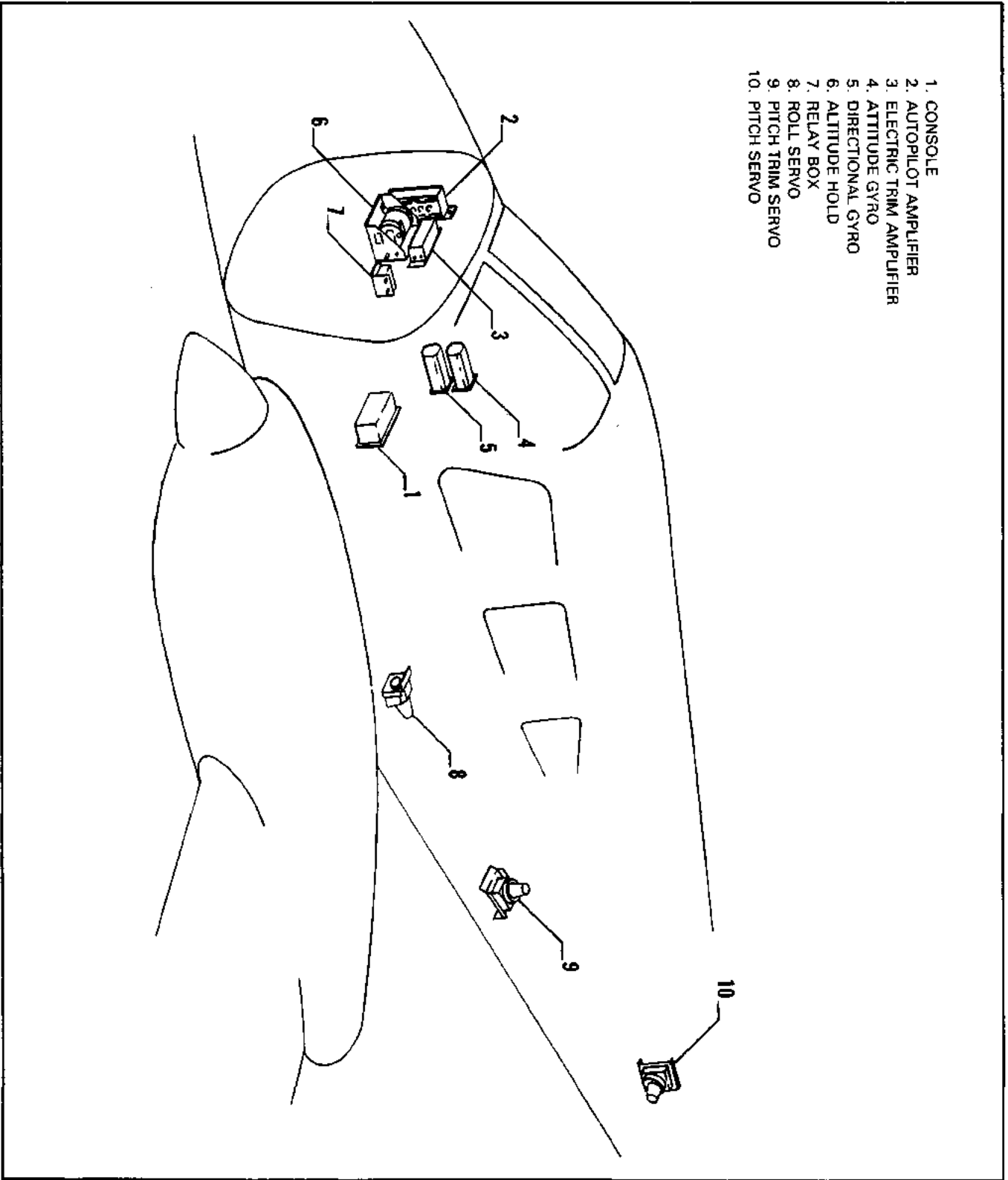

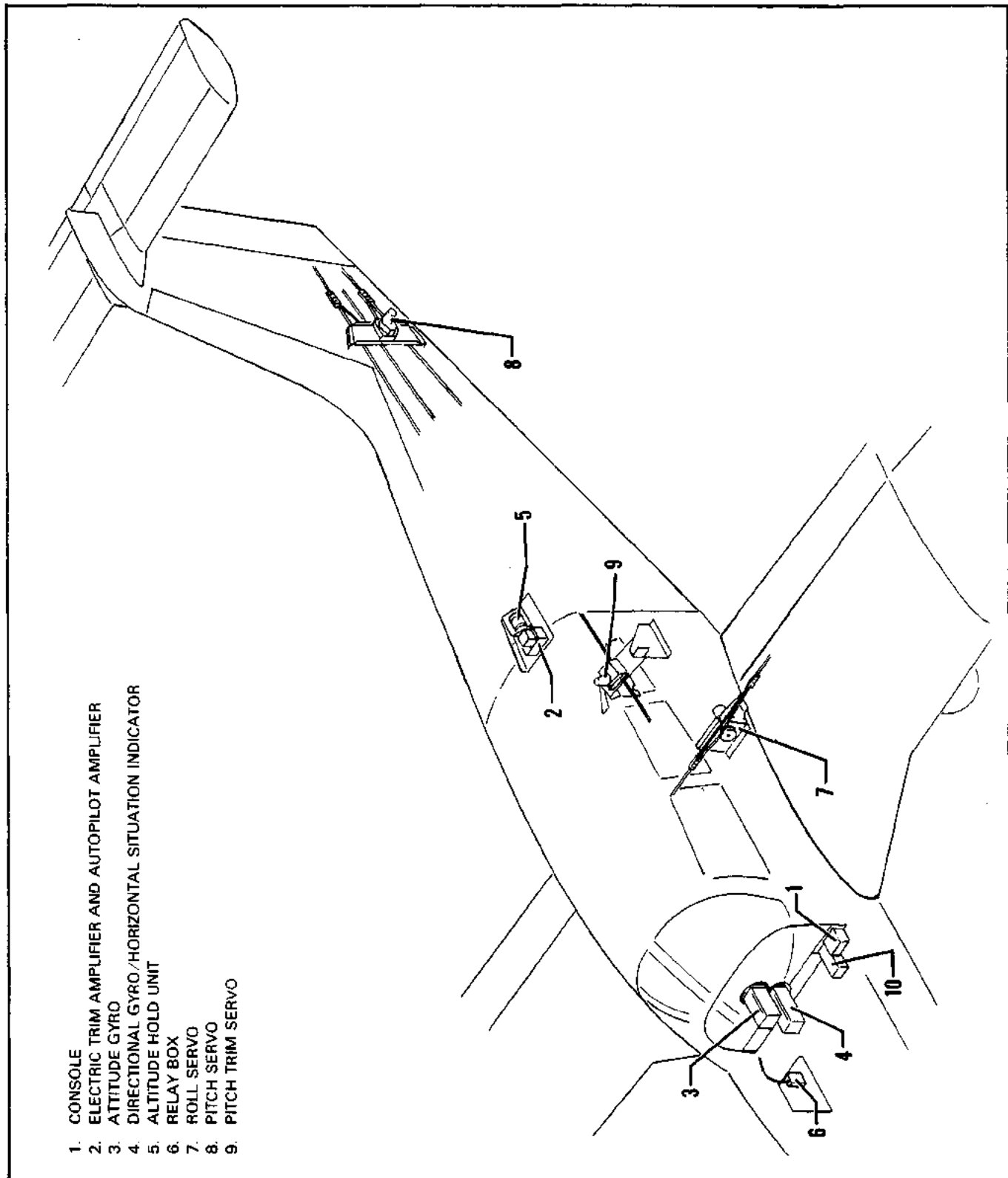

Figure 3-7a. PA-28RT-201 and PA-28RT-201T AltiMatic IIC Layout

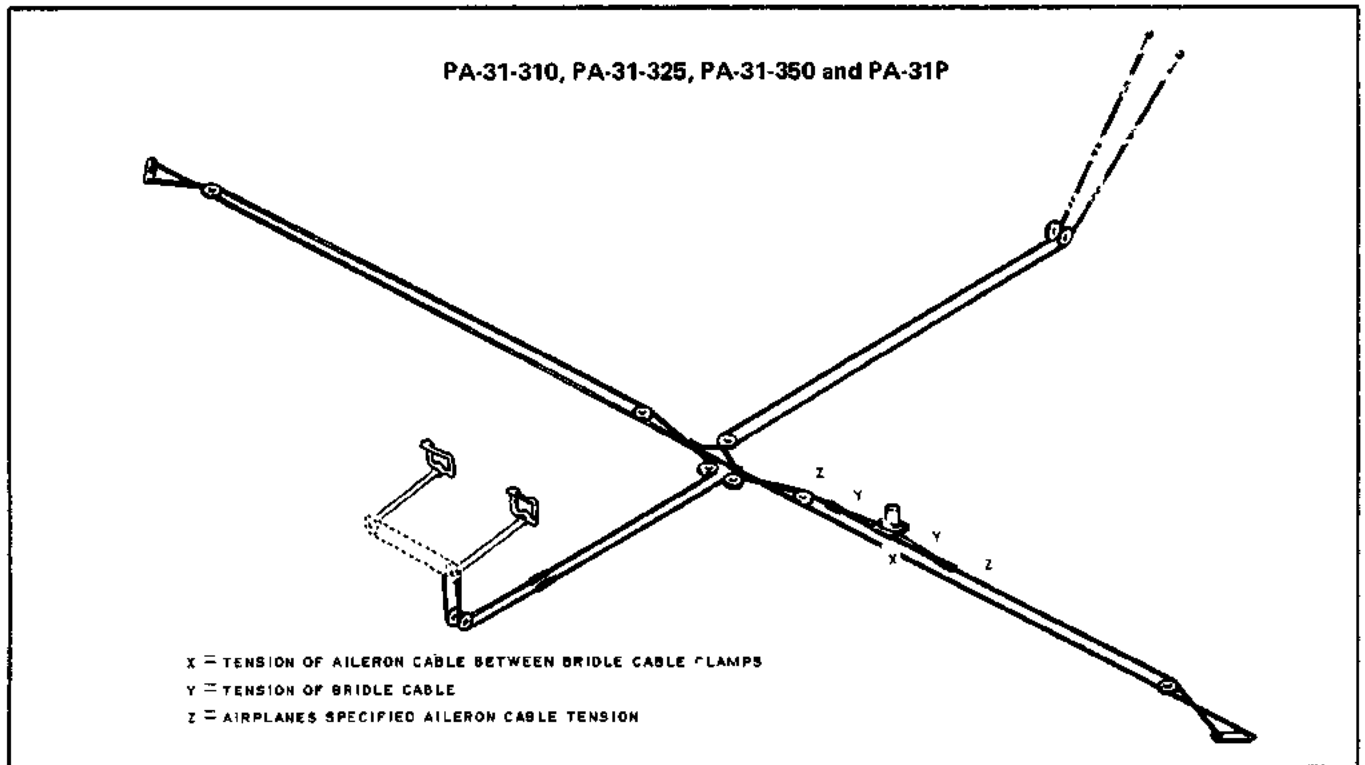
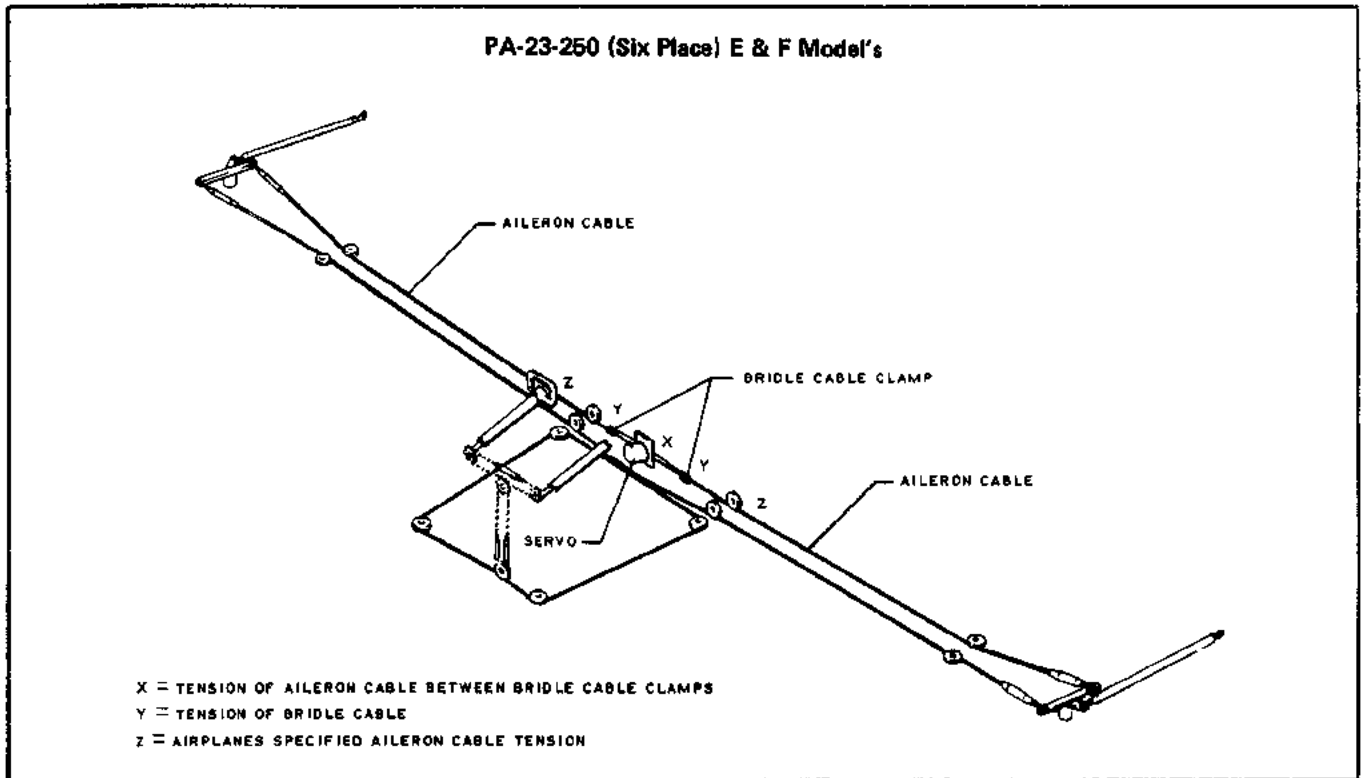

Figure 3-8. Roll Servo Cable Tension Diagram

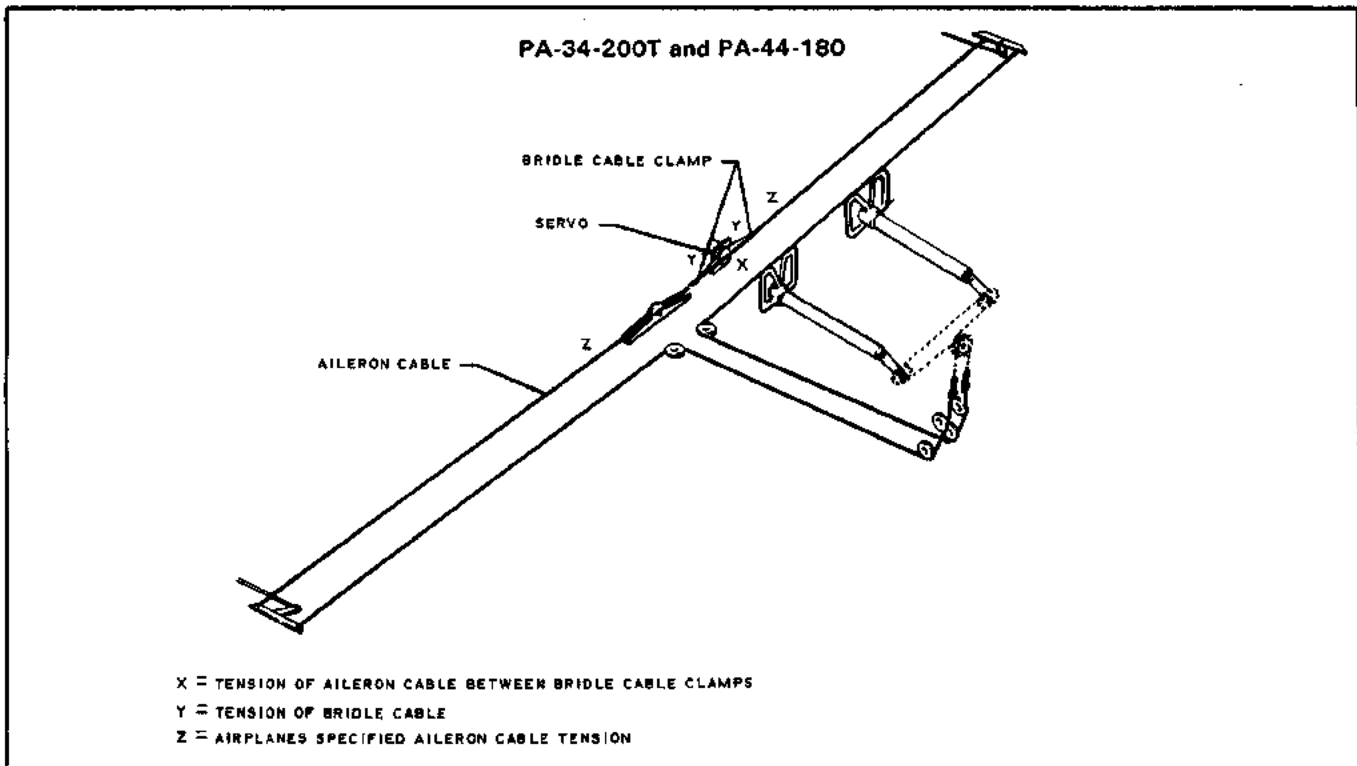
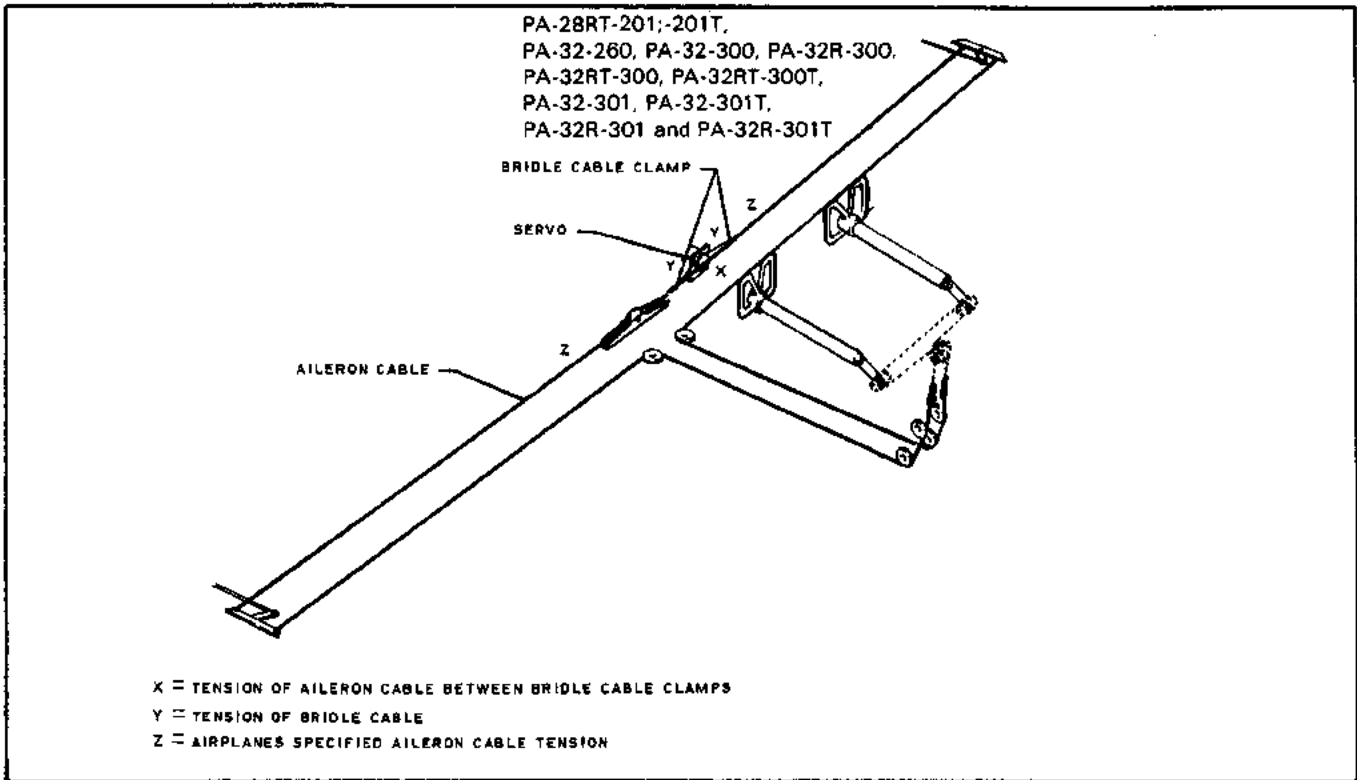

Figure 3-8. Roll Servo Cable Tension Diagram (cont.)

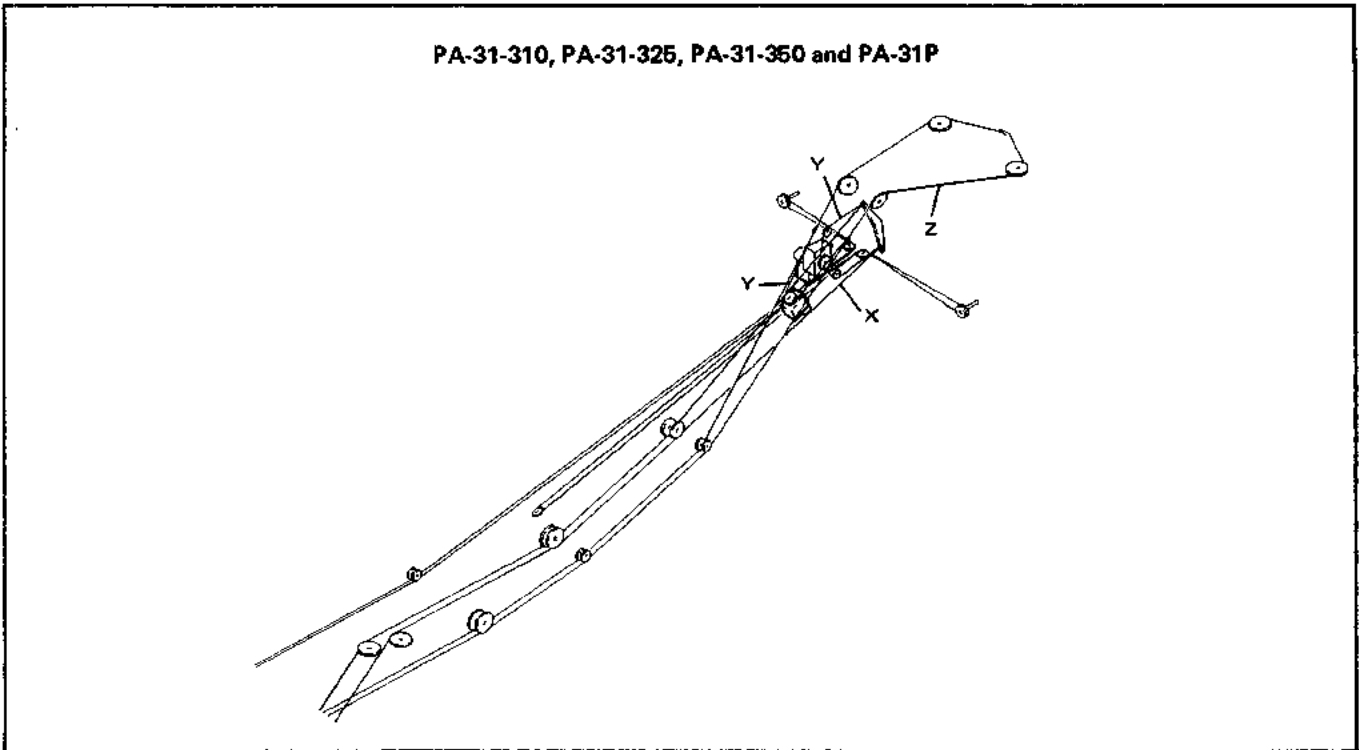
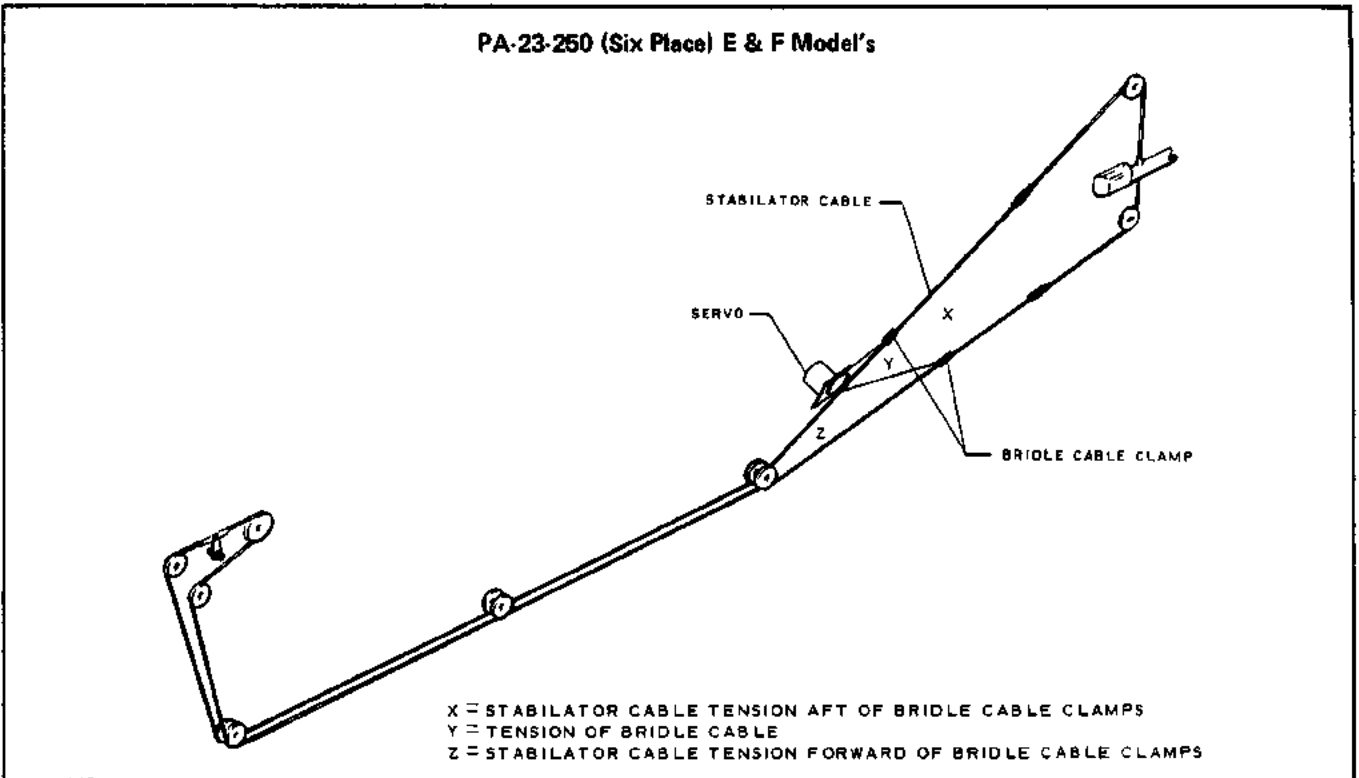

Figure 3-9. Pitch and Rudder Servo Cable Tension Diagram

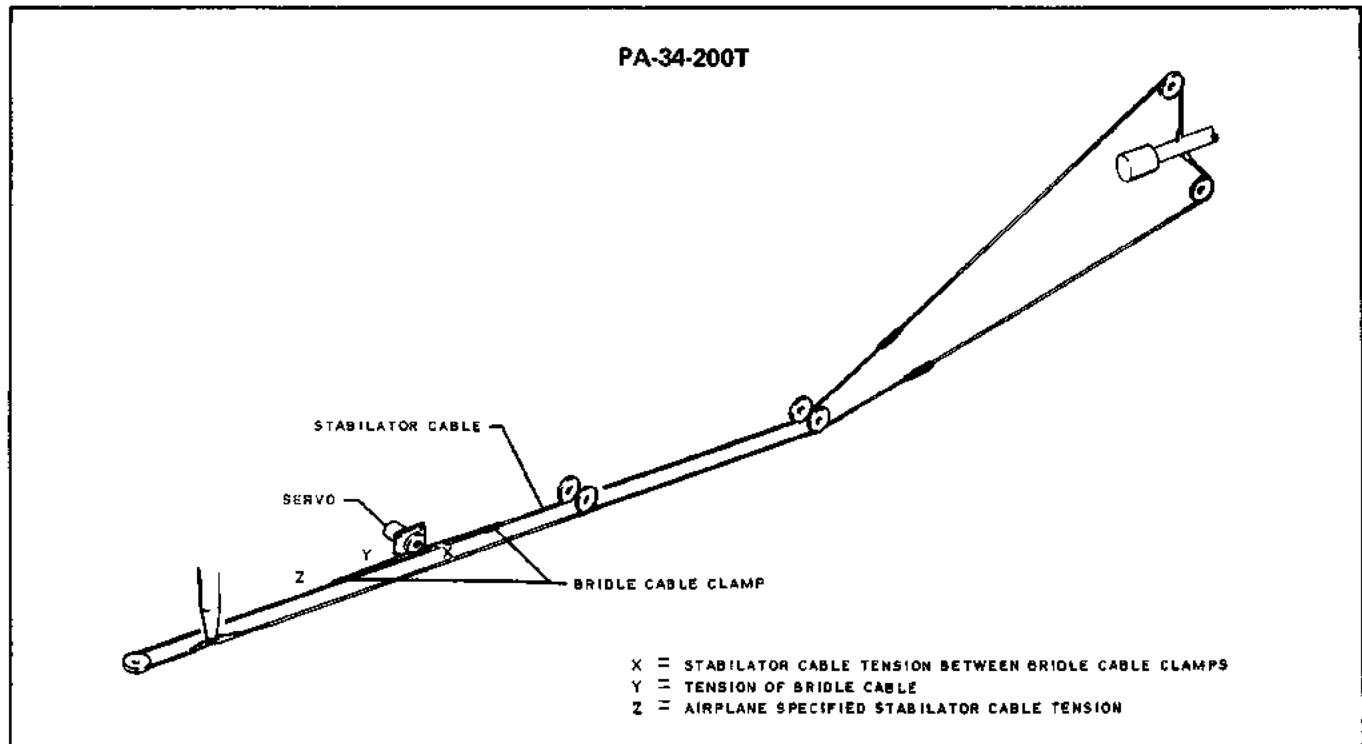
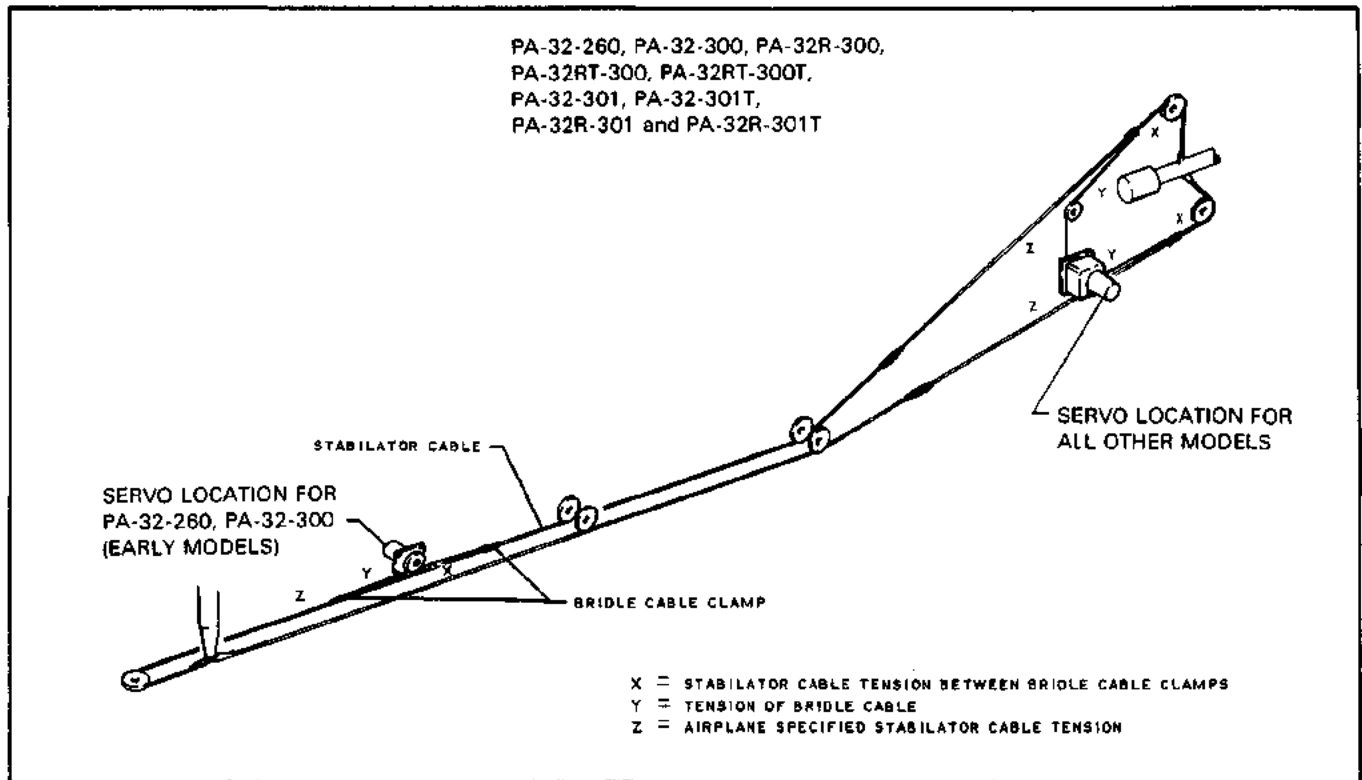

Figure 3-9. Pitch and Rudder Servo Cable Tension Diagram (cont.)

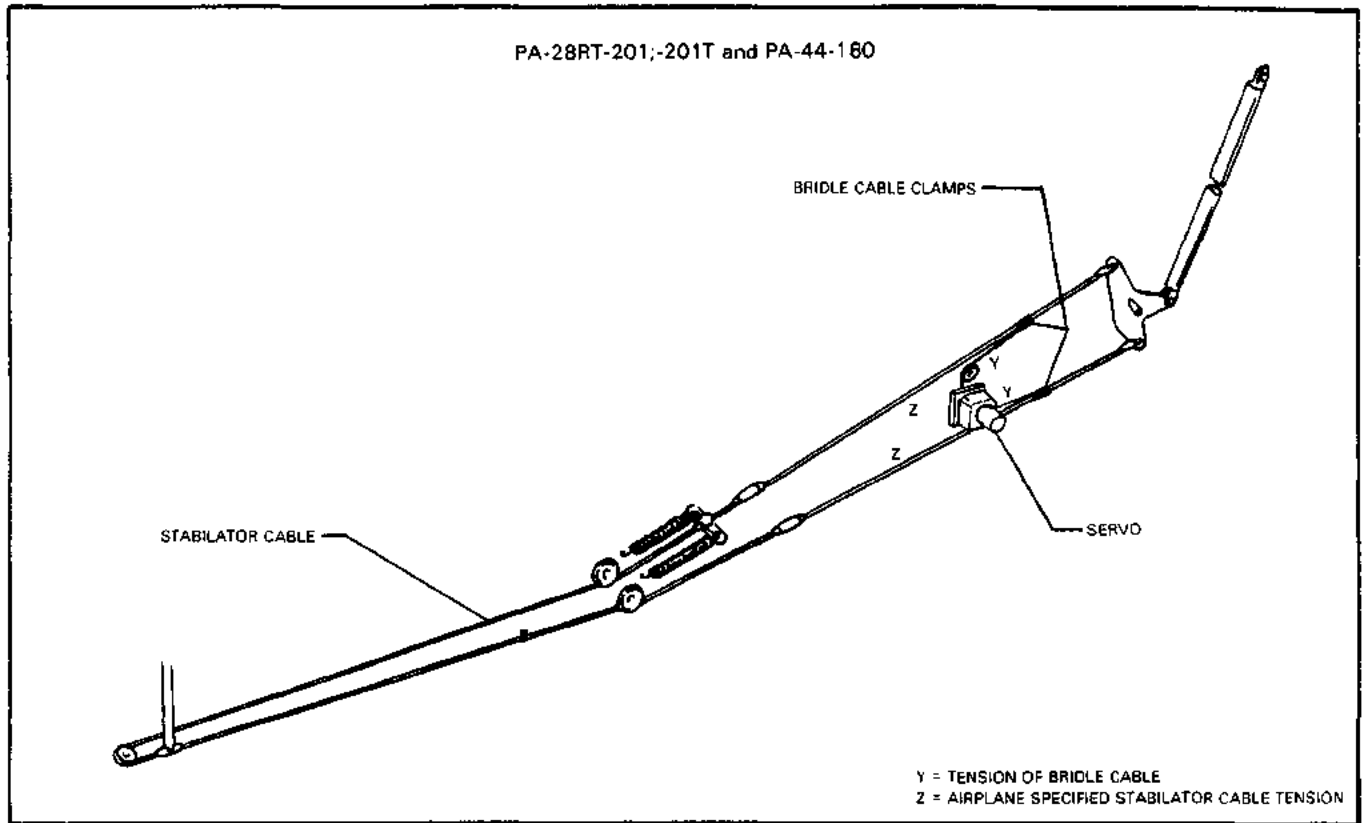

Figure 3-9. Pitch and Rudder Servo Cable Tension Diagram (cont.)

INTENTIONALLY LEFT BLANK

THIS PAGE INTENTIONALLY LEFT BLANK

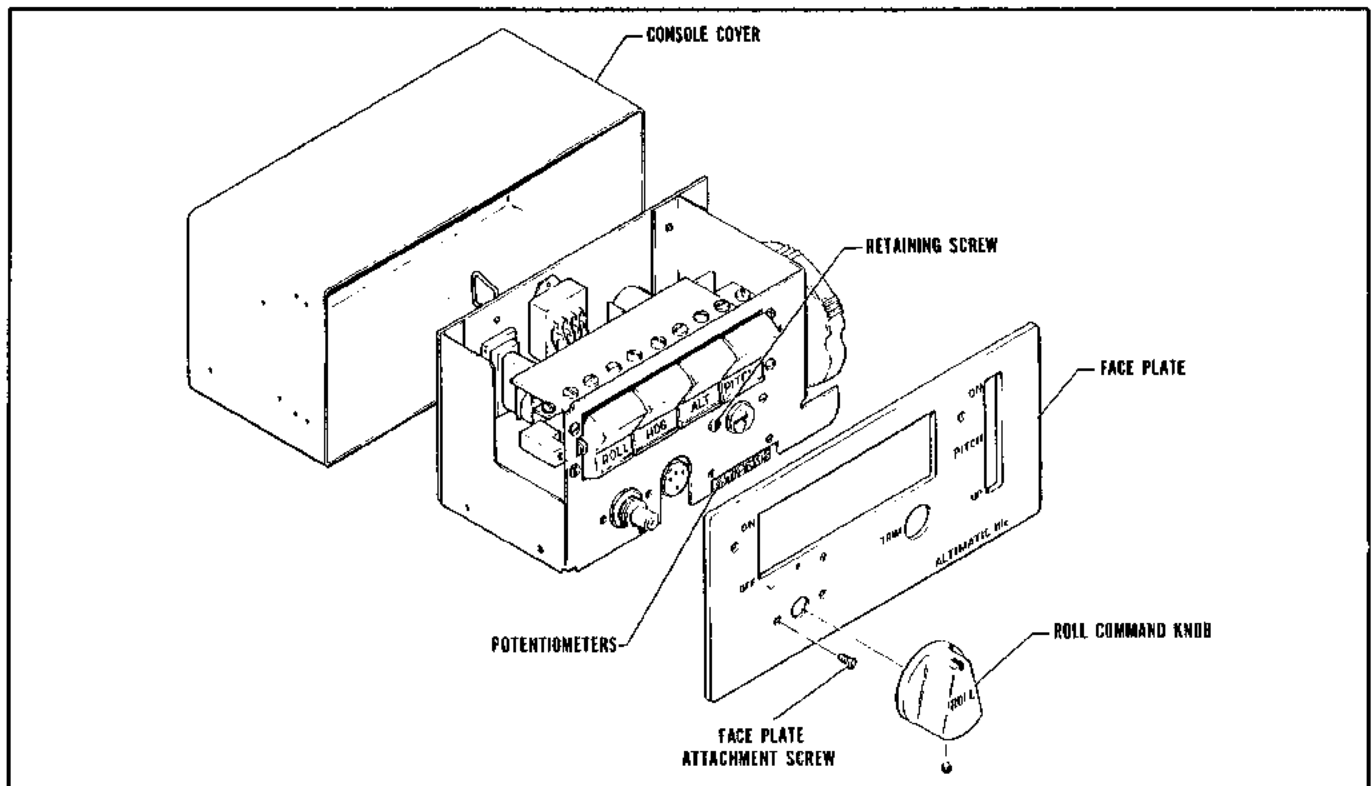

Figure 3-10. AltiMatic IIC Console

3-3. CONSOLE (ALTIMATIC IIC). The exploded view of the AltiMatic IIC Console is shown in illustration form in this section. Although the location varies in each airplane, the Flight Controller is the same in all installations.

3-4. REMOVAL OF CONSOLE. (PA-23-250 Six Place) E & F Models.

The console is located in the lower left section of the instrument panel.

- a. Remove the Roll Command Knob.
- b. Remove the four screws securing the face plate and remove face plate.
- c. Remove the console retaining screw. It is the screw located to the left of the trim meter on the console.
- d. Disconnect the electrical harness plugs CD-20 and CD-40 from the rear of the console.
- e. Remove the console from the airplane.

3-5. INSTALLATION OF CONSOLE. (PA-23-250 Six Place) E & F Models. (Refer to Figure 3-10.)

- a. Place the console in the instrument panel cutout.
- b. Connect the electrical harness plugs, CD-20 and CD-40, to the rear of the console. (Make sure spring clip on CD-20 is secured.)
- c. Secure the console and install and secure the face plate.
- d. Install roll command knob and secure.
- e. Check console operation. (Refer to Section V.)

3-6. REMOVAL OF AUTOPILOT AMPLIFIER. (PA-23-250 Six Place) E & F Model's.

NOTE

The Electronic Trim Amplifier for the Altimatic IIC is located on a mounting bracket which is secured to the top of the Autopilot Amplifier. Therefore, the Electronic Trim Amplifier and Autopilot Amplifier is removed from the airplane as one assembly.

The amplifier is located on the radio shelf in the aft section of the forward baggage compartment.

- a. Access to the amplifier is through the forward baggage compartment door.
- b. Disconnect the electrical harness from the amplifier by removing the two knurled screws from the large amplifier connector and removing the connector from the amplifier.
- c. Disconnect the electrical connectors from the electronic trim amplifier.
- d. Unfasten the two fasteners that secure the amplifier to the mounting bracket.
- e. Remove the autopilot amplifier and electronic trim amplifier from the airplane as one unit.
- f. To remove the electronic trim amplifier and mounting bracket from the autopilot amplifier, simply remove screws and lock washers securing the mounting bracket to the autopilot amplifier.

3-7. REMOVAL OF ELECTRONIC TRIM AMPLIFIER. (PA-23-250 Six Place) E & F Model's.

The electronic trim amplifier is located on the radio shelf in the aft section of the forward baggage compartment.

- a. Access to the amplifier is through the forward baggage compartment door.
- b. Remove amplifier per instructions in previous paragraph.
- c. Remove the four screws securing the electronic trim amplifier to the mounting bracket and remove amplifier from mounting bracket.

3-8. INSTALLATION OF ELECTRONIC TRIM AMPLIFIER. (PA-23-250 Six Place) E & F Models. (Refer to Figure 3-11.)

- a. Place the electronic trim amplifier on the mounting bracket and secure with attaching screws.
- b. Place the mounting bracket with trim amplifier attached on the autopilot amplifier and secure with attaching screws.
- c. Install autopilot amplifier as per the instructions in the following paragraph.

3-9. INSTALLATION OF AUTOPILOT AMPLIFIER. (PA-23-250 Six Place) E & F Models. (Refer to Figure 3-11.)

- a. With the large thirty pin receptacle facing forward, place the amplifier on the mounting bracket located on the radio shelf in the aft section of the forward baggage compartment and secure with the fasteners.
- b. With the cables from the harness fanning to the left side of the airplane, connect the harness to the autopilot amplifier by securing with the two screws previously removed from the receptacle.
- c. Connect the electrical connectors to the electronic trim amplifier.
- d. Check amplifier operation. (Refer to Section V.)

3-10. REMOVAL OF ATTITUDE GYRO. (PA-23-250 Six Place) E & F Model's.

The Attitude Gyro is located in the left instrument panel.

- a. Pull the control wheel, that is at the opposite side of the instrument panel from where the shock-mounted panel is to be removed, to its aftmost position and secure with a cord tied between the wheel and around the seat back.

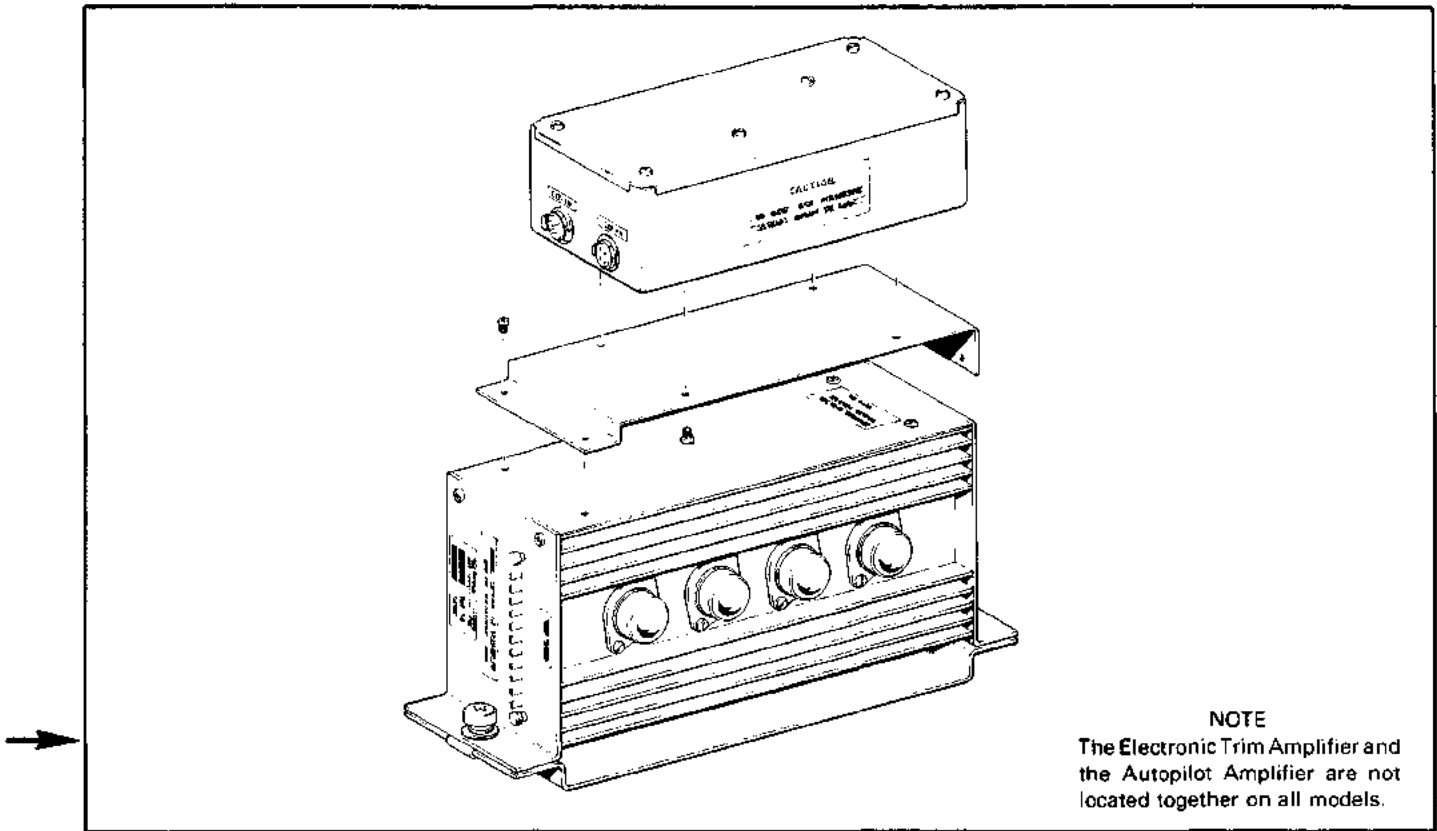

NOTE
The Electronic Trim Amplifier and the Autopilot Amplifier are not located together on all models.

Figure 3-11. AltiMatic III C, Electronic Trim Amplifier and Autopilot Amplifier

- b. Pad the control wheel tube with foam rubber or similar material.
- c. Remove the self-locking nuts that secure the floating panel to its shock mounts. With an open end wrench held next to the back side of the panel, hold the rubber mounts to eliminate twisting as the nuts are being removed.
- d. Pull the panel back and allow it to rest on the padded control wheel tube.
- e. Unscrew the electrical connector from the post light(s).
- f. Disconnect the electrical connection from the instrument.
- g. Disconnect the vacuum line and the relief line from the instrument. Identify hoses to facilitate reinstallation. To prevent contamination, place protective covers over the ends of the hoses and the instrument ports.
- h. Remove the post light(s) by turning off nut.
- i. Remove the screws securing the instrument to the instrument panel and remove instrument.

3-11. INSTALLATION OF ATTITUDE GYRO. (PA-23-250 Six Place) E & F Models. (Refer to Figure 3-12.)

- a. Position the instrument in its proper panel cutout and secure with appropriate screws.
- b. Remove any caps which were placed over the hoses and the instrument ports.
- c. Connect hoses to proper ports of instrument.
- d. Connect the electrical connection to the instrument.
- e. Connect the electrical connector to the post light(s) and tighten connector finger tight.
- f. Ascertain that one end of the ground strap is placed over the panel side of the shock mount stud.
- g. Place the floating panel in position and allow the shock mount attachment studs to protrude through the panel. Install and tighten attachment nuts.

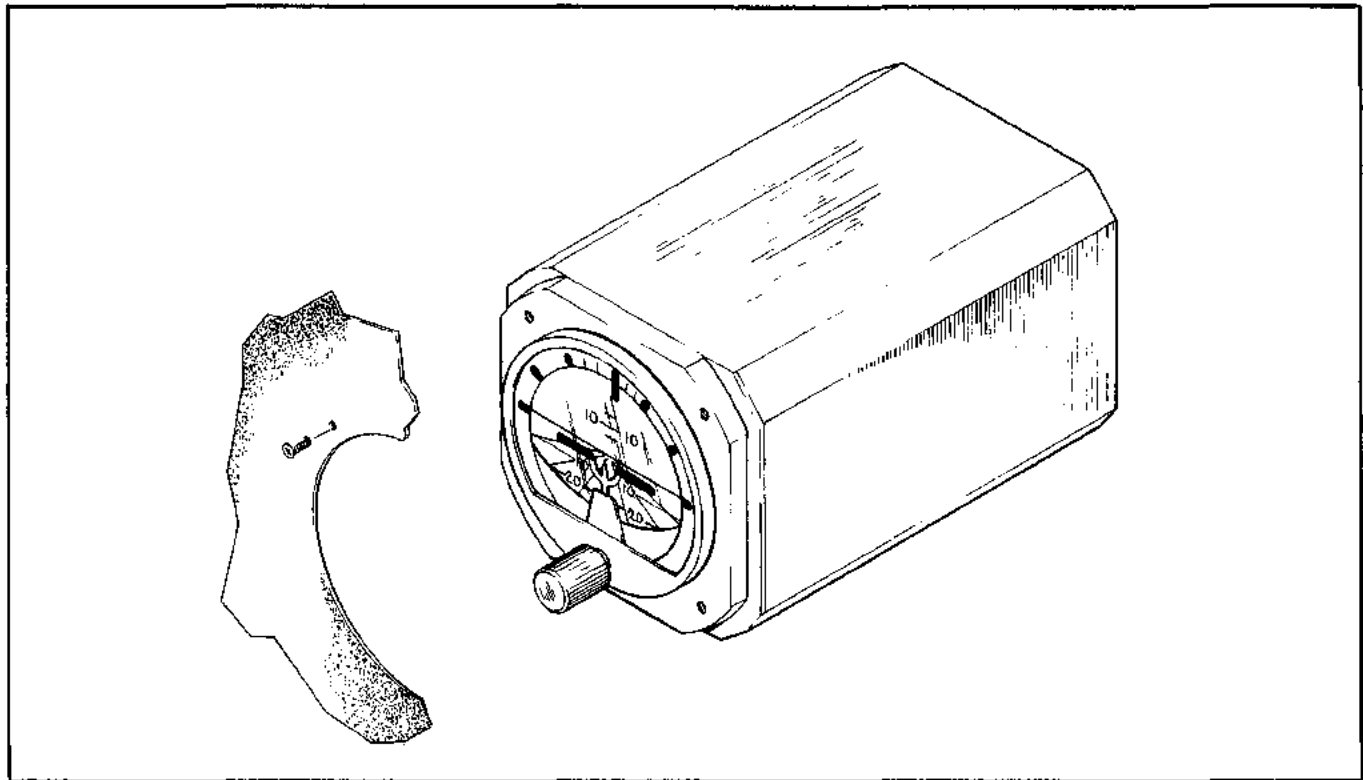

Figure 3-12. AltiMatic III C Attitude Gyro

- h. Remove the padding and release the control wheel.
- i. Check operation of instrument. (Refer to Section V.)
- j. Check post light operation.

3-12. REMOVAL OF DIRECTIONAL GYRO AND/OR HORIZONTAL SITUATION INDICATOR. (PA-23-250 Six Place) E & F Models.

The Directional Gyro and/or Horizontal Situation Indicator is located in the left instrument panel.

- a. Pull the control wheel that is at the opposite side of the instrument panel from where the shock-mounted panel is to be removed, to its aftmost position and secure with a cord tied between the wheel and around the seat back.
- b. Pad the control wheel tube with foam rubber or similar material.
- c. Remove the self-locking nuts that secure the floating panel to its shock mounts. With an open end wrench held next to the back of the panel, hold the rubber mounts to eliminate twisting as the nuts are being removed.
- d. Pull the panel back and allow it to rest on the padded control wheel tube.
- e. Unscrew the electrical connection from the post light(s).
- f. Disconnect the electrical connection from the instrument.
- g. Disconnect the vacuum line and relief line from the instrument. Identify hoses to facilitate reinstallation. To prevent contamination, place protective covers over the ends of the hoses and the instrument ports.
- h. Remove the post light(s) by turning off nut.
- i. Remove the screws securing the instrument to the instrument panel and remove instrument.

3-13. INSTALLATION OF DIRECTIONAL GYRO AND/OR HORIZONTAL SITUATION INDICATOR. (PA-23-250 Six Place) E & F Models. (Refer to Figure 3-13.)

- a. Position the instrument in its proper panel cutout and secure with appropriate screws.
- b. Remove any caps which were placed over the hoses and the instrument ports.
- c. Connect hoses to proper ports of instrument.
- d. Connect the electrical connection to the instrument.
- e. Connect the electrical connector to the post light(s) and tighten connector finger tight.
- f. Ascertain that one end of the ground strap is placed over the panel side of the shock mount stud.
- g. Place the floating panel in position and allow the shock mount attachment studs to protrude through the panel. Install and tighten attachment nuts.
- h. Remove the padding and release the control wheel.
- i. Check operation of instrument. (Refer to Section V.)
- j. Check post light operation.

3-14. REMOVAL OF ALTITUDE HOLD UNIT. (PA-23-250 Six Place) E & F Model's.

The altitude hold unit is located behind the left instrument panel directly forward of the console. The unit is secured to a mounting bracket with strap clamps which in turn is shock mounted to the fuselage.

- a. Access to the unit is from beneath the left instrument panel.
- b. Disconnect the electrical connection from the altitude hold unit.
- c. Disconnect the static hose by releasing the clamps and sliding the hose off the port. To prevent contamination, place protective covers over the ends of the hose and the instrument port.
- d. Loosen the clamp screws securing the unit to the mounting bracket.
- e. Remove the altitude hold unit from the airplane.

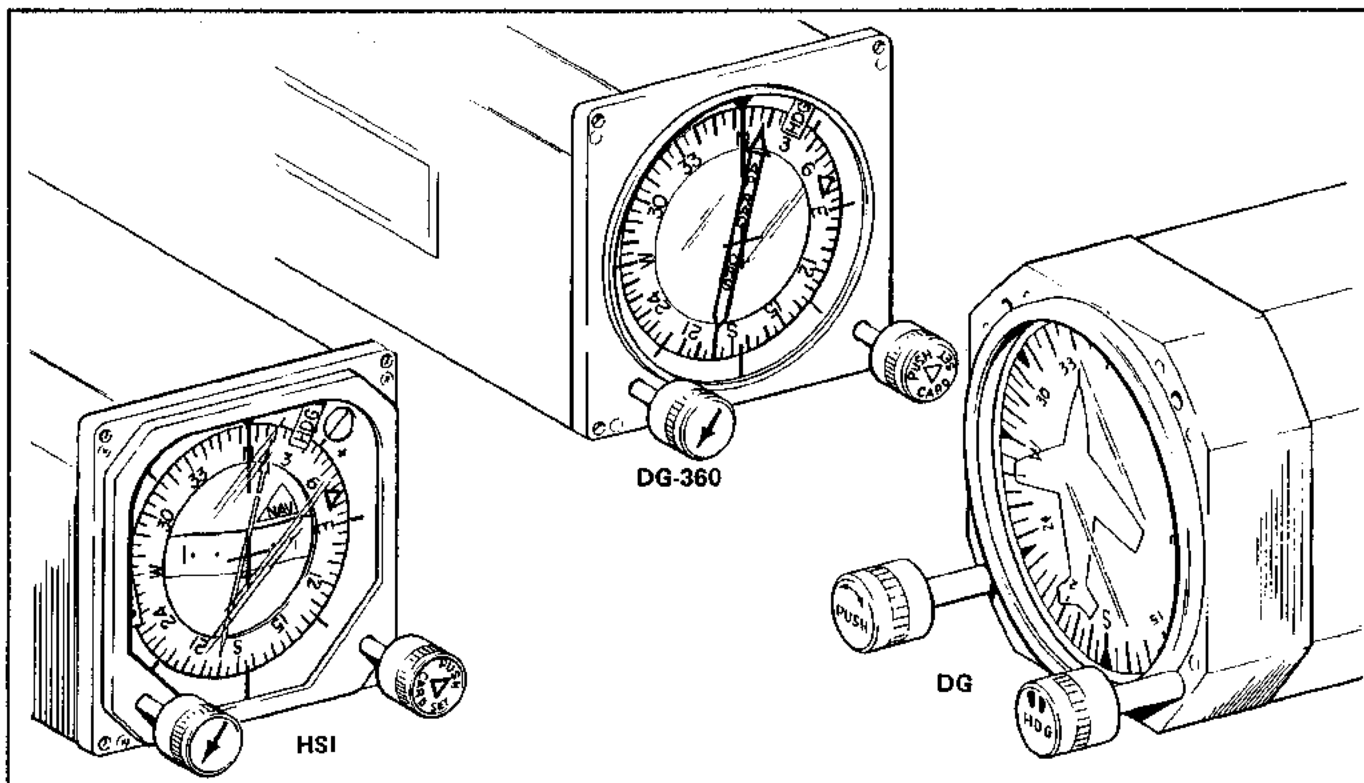

Figure 3-13. AltiMatic III C Directional Gyro/Horizontal Situation Indicator

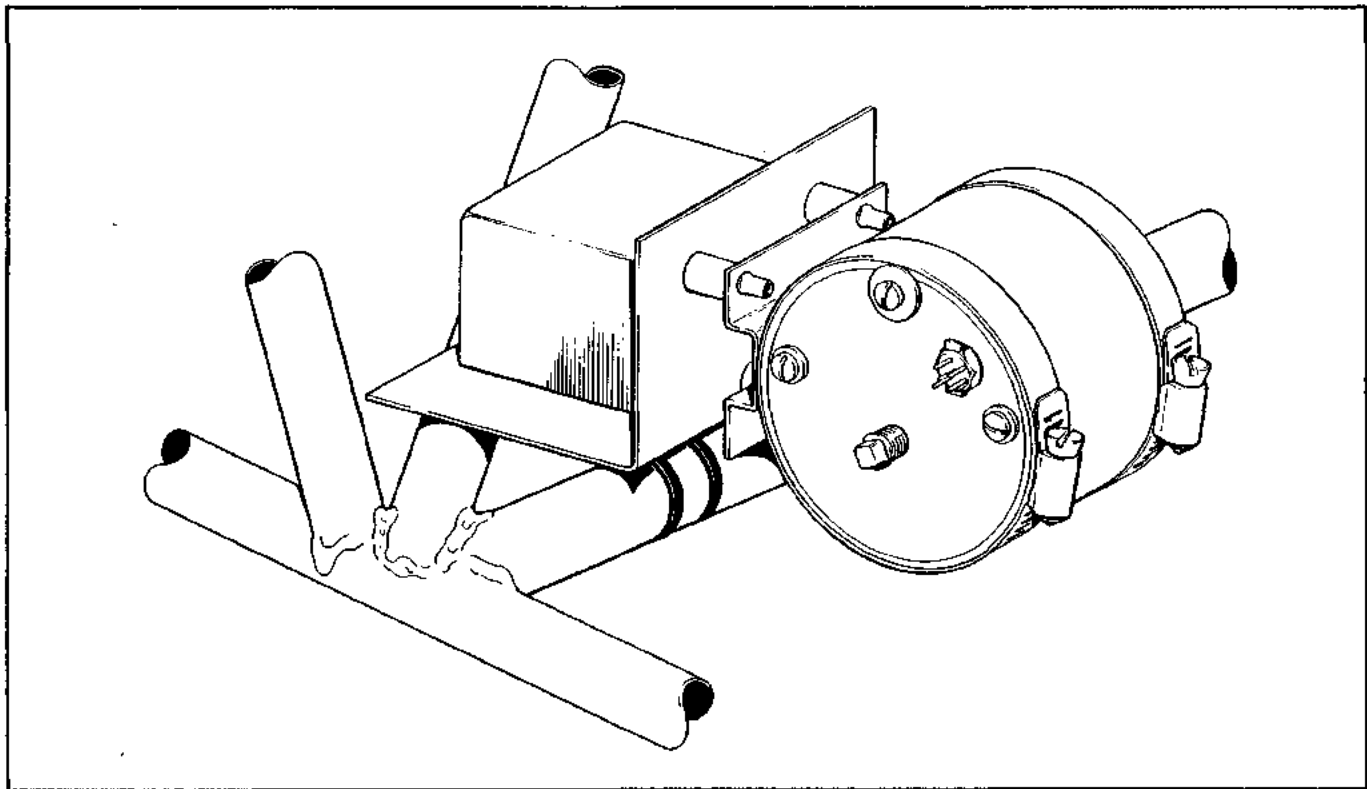

Figure 3-14. AltiMatic III C Altitude Hold Unit (IC407) and Relay Box

3-15. INSTALLATION OF ALTITUDE HOLD UNIT. (PA-23-250 Six Place) E & F Models. (Refer to Figure 3-14.)

- a. Position the altitude hold unit on the mounting bracket located behind the left instrument panel directly forward of the console. Position unit so static port is pointing aft and secure by tightening clamp screws to 5 ± 1 inch pounds.
- b. Remove any caps which were placed over the ends of the hose and the static port.
- c. Connect the hose from the rate of climb indicator to the port marked static on the unit and secure with clamp.
- d. Connect the electrical connection to the unit.
- e. Check operation of altitude hold unit. (Refer to Section V.)

3-16. REMOVAL OF RELAY BOX. (PA-23-250 Six Place) E & F Model's.

The relay box is located on a mounting bracket behind the left instrument panel directly forward of the console.

- a. Access to the relay box is from beneath the left instrument panel.
- b. Disconnect the electrical connection from the relay box.
- c. Remove the screws and spacers securing the relay box to the mounting bracket.
- d. Remove the relay box from the airplane.

3-17. INSTALLATION OF RELAY BOX. (PA-23-250 Six Place) E & F Models. (Refer to Figure 3-14.)

- a. Position the relay box on the mounting bracket located behind the left instrument panel directly forward of the console. With the electrical connector to the right, install spacers and secure with appropriate screws.
- b. Connect the electrical connection to the relay box.
- c. Check operation of relay box. (Refer to Section V.)

3-18. REMOVAL OF ROLL SERVO. (PA-23-250 Six Place) E & F Model's.

The roll servo is located beneath the pilot's seat forward of the main spar. The mounting bracket and roll servo is removed as one unit.

- a. Remove the pilot's seat from the airplane.
- b. Roll back carpet on tunnel beneath pilot's seat over the main spar.
- c. Remove attaching screws in cover over servo assembly and remove cover.
- d. Disconnect the electrical connection from the servo.
- e. Paint the aileron balance cable where the bridle cable clamps are attached and then remove the two bridle cable clamps. (DO NOT paint the bridle cable end terminals as one terminal is painted red to facilitate reinstallation.)
- f. Remove the six bolts, washers and nuts that secure the bracket and roll servo to the airframe and remove servo and mounting bracket from the airplane.
- g. Remove the four bolts, washers and nuts that secure the roll servo to the mounting bracket and remove roll servo from mounting bracket.

3-19. INSTALLATION OF ROLL SERVO. (PA-23-250 Six Place) E & F Models. (Refer to Figure 3-15.)

- a. Insert bridle cable pin in capstan and tighten bridle cable pin lock screw.
- b. Wrap the long end of the bridle cable three-quarters of a turn clockwise on the lower capstan grooves and the short end of the bridle cable with the red ball one and one-quarter turns counterclockwise on the upper capstan grooves.
- c. Adjust the cable guards on the servo to provide a gap of .031 of an inch between the capstan and guard.
- d. Position the roll servo on the mounting bracket and secure with the four bolts, washers and nuts previously removed.

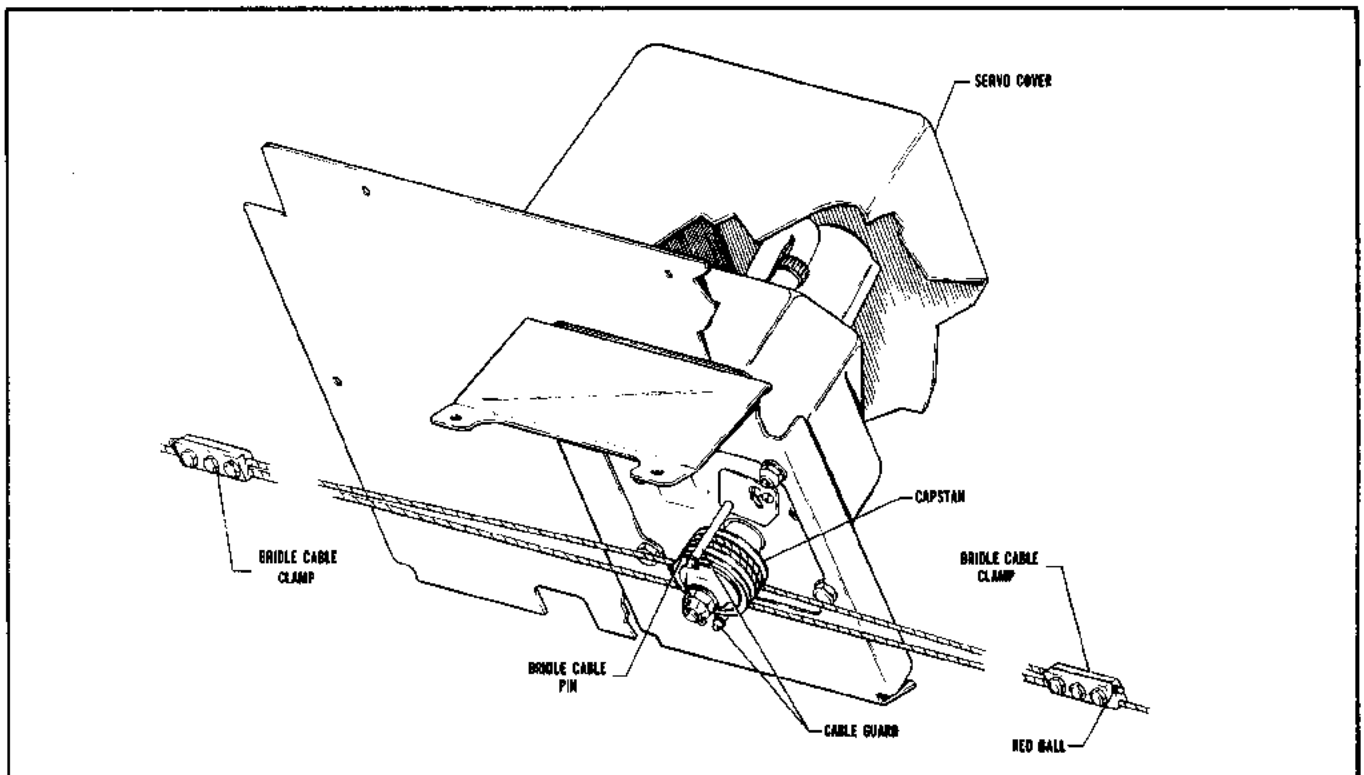

Figure 3-15. Roll Servo Installation, PA-23-250 (Six Place)
E & F Models

e. Place the mounting bracket with roll servo attached in its proper position and secure with the six bolts, washers and nuts previously removed.

f. REFER TO FIGURE 3-8 AND CHECK THAT CONTROL CABLE TENSION (Z) IS ADJUSTED TO 40 + 8 - 0 POUNDS PRIOR TO ATTACHING THE BRIDLE CABLE CLAMPS. Ascertain area on cable where clamp attaches is clean, dry and free of all lubricants and anti-corrosive additives. Attach the bridle cable to the aileron balance cable. The bridle cable is drawn to the balance cable and attached with clamps at the previously painted locations on the balance cable. The end of the bridle cable with the red ball extends toward the right side of the airplane. (Refer to Figure 3-15.) (Should the balance cable not be painted, position the control wheel in neutral and align the bridle cable pin, installed in the capstan, as shown in Figure 3-15.) Adjust the bridle cable clamps so the bridle cable tension (Y) is equal to the control cable tension between the bridle cable clamps (X) as shown in Figure 3-8 without increasing the control cable tension from the bridle cable clamps outward. At no time shall the bridle cable tension be greater than the control cable tension between the clamps. Adjusting the bridle cable tension will lower the control cable tension between the two bridle cable clamps. Torque the bridle cable clamp bolts to 55 ± 5 inch-pounds.

g. Connect the electrical connection to the servo.

CAUTION

Check security of bridle cable clamps and the bridle cable capstan pin. To do this, turn on the master switch and with the roll command knob centered place the roll engage rocker switch in the ON position to engage the roll servo. Turn the control wheel manually to the extreme left and right positions to ascertain the clamps and pin do not change position. Next operate the servo electrically by rotating the roll command knob to its extreme left and right position. Examine the bridle cable to verify the clamps and pin do not change position. The clutch will slip during these operations.

h. Install servo cover on tunnel over main spar and secure with appropriate screws.

i. Install carpet and pilot's seat and secure.

3-20. REMOVAL OF PITCH SERVO. (PA-23-250 Six Place) E & F Model's.

The pitch servo is located aft of the rear baggage compartment on the lower fuselage.

a. Remove attaching screws from the hat shelf panel in rear baggage compartment and remove panel.

b. Remove attaching screws in aft panel of rear baggage compartment and remove panel.

c. Disconnect the electrical connection from the servo.

d. Paint the stabilator control cables where the bridle cable clamps are located and then remove the two bridle cable clamps. (DO NOT paint the bridle cable end terminals as one terminal is painted red to facilitate reinstallation.)

e. Remove the bolts, washers and nuts securing the servo to the mounting bracket and remove the servo from the airplane.

3-21. INSTALLATION OF PITCH SERVO. (PA-23-250 Six Place) E Model. (Refer to Figure 3-16.)

a. Install bridle cable pin in capstan and tighten bridle cable pin lock screw.

b. Wrap the end of the bridle cable with the red terminal one and three-quarter turns clockwise from the bridle cable pin on the upper capstan grooves and the other end of the bridle cable three-quarters of a turn counterclockwise from the bridle cable pin on the lower capstan grooves.

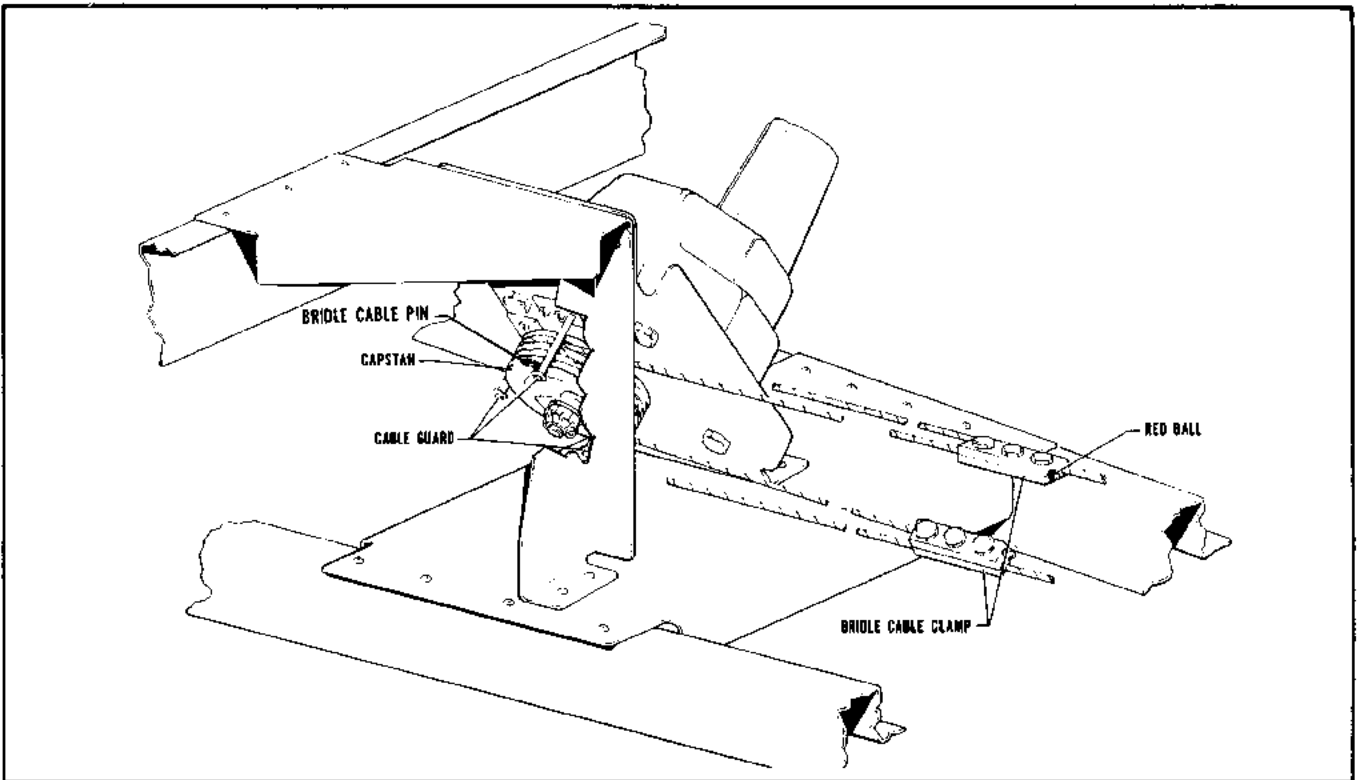

Figure 3-16. Pitch Servo Installation, PA-23-250
(Six Place) E Model

- c. Adjust the cable guards on the servo to provide a gap of .031 of an inch between the capstan and guard.
- d. Position the servo on the mounting bracket and secure with the four bolts, washers and nuts previously removed.
- e. REFER TO FIGURE 3-9 AND CHECK THAT THE CONTROL CABLE TENSION (Z) IS ADJUSTED TO 35 ± 4 POUNDS PRIOR TO ATTACHING THE BRIDLE CABLE CLAMPS. Ascertain area on cable where clamp attaches is clean, dry and free of all lubricants and anti-corrosive additives. Attach the bridle cable to the stabilator control cables. The bridle cable is drawn to the stabilator control cables and attached with clamps at the previously painted locations. The end of the bridle cable with the red ball is attached to the left control cable. (Refer to Figure 3-16.) (Should the stabilator cables not be painted, position the control wheel full forward and with the servo disengaged, align the bridle cable pin installed in the capstan as shown in Figure 3-16. Adjust the bridle cable clamps so that the bridle cable tension (Y) as shown in Figure 3-9 is 15 ± 2 pounds. Check the control cable tension forward of the bridle cable clamps and adjust, if necessary to obtain 35 ± 4 pounds. If the control cables require adjustment, it will be necessary to readjust the bridle cable tension to 15 ± 2 pounds. Torque the bridle cable clamp bolts to 55 ± 5 inch-lbs.
- f. Connect the electrical connection to the servo.

CAUTION

Check security of bridle cable clamps and the bridle cable capstan pin. To do this, turn on the master switch and with the pitch command disc centered place the roll engage rocker switch and the pitch mode switch in the ON position. Move the control wheel manually to the extreme fore and aft positions to ascertain the clamps and pin do not change position. Next operate the servo electrically by rotating the pitch command disc full UP and full DOWN. Examine the bridle cable to verify the clamps and pin do not change position. The clutch will slip during these operations.

- g. Install aft panel in rear baggage compartment and secure with appropriate screws.
- h. Install hat shelf panel in rear baggage compartment and secure with appropriate screws.

3-22. INSTALLATION OF PITCH SERVO. (PA-23-250 Six Place) F Model. (Refer to Figure 3-17.)

- a. Install bridle cable pin in capstan and tighten bridle cable pin lock screw.
- b. Wrap the end of the bridle cable with the red terminal two turns counterclockwise from the bridle cable pin on the upper capstan grooves and the other end of the bridle cable one-half turn clockwise from the bridle cable pin on the lower capstan grooves.
- c. Adjust the cable guards on the servo to provide a gap of .031 of an inch between the capstan and guard.
- d. Position the servo on the mounting bracket and secure with the four bolts, washers and nuts previously removed.
- e. REFER TO FIGURE 3-9 AND CHECK THAT THE CONTROL CABLE TENSION (Z) IS ADJUSTED TO 35 ± 4 POUNDS PRIOR TO ATTACHING THE BRIDLE CABLE CLAMPS. Ascertain area on cable where clamp attaches is clean, dry and free of all lubricants and anti-corrosive additives. Attach the bridle cable to the stabilator control cables. The bridle cable is drawn to the stabilator control cables and attached with clamps at the previously painted locations. The end of the bridle cable with the red ball is attached to the left control cable. (Refer to Figure 3-17.) (Should the stabilator cables not be painted, position the control wheel full forward and with the servo disengaged, align the bridle cable pin installed in the capstan as shown in Figure 3-17.) Adjust the bridle cable clamps so that the bridle cable tension (Y) as shown in Figure 3-9 is 15 ± 2 pounds. Check the control cable tension forward of the bridle cable clamps and adjust, if necessary to obtain 35 ± 4 pounds. If the control cables require adjustment, it will be necessary to readjust the bridle cable tension to 15 ± 2 pounds. Torque the bridle cable clamp bolts to 55 ± 5 inch-lbs.
- f. Connect the electrical connection to the servo.

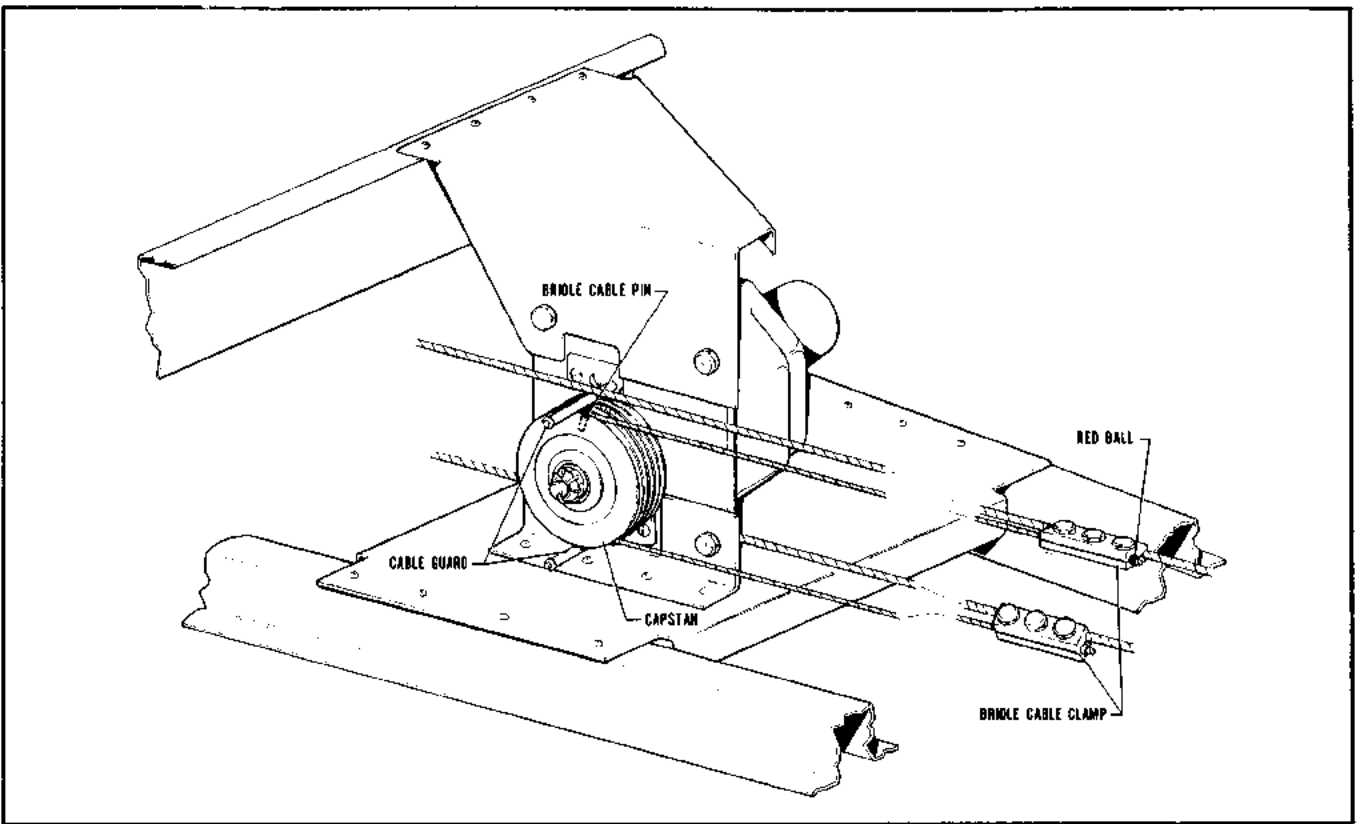

Figure 3-17. Pitch Servo Installation, PA-23-250
(Six Place) F Model

CAUTION

Check security of bridle cable clamps and the bridle cable capstan pin. To do this, turn on the master switch and with the pitch command disc centered place the roll engage rocker switch and the pitch mode switch in the ON position. Move the control wheel manually to the extreme fore and aft positions to ascertain the clamps and pin do not change position. Next operate the servo electrically by rotating the pitch command disc full UP and full DOWN. Examine the bridle cable to verify the clamps and pin do not change position. The clutch will slip during these operations.

- g. Install aft panel in rear baggage compartment and secure with appropriate screws.
- h. Install hat shelf panel in rear baggage compartment and secure with appropriate screws.

3-23. REMOVAL OF PITCH TRIM SERVO. (PA-23-250 Six Place) E & F Models.

The pitch trim servo is located on the upper fuselage area above the ceiling panel in the rear baggage compartment.

- a. Remove the attaching screws in the ceiling panel in the rear baggage compartment and remove ceiling panel.
- b. Remove attaching screws in the hat shelf panel in the rear baggage compartment and remove panel, then remove attaching screws in the aft panel of the rear baggage compartment and remove panel to gain access to turnbuckles to release the trim cable tension.

NOTE

To maintain cable routing of the trim cable during removal and installation of the trim servo, it is recommended that a service aid be fabricated from shop material such as two bridle cable clamps and a short length of cable or two blocks of wood pre-drilled with a bolt and nut inserted to maintain cable routing.

- c. Disconnect the electrical connection from the servo.
- d. Remove the four bolts, washers and nuts securing the servo to the mounting bracket.
- e. Unwrap trim cable from capstan and idler pulley and remove the servo from the airplane.

3-24. INSTALLATION OF PITCH TRIM SERVO. (PA-23-250 six Place) E & F Models. (Refer to Figure 3-18.)

- a. Position the pitch trim servo on the mounting bracket and secure with bolts, washers and nuts previously removed.
- b. Route the trim cable from the forward part of the airplane around the top capstan groove to the idler pulley and around the bottom capstan groove to the aft section of the airplane, completing a figure eight.
- c. Tighten the trim cable (on aircraft incorporating the Stabilator Bungee Spring Installation, the Bungee Spring must be disconnected when adjusting cable tension) to obtain 15 ± 3 lbs. cable tension.
- d. Connect the electrical connection to the servo.
- e. Check servo operation. (Refer to Section V.)
- f. Install aft panel in rear baggage compartment and secure with appropriate screws.
- g. Install hat shelf panel in rear baggage compartment and secure with appropriate screws.
- h. Install ceiling panel in rear baggage compartment and secure with appropriate screws.

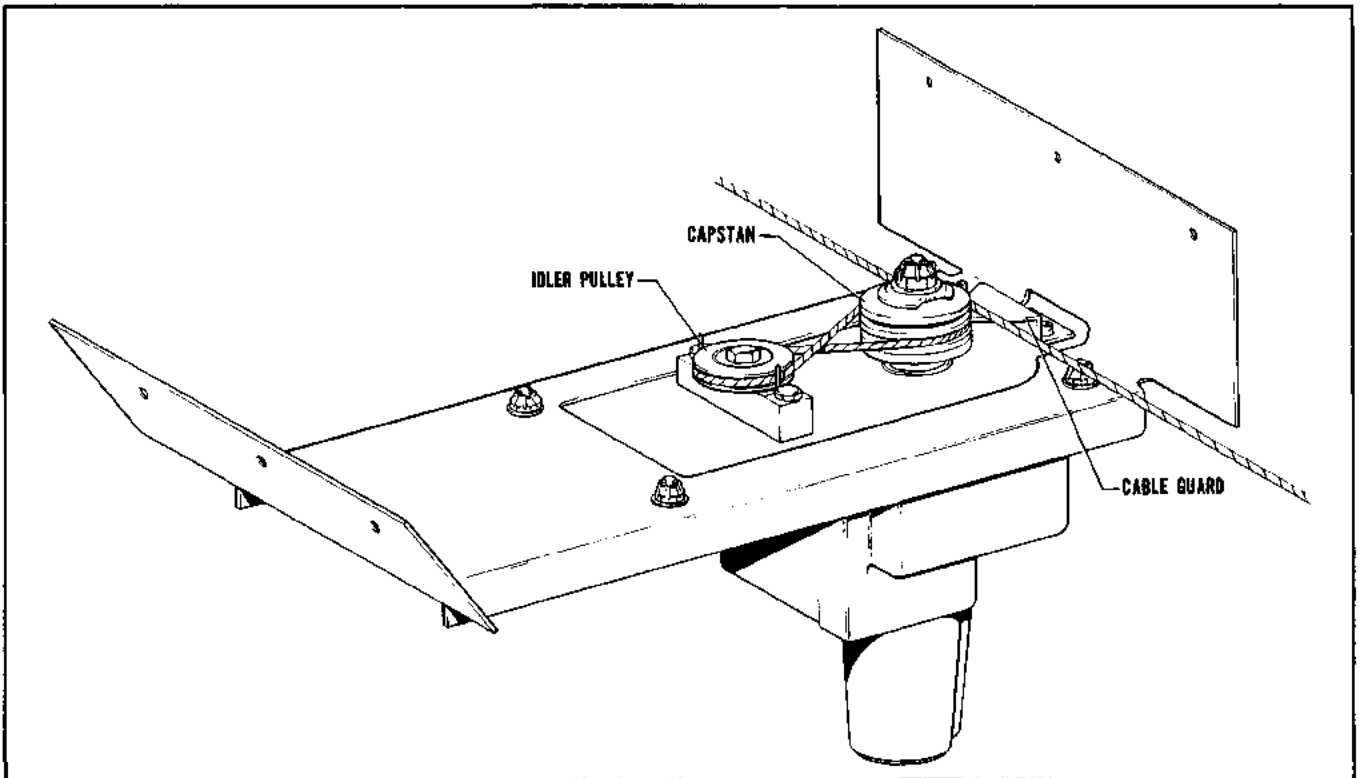

Figure 3-18. Pitch Trim Servo Installation, PA-23-250
(Six Place) E & F Models

3-25. REMOVAL OF GYRO SLAVING AMPLIFIER. (PA-23-250 Six Place) E & F Models.

The gyro slaving amplifier is located on upper right forward section of the pedestal beneath the right instrument panel.

- a. Disconnect the electrical connection from the amplifier.
- b. Remove the screws securing the amplifier to the pedestal.
- c. Remove the amplifier from the airplane.

3-26. INSTALLATION OF GYRO SLAVING AMPLIFIER. (PA-23-250 Six Place) E & F Models. (Refer to Figure 3-19.)

- a. With the electrical connector facing forward place the amplifier on the upper right forward section of the pedestal beneath the right instrument panel and secure with appropriate screws.
- b. Connect the electrical connection to the amplifier.
- c. Check amplifier operation. (Refer to Section V.)

3-27. REMOVAL OF FLUX DETECTOR. (PA-23-250 Six Place) E & F Models.

The flux detector is located aft of the rear baggage area on a mounting bracket on the left side of the fuselage.

- a. Remove attaching screws from the hat shelf panel in rear baggage compartment and remove panel.
- b. Remove the screws attaching the aft panel in the rear baggage area and remove the panel.
- c. Disconnect the electrical connection from the flux detector.
- d. Mark the original position of the flux detector.
- e. Remove the three screws securing the flux detector to the mounting bracket.
- f. Remove the flux detector from the airplane.

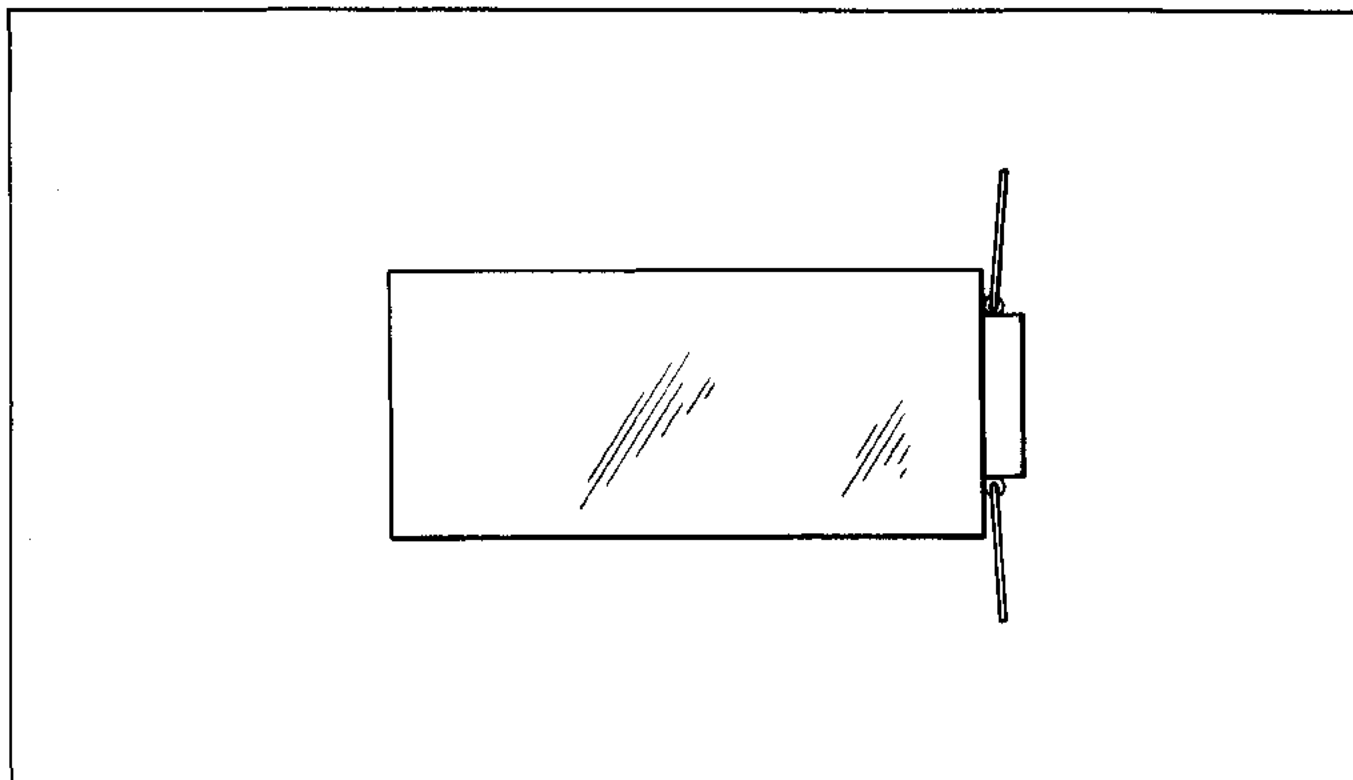

Figure 3-19. AltiMatic III C, Gyro Slaving Amplifier

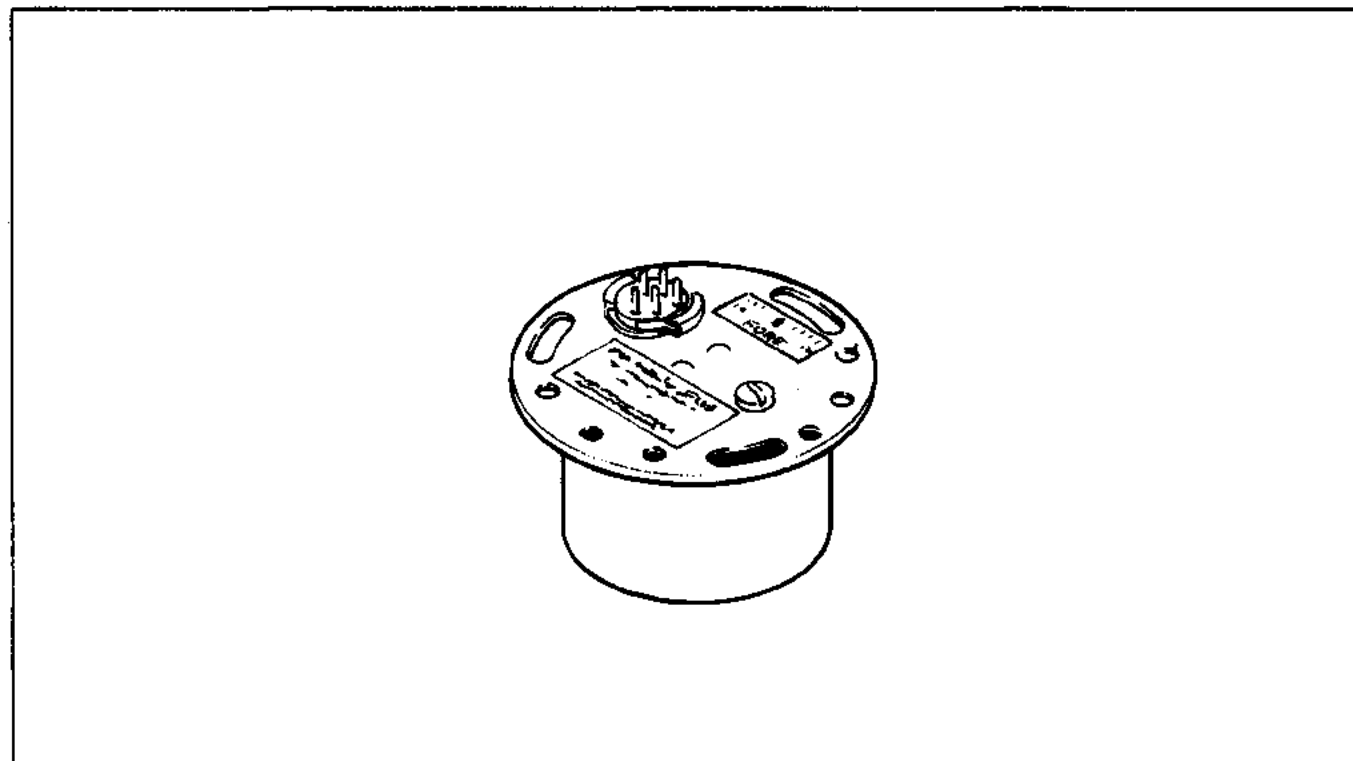

Figure 3-20. AltiMatic III C, Flux Detector

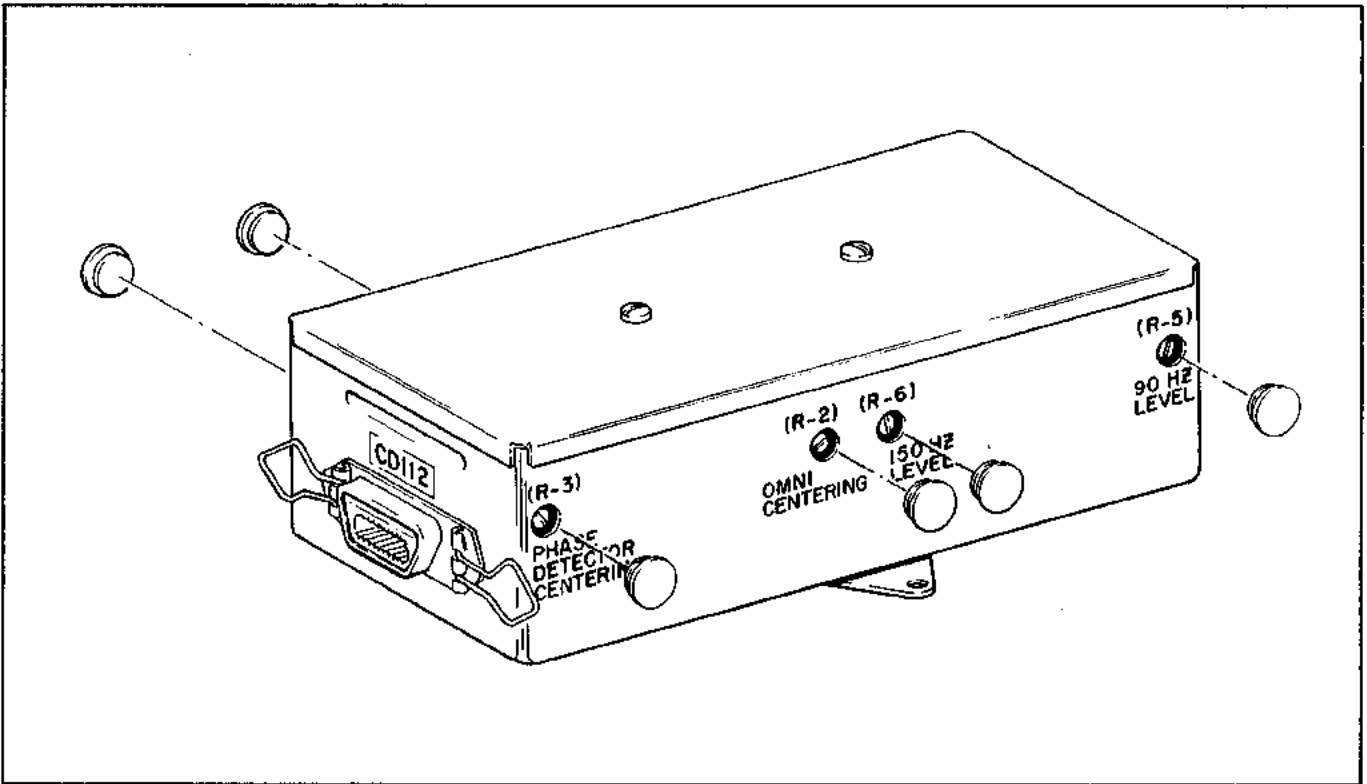

Figure 3-21. AltiMatic III C, NAV Converter (IC707)

3-28. INSTALLATION OF FLUX DETECTOR. (PA-23-250 Six Place) E & F Models. (Refer to Figure 3-20.)

- a. Position the flux detector on the mounting bracket with the label side up and the arrow pointing forward, and secure with original screws.
- b. Connect the electrical connection to the flux detector.
- c. Check flux detector operation. (Refer to Section V.)
- d. Install the aft panel in the rear baggage area and secure with appropriate screws.
- e. Install hat shelf panel in rear baggage compartment and secure with appropriate screws.

3-29. REMOVAL OF NAV CONVERTER (IC707). (PA-23-250 Six Place) E & F Models.

The NAV Converter is located on the left rear section of the radio shelf aft of the forward baggage compartment.

- a. Access to the converter is through the forward baggage compartment door.
- b. Disconnect the electrical connection from the NAV converter.
- c. Remove the three screws and nuts securing the NAV converter to the radio shelf.
- d. Remove the NAV converter from the airplane.

3-30. INSTALLATION OF NAV CONVERTER (IC707). (PA-23-250 Six Place) E & F Models. (Refer to Figure 3-21.)

- a. With the electrical connector facing forward place the NAV converter on the left rear section of the radio shelf aft of the forward baggage compartment and secure with appropriate screws and nuts.
- b. Connect the electrical connection to the NAV converter.
- c. Check NAV converter operation. (Refer to Section V.)

3-31. REMOVAL OF CONSOLE. (PA-31-310, PA-31-325, PA-31-350 and PA-31P)

The console is located in the top of the control quadrant pedestal.

- a. Remove the roll command knob.
- b. Remove the four screws securing the face plate and remove face plate.
- c. Remove the console retaining screw. It is the screw located to the left of the trim meter on the console.
- d. Remove the largest access plate from the right side of the control pedestal.
- e. Disconnect the electrical harness plugs, CD-20 and CD-40, from the rear of the console.
- f. Remove the console from the airplane.

3-32. INSTALLATION OF CONSOLE. (PA-31-310, PA-31-325, PA-31-350 and PA-31P) (Refer to Figure 3-10.)

- a. Place the console in the cutout in the top of the control quadrant pedestal.
- b. Connect the electrical harness plugs CD-20 and CD-40, to the rear of the console. (Make sure spring clip on CD-20 is secured.)
- c. Secure the console and install and secure the face plate.
- d. Install roll command knob and secure.
- e. Install access plate on the right side of the pedestal and secure.
- f. Check console operation. (Refer to Section V.)

3-33. REMOVAL OF AUTOPILOT AMPLIFIER. (PA-31-310, PA-31-325, PA-31-350 and PA-31P)

NOTE

The Electronic Trim Amplifier for the AltiMatic IIC is located on a mounting bracket which is secured to the top of the Autopilot Amplifier. Therefore, the Electronic Trim Amplifier and Autopilot Amplifier is removed from the airplane as one assembly.

The amplifier is located on the right side of the radio shelf aft of the forward baggage compartment.

- a. Access to the amplifier is through the forward baggage compartment door.
- b. Disconnect the electrical harness from the amplifier by removing the two knurled screws from the large amplifier connector and removing the connector from the amplifier.
- c. Disconnect the electrical connectors from the electronic trim amplifier.
- d. Unfasten the two fasteners that secure the amplifier to the mounting bracket.
- e. Remove the autopilot amplifier and electronic trim amplifier from the airplane as one unit.
- f. To remove the electronic trim amplifier and mounting bracket from the autopilot amplifier, simply remove screws and lock washers securing the mounting bracket to the autopilot amplifier.

3-34. REMOVAL OF ELECTRONIC TRIM AMPLIFIER. (PA-31-310, PA-31-325, PA-31-350 and PA-31P)

The electronic trim amplifier is located on the right side of the radio shelf aft of the forward baggage compartment.

- a. Access to the amplifier is through the forward baggage compartment door.
- b. Remove amplifier per instructions in previous paragraph.
- c. Remove the four screws securing the electronic trim amplifier to the mounting bracket and remove amplifier from mounting bracket.

3-35. INSTALLATION OF ELECTRONIC TRIM AMPLIFIER. (PA-31-310, PA-31-325, PA-31-350 and PA-31P) (Refer to Figure 3-11.)

- a. Place the electronic trim amplifier on the mounting bracket and secure with attaching screws.

- b. Place the mounting bracket with trim amplifier attached on the autopilot amplifier and secure with attaching screws.
- c. Install autopilot amplifier as per the instructions in the following paragraph.

3-36. INSTALLATION OF AUTOPILOT AMPLIFIER. (PA-31-310, PA-31-325, PA-31-350 and PA-31P) (Refer to Figure 3-11.)

- a. With the large thirty pin receptacle facing forward, place the amplifier on the mounting bracket located on the right side of the radio shelf aft of the forward baggage compartment and secure with fasteners.
- b. With the cables from the harness fanning to the left side of the airplane, connect the harness to the autopilot amplifier by securing with the two screws previously removed from the receptacle.
- c. Connect the electrical connectors to the electronic trim amplifier.
- d. Check amplifier operation. (Refer to Section V.)

3-37. REMOVAL OF ATTITUDE GYRO. (PA-31-310, PA-31-325, PA-31-350 and PA-31P)

The Attitude Gyro is located in the left instrument panel.

- a. Unsnap the forward side of the instrument panel cover and slide forward enough to allow it to move from its attachment slot. Remove the cover from over the panel.
- b. Pull the control wheel that is at the opposite side of the instrument panel from where the shock-mounted panel is to be removed, to its aftmost position and secure with a cord tied between the wheel and around the seat back.
- c. Pad the control wheel tube with foam rubber or similar material.
- d. Remove the four self-locking nuts that secure the floating panel to its shock mounts. There is one nut located on the panel at each side of the control wheel tube and one nut located at each side of the panel near the top. With an open end wrench held next to the back side of the panel, hold the rubber mounts to eliminate twisting as the nuts are being removed.
- e. Pull the panel back and allow it to rest on the padded control wheel tube.
- f. Unscrew the electrical connector from the post lights.
- g. Disconnect the electrical connection from the instrument.
- h. Disconnect the vacuum line and the relief line from the instrument. Identify hoses to facilitate reinstallation. To prevent contamination, place protective covers over the ends of the hoses and the instrument ports.
- i. Remove the screws securing the instrument to the instrument panel and remove the instrument.

3-38. INSTALLATION OF ATTITUDE GYRO. (PA-31-310, PA-31-325, PA-31-350 and PA-31P) (Refer to Figure 3-12.)

- a. Position the instrument in its proper panel cutout and secure with appropriate screws.
- b. Remove any caps which were placed over the hoses and the instrument ports.
- c. Connect hoses to proper ports of instrument.
- d. Connect the electrical connection to the instrument.
- e. Connect the electrical connector to the post lights and tighten connector finger tight.
- f. Ascertain that one end of the ground strap is placed over the panel side of the shock mount stud.
- g. Place the floating panel in position and allow the shock mount attachment studs to protrude through the panel. Install and tighten attachment nuts.
- h. Remove the padding and release the control wheel.
- i. Check operation of instrument. (Refer to Section V.)
- j. Check post light operation.

3-39. REMOVAL OF DIRECTIONAL GYRO AND/OR HORIZONTAL SITUATION INDICATOR. (PA-31-310, PA-31-325, PA-31-350 and PA-31P)

The Directional Gyro and/or Horizontal Situation Indicator is located in the left instrument panel.

- a. Unsnap the forward side of the instrument panel cover and slide forward enough to allow it to move from its attachment slot. Remove the cover from over the panel.
- b. Pull the control wheel that is at the opposite side of the instrument panel from where the shock-mounted panel is to be removed, to its aftmost position and secure with a cord tied between the wheel and around the seat back.
- c. Pad the control wheel tube with foam rubber or similar material.
- d. Remove the four self-locking nuts that secure the floating panel to its shock mounts. There is one nut located on the panel at each side of the control wheel tube and one nut located at each side of the panel, near the top. With an open end wrench held next to the back side of the panel, hold the rubber mounts to eliminate twisting as the nuts are being removed.
- e. Pull the panel back and allow it to rest on the padded control wheel tube.
- f. Unscrew the electrical connector from the post lights.
- g. Disconnect the electrical connection from the instrument.
- h. Disconnect the vacuum line and relief line from the instrument. Identify hoses to facilitate reinstallation. To prevent contamination, place protective covers over the ends of the hoses and the instrument ports.
- i. Remove the screws securing the instrument to the instrument panel and remove instrument.

3-40. INSTALLATION OF DIRECTIONAL GYRO AND/OR HORIZONTAL SITUATION INDICATOR. (PA-31-310, PA-31-325, PA-31-350 and PA-31P) (Refer to Figure 3-13.)

- a. Position the instrument in its proper panel cutout and secure with appropriate screws.
- b. Remove any caps which were placed over the hoses and the instrument ports.
- c. Connect hoses to proper ports of instrument.
- d. Connect the electrical connection to the instrument.
- e. Connect the electrical connector to the post lights and tighten connector finger tight.
- f. Ascertain that one end of the ground strap is placed over the panel side of the shock mount stud.
- g. Place the floating panel in position and allow the shock mount attachment studs to protrude through the panel. Install and tighten attachment nuts.
- h. Remove the padding and release the control wheel.
- i. Check operation of instrument. (Refer to Section V.)
- j. Check post light operation.

3-41. REMOVAL OF ALTITUDE HOLD UNIT. (PA-31-310, PA-31-325, PA-31-350 and PA-31P)

The altitude hold unit on the early PA-31-310/325, PA-31-350 and all PA-31P model aircraft is located behind the right instrument panel up near the firewall. On the later PA-31-310/325 and PA-31-350 model aircraft the unit is located on the upper right forward side of the bulkhead aft of the radio shelf. This unit is secured to a mounting bracket with strap clamps which in turn is shock mounted to the existing fuselage bracket and/or bulkhead.

- a. Access to the unit is from beneath the right instrument panel and/or by removing the access plate on right side of the nose section at fuselage sta. 81 (PA-31-310/325) or fuselage sta. 57 (PA-31-350).
- b. Disconnect the electrical connection from the altitude hold unit.
- c. Disconnect the static hose by releasing the clamp and sliding the hose off the port. To prevent contamination, place protective covers over the ends of the hose and the instrument port.
- d. Loosen the clamp screws securing the unit to the mounting bracket.
- e. Remove the altitude hold unit from the airplane.

3-42. INSTALLATION OF ALTITUDE HOLD UNIT. (PA-31-310, PA-31-325, PA-31-350 and PA-31P) (Refer to Figure 3-14.)

- a. (Early PA-31-310, PA-31-325, PA-31-350 and all PA-31P model aircraft) Position the altitude hold unit, with the static port pointing aft, on the mounting bracket located behind the right instrument panel up near the firewall. Secure unit by tightening clamp screws to 5 ± 1 inch pounds.
- b. (Later PA-31-310, PA-31-325 and PA-31-350 model aircraft) Position the altitude hold unit, with the static port pointing outboard, on the mounting bracket on the upper right forward side of the bulkhead aft of the radio shelf. Secure unit by tightening clamp screws to 5 ± 1 inch pounds.
- c. Remove any caps which were placed over the ends of the hose and the instrument port.
- d. Connect the hose from the rate of climb indicator to the port marked static on the unit and secure with clamps.
- e. Connect the electrical connection to the unit.
- f. Check operation of altitude hold unit. (Refer to Section V.)
- g. Install access plate on right side of nose section and secure.

3-43. REMOVAL OF RELAY BOX. (PA-31-310, PA-31-325, PA-31-350 and PA-31P)

The relay is located on the existing brake support channel brace behind the left instrument panel to the left of the pilots control column.

- a. Access to the relay box is from beneath the left instrument panel.
- b. Disconnect the electrical connection from the relay box.
- c. Remove the screws securing the relay box to the brake support channel brace.
- d. Remove the relay box from the airplane.

3-44. INSTALLATION OF RELAY BOX. (PA-31-310, PA-31-325, PA-31-350 and PA-31P) (Refer to Figure 3-14.)

a. Position the relay box with electrical connection pointing forward on the brake support channel brace, located behind the left instrument panel to the left of the pilots control column. Secure with appropriate screws.

- b. Connect the electrical connection to the relay box.
- c. Check operation of relay box. (Refer to Section V.)

3-45. REMOVAL OF ROLL SERVO. (PA-31-310, PA-31-325, PA-31-350 and PA-31P)

The roll servo is located in the lower section of the left wing between wing sta. 49.0 and sta. 58.5 aft of the wheel well bulkhead.

- a. Remove the access plate from the bottom wing skin aft of the wheel well bulkhead by removing attaching screws.
- b. Disconnect the electrical connection from the servo.
- c. Prior to removing the roll servo the center inspection plate in the aft bulkhead of the wheel well and the access plate at wing sta. 67.50 must be removed to gain access to the bridle cable clamps.
- d. Paint the aileron balance cable where the bridle cable clamps are located and then remove the two bridle cable clamps. (DO NOT paint the bridle cable end terminals as one terminal is painted red to facilitate reinstallation.)
- e. Remove the four bolts, washers and nuts securing the roll servo to the mounting brackets.
- f. Remove the roll servo from the airplane.

3-46. INSTALLATION OF ROLL SERVO. (PA-31-310, PA-31-325, PA-31-350 and PA-31P) (Refer to Figure 3-22.)

- a. Install bridle cable pin in capstan and tighten bridle cable pin lock screw.
- b. Wrap the bridle cable one-half turn each direction around the capstan from the bridle cable pin.
- c. Adjust the cable guards on the servo to provide a gap of .031 of an inch between the capstan and guard.

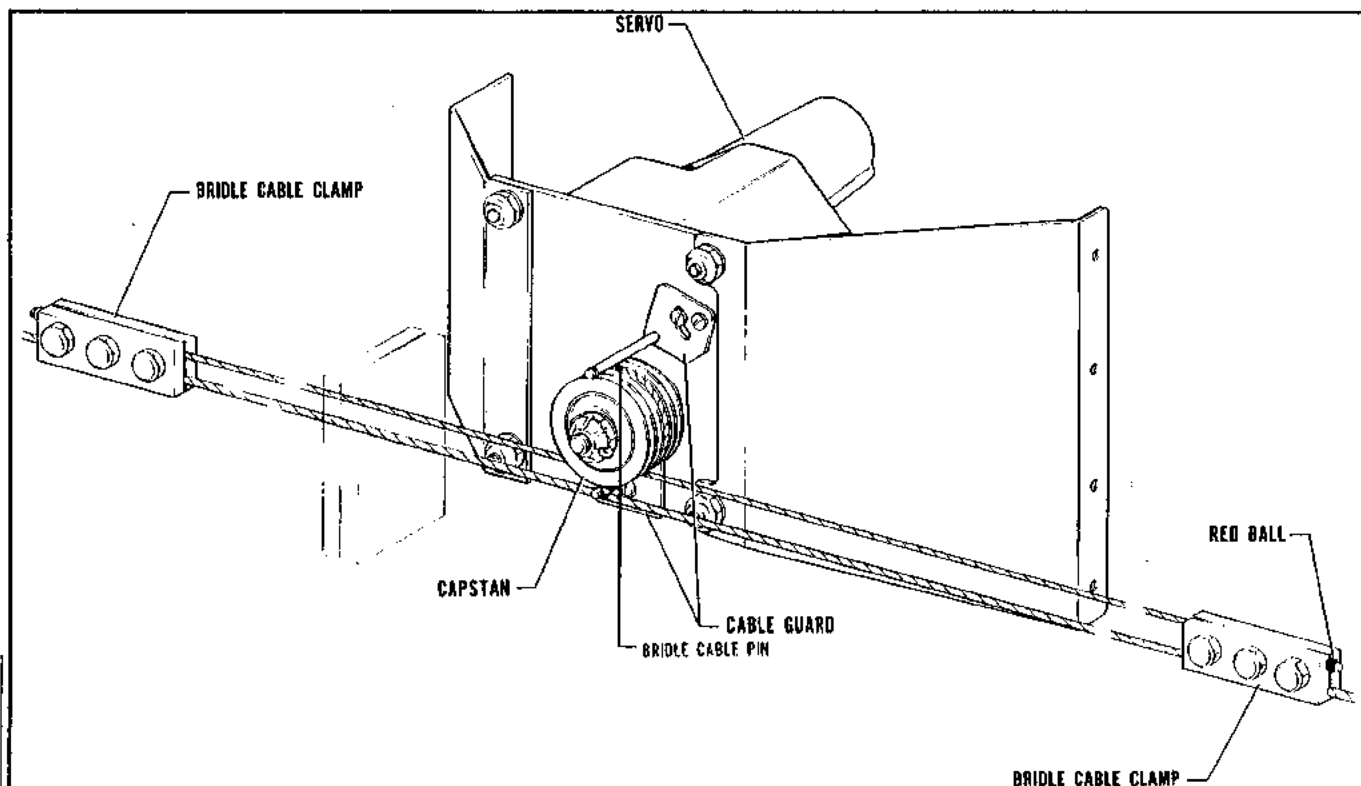

Figure 3-22. Roll Servo Installation, PA-31-310,
PA-31-325, PA-31-350 and PA-31P

d. Position the roll servo on the mounting brackets and secure with the four bolts, washers and nuts previously removed.

e. REFER TO FIGURE 3-8 AND CHECK THAT THE CONTROL CABLE TENSION (Z) IS ADJUSTED TO 35 ± 2 POUNDS PRIOR TO ATTACHING THE BRIDLE CABLE CLAMPS. Ascertain area on cable where clamp attaches is clean, dry and free of all lubricants and anti-corrosive additives. Attach the bridle cable to the aileron control cable. The bridle cable is drawn to the aileron control cable and attached with clamps at the previously painted locations on the control cable. The end of the bridle cable with the red ball extends to the inboard section of the wing. (Should the aileron cable not be painted, position the control wheel in neutral and align the bridle cable pin installed in the capstan as shown in Figure 3-22.) Adjust the bridle cable clamps so that the bridle cable tension (Y) is equal to the control cable tension between the bridle cable clamps (X) 17 ± 2 pounds without increasing the control cable tension from the bridle cable clamps outward. At no time shall the bridle cable tension be greater than the control cable tension between the clamps. Adjusting the bridle cable tension will lower the control cable tension between the two bridle cable clamps. Torque the bridle cable clamp bolts to 55 ± 5 inch pounds.

f. Connect the electrical connection to the servo.

CAUTION

Check security of bridle cable clamps and the bridle cable capstan pin. To do this, turn on the master switch and with the roll command knob centered place the roll engage rocker switch in the ON position to engage the roll servo. Turn the control wheel manually to the extreme left and right position to ascertain the clamps and pin do not change position. Next operate the servo electrically by rotating the roll command knob to its extreme left

and right position. Examine the bridle cable to verify the clamps and pin do not change position. The clutch will slip during these operations.

g. Install and secure the center inspection plate in the aft bulkhead of the wheel well, the access plate at wing sta. 67.50, and the access plate aft of the wheel well bulkhead between wing sta. 49.0 and sta. 58.5.

3-47. REMOVAL OF PITCH SERVO. (PA-31-310, PA-31-325, PA-31-350 and PA-31P)

The pitch servo is located aft of the rear baggage compartment on the center of the bulkhead at sta. 317.75.

a. (PA-31-310, PA-31-325 and PA-31-350) Remove the screws securing the aft panel in the rear baggage compartment and remove panel. Remove the access plate on the left side of the fuselage between sta. 317.75 and sta. 332 by removing the screws securing the access plate to the fuselage.

b. (PA-31P only.) Remove the access plate on the left side of the fuselage between sta. 274 and sta. 296 by turning the screw type fasteners to release the panel and remove the access plates on both the left and right side of the fuselage between sta. 317.75 and sta. 332 by removing the screws securing the access plates to the fuselage.

c. Disconnect the electrical connection from the servo.

d. The bridle cable is attached to the bellcrank. The end of the bridle cable with the turnbuckle is attached to the lower part of the bellcrank.

e. Loosen the bridle cable turnbuckle attached to the lower part of the bellcrank to release the bridle cable tension.

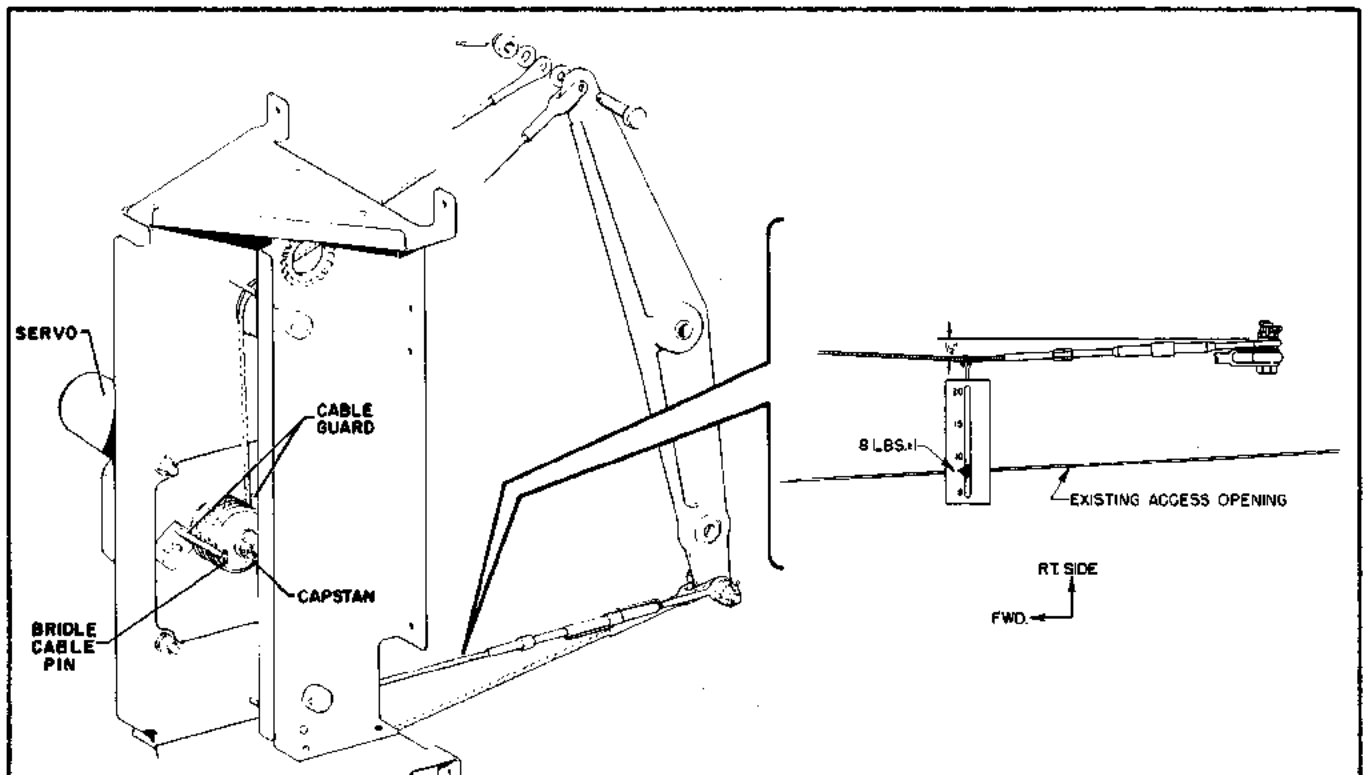

Figure 3-23. Pitch Servo Installation, PA-31-310, PA-31-325, PA-31-350 and PA-31P

- f. Remove the cotter pin and nut from both the upper and lower bolts in the bellcrank to remove the bridle cable.
- g. Remove the four bolts, washers and nuts securing the pitch servo to the mounting bracket.
- h. Remove the pitch servo from the airplane.

3-48. INSTALLATION OF PITCH SERVO. (PA-31-310, PA-31-325, PA-31-350 and PA-31P) (Refer to Figure 3-23.)

- a. Install bridle cable pin in capstan and tighten bridle cable pin lock screw.
- b. Wrap the end of the bridle cable terminating with a turnbuckle one and three-quarter turns clockwise from the pin on the lower capstan grooves and the other end of the bridle cable one and one-quarter turns counterclockwise from the pin on the upper capstan grooves.
- c. Adjust the cable guards on the servo to provide a gap of .031 of an inch between the capstan and guard.
- d. Position the pitch servo on the mounting bracket and secure with the bolts, washers and nuts previously removed.
- e. REFER TO FIGURE 3-9 AND CHECK THAT THE ELEVATOR CABLE TENSION (X) FORWARD OF THE BELLCRANK IS ADJUSTED TO 20 ± 2 POUNDS PRIOR TO ATTACHING THE BRIDLE CABLE TO THE BELLCRANK. Attach the bridle cable to the bellcrank. The bridle cable is drawn around pulleys and installed over both the upper and lower bolts in the bellcrank. The end of the bridle cable with the turnbuckle should be attached to the lower arm of the bellcrank. Secure bridle cable to bellcrank with nut and cotter pin previously removed. With the elevator controls in neutral POSITION align the bridle cable pin installed in the capstan as shown in Figure 3-23. Adjust the turnbuckle until a deflection of 1/2 inch at the midpoint between turnbuckle and bulkhead (sta. 317.75) will produce 8 lbs. ± 1 . (Pull on fish scale or equivalent as shown in fig. 3-23.) Safety the bridle cable turnbuckle.
- f. Connect the electrical connection to the servo.
- g. Check servo operation. (Refer to Section V.)
- h. (PA-31-310, PA-31-325 and PA-31-350 only.) Install aft panel in rear baggage compartment and secure with appropriate screws and install the access plate on the left side of the fuselage between sta. 317.75 and sta. 332 and secure with appropriate screws.
- i. (PA-31P only.) Install the access plate on the left side of the fuselage between sta. 274 and sta. 296 and secure with screw type fasteners and install the access plates on both the left and right side of the fuselage between sta. 317.75 and sta. 332 and secure with appropriate screws.

NOTE

With pitch servo installation completed, the elevator system must be checked for frictional resistance. Depending on the airplane being serviced, refer to either the PA-31, PA-31-350 or PA-31P Airframe Service Manual for the test procedure.

3-49. REMOVAL OF RUDDER SERVO. (PA-31-310, PA-31-325, PA-31-350 and PA-31P)

The rudder servo is located on mounting brackets aft of the rear baggage compartment between sta. 274 and sta. 296.

- a. (PA-31-310, PA-31-325 and PA-31-350 only.) Remove the access plate on the right side of the fuselage between sta. 274 and sta. 296 by removing the screws securing the access plate to the fuselage.
- b. (PA-31P only.) Remove the access plate on the left side of the fuselage between sta. 274 and sta. 296 by turning the screw type fasteners to release the panel and remove the access plates on both the left and right side of the fuselage between sta. 317.75 and sta. 332 by removing the screws securing the access plates to the fuselage.

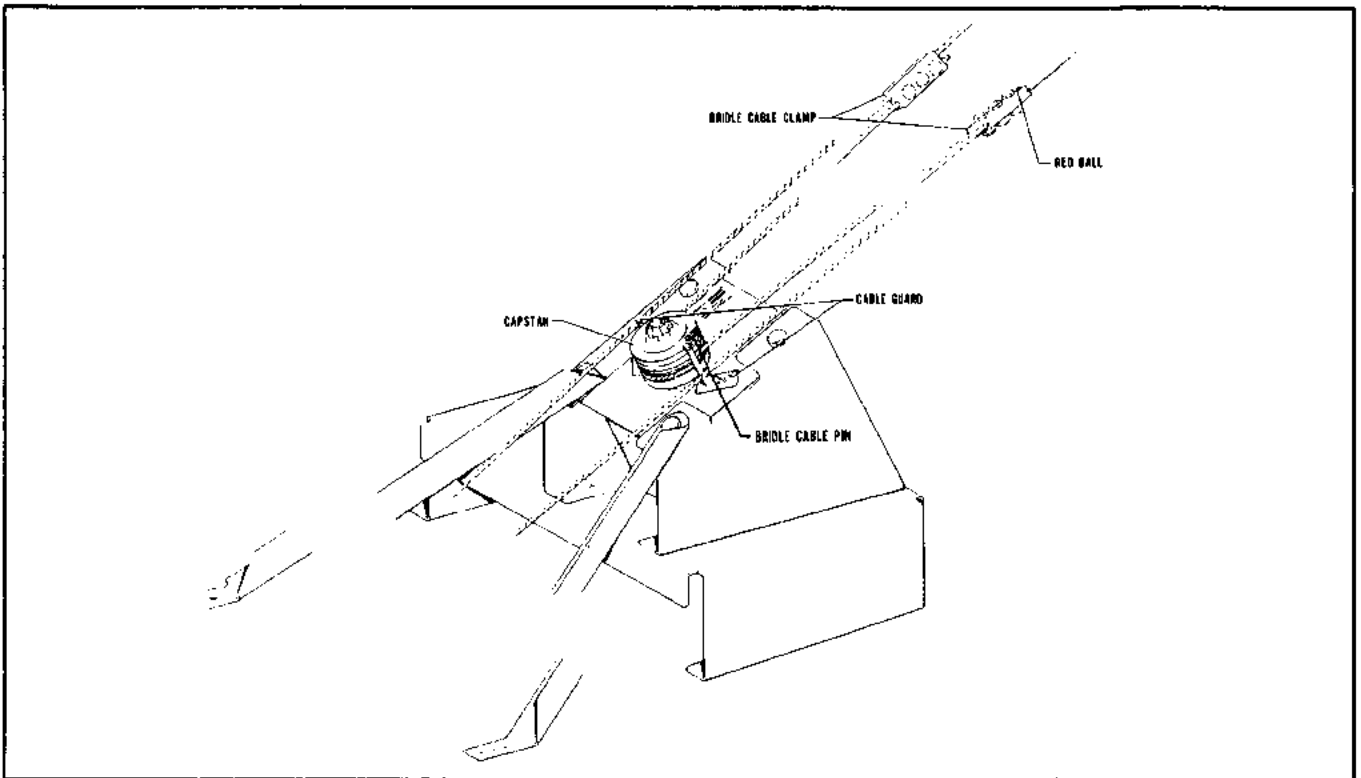

Figure 3-24. Rudder Servo Installation, PA-31-310, PA-31-325, PA-31-350 and PA-31P

- c. Disconnect the electrical connection from the rudder servo.
- d. Paint the rudder balance cables where the bridle cable clamps are located and then remove the two bridle cable clamps. (DO NOT paint the bridle cable end terminals as one terminal is painted red to facilitate reinstallation.)
- e. Remove the four bolts, washers and nuts securing the rudder servo to the mounting brackets.
- f. Remove the servo from the airplane.

3-50. INSTALLATION OF RUDDER SERVO. (PA-31-310, PA-31-325, PA-31-350 and PA-31P) (Refer to Figure 3-24.)

- a. Insert bridle cable pin in capstan and tighten bridle cable pin lock screw.
- b. Wrap the bridle cable three-quarters of a turn in each direction around the capstan from the bridle cable pin.
- c. Adjust the cable guards on the servo to provide a gap of .031 of an inch between the capstan and guard.
- d. Position the rudder servo on the mounting brackets and secure with the bolts, washers and nuts previously removed.
- e. REFER TO FIGURE 3-9 AND CHECK THAT THE CONTROL CABLE TENSION (Z) IS ADJUSTED TO 25 ± 2 POUNDS PRIOR TO ATTACHING THE BRIDLE CABLE CLAMPS. Ascertain the area on the cable where the clamp attaches is clean, dry and free of all lubricants and anti-corrosive additives. Attach the bridle cable to the rudder control cables. The bridle cable is drawn to the rudder control cables and attached with clamps at the previously painted locations on the control cables. The end of the bridle cable with the red ball attaches to the RIGHT control cable. (Should the rudder cables not be painted, position the rudder in neutral and the bridle cable pin installed in the capstan as shown in Figure 3-24.) Adjust the bridle cable clamps, so that the bridle cable tension (Y) as shown in Figure 3-9 is 15 ± 2 -

0 pounds. Check the control cable tension forward of the bridle cable clamps and adjust, if necessary, to obtain 25 ± 2 pounds. If rudder cables require adjustment, it will be necessary to readjust the bridle cable tension to $15 + 0 - 2$ pounds. Torque the bridle cable clamp bolts to 55 ± 5 inch pounds.

- f. Connect the electrical connection to the servo.
- g. Check servo operation. (Refer to Section V.)
- h. (PA-31-310, PA-31-325 and PA-31-350 only.) Install the access plate on the right side of the fuselage between sta. 274 and sta. 296 and secure with appropriate screws.
- i. (PA-31P only.) Install the access plate on the left side of the fuselage between sta. 274 and sta. 296 and secure with screw type fasteners and install the access plates on both the left and right side of the fuselage between sta. 317.75 and 332 and secure with appropriate screws.

3-51. REMOVAL OF PITCH TRIM SERVO. (PA-31-310, PA-31-325, PA-31-350 and PA-31P)

The pitch trim servo is located on the aft side of the fuselage bulkhead at sta. 317.75.

- a. Remove the access plate on the right side of the fuselage between sta. 317.75 and sta. 332 by removing the screws securing the access plate to the fuselage.
- b. (PA-31-310, PA-31-325 and PA-31-350 only.) Remove the access plate on the right side of the fuselage between sta. 274 and sta. 296, by removing the screws securing the access plate to the fuselage, to gain access to turnbuckle to release trim cable tension.
- c. (PA-31P only.) Remove the access plate on the right side of the fuselage between sta. 274 and sta. 296 by turning screw type fasteners to release the panel to gain access to turnbuckle to release trim cable tension.

NOTE

To maintain cable routing of the trim cable during removal and installation of the trim servo, it is recommended that a service aid be fabricated from shop material such as two bridle cable clamps and a short length of cable or two blocks of wood pre-drilled with a bolt and nut inserted to maintain cable routing.

- d. Disconnect the electrical connection from the servo.
- e. Remove the four bolts, washers and nuts securing the trim servo to the mounting brackets.
- f. Unwrap the trim cable from the capstan and idler pulleys.
- g. Remove the trim servo from the airplane.

3-52. INSTALLATION OF PITCH TRIM SERVO. (PA-31-310, PA-31-325, PA-31-350 and PA-31P) (Refer to Figure 3-25.)

- a. Position the pitch trim servo on the mounting brackets and secure with the bolts, washers and nuts previously removed.
- b. Route the trim cable from the forward part of the airplane around the bottom capstan groove and around the forward idler pulley, continuing around the aft idler pulley then around the top capstan groove to the aft section of the airplane.
- c. Tighten the trim cable to obtain 14 ± 2 pounds cable tension.
- d. Connect the electrical connection to the trim servo.
- e. Check trim servo operation. (Refer to Section V.)
- f. (PA-31-310, PA-31-325 and PA-31-350 only.) Install the access plate on the right side of the fuselage between sta. 274 and sta. 296 and secure with appropriate screws.
- g. (PA-31P only.) Install the access plate on the right side of the fuselage between sta. 274 and sta. 296 and secure with screw type fasteners.
- h. Install the access plate on the right side of the fuselage between 317.75 and sta. 332 and secure with appropriate screws.

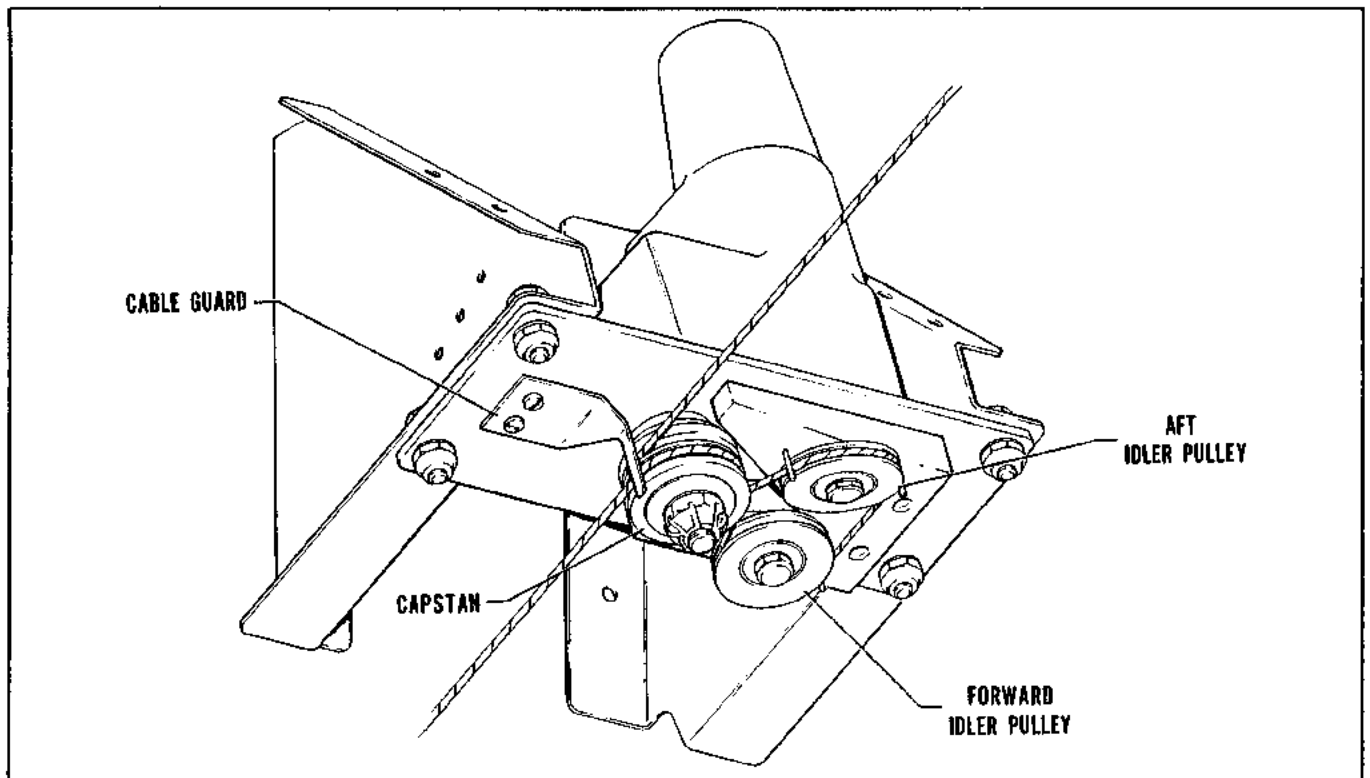

Figure 3-25. Pitch Trim Servo Installation, PA-31-310, PA-31-325, PA-31-350 and PA-31P

3-53. REMOVAL OF YAW DAMPER AMPLIFIER. (PA-31-310, PA-31-325, PA-31-350 and PA-31P)

The yaw damper amplifier is shockmounted on a mounting bracket on the left side of the fuselage aft of the rear baggage compartment.

- a. (PA-31-310, PA-31-325 and PA-31-350 only.) Remove screws securing the aft panel in the rear baggage compartment and remove panel.
- b. (PA-31P only.) Remove the access plate on the left side of the fuselage between sta. 274 and sta. 296 by turning the screw type fasteners to release the access plate.
- c. Disconnect the electrical connection from the yaw damper amplifier.
- d. Remove the four screws, washers and nuts securing the yaw damper amplifier to the mounting bracket.
- e. Disconnect the ground wire from the amplifier case by removing the attaching screw.
- f. Remove the yaw damper amplifier from the airplane.

3-54. INSTALLATION OF YAW DAMPER AMPLIFIER. (PA-31-310, PA-31-325, PA-31-350 and PA-31P) (Refer to Figure 3-26.)

- a. Position the yaw damper amplifier with shockmounts attached on the mounting bracket on the left side of the fuselage aft of the rear baggage compartment and secure with appropriate screw, washers and nuts.
- b. Connect the ground wire to the amplifier case and secure with appropriate screw.
- c. Connect the electrical connection to the amplifier.
- d. Check yaw damper amplifier operation. (Refer to Section V.)
- e. (PA-31-310, PA-31-325 and PA-31-350 only.) Install aft panel in rear baggage compartment and secure with appropriate screws.
- f. (PA-31P only.) Install access plate on the left side of the fuselage between sta. 274 and sta. 296 and secure with screw type fasteners.

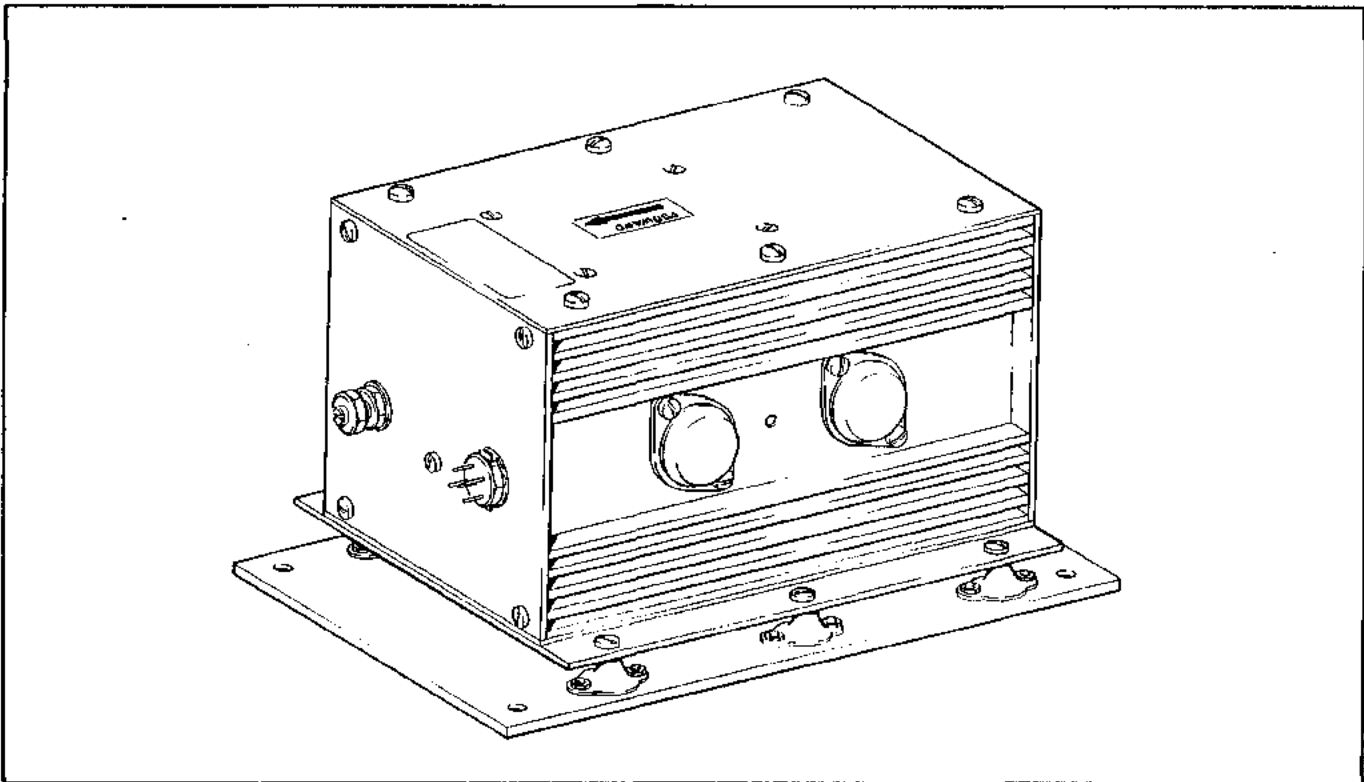

Figure 3-26. Yaw Damper Amplifier Installation,
PA-31-310, PA-31-325, PA-31-350 and PA-31P

3-55. REMOVAL OF GYRO SLAVING AMPLIFIER. (PA-31-310, PA-31-325, PA-31-350 and PA-31P)

The gyro slaving amplifier is located beneath the center floor panel directly behind the main wing spar at fuselage sta. 151.30.

- a. Remove carpet from over the center floor panel directly behind the main spar.
- b. Remove screws securing center floor panel directly aft of main wing spar and remove panel.
(PA-31P only.) Handle panel carefully to avoid damaging sealing gaskets.
- c. Disconnect the electrical connections from the amplifier.
- d. Remove the screws securing the amplifier to the bulkhead.
- e. Remove the amplifier from the airplane.

3-56. INSTALLATION OF GYRO SLAVING AMPLIFIER. (PA-31-310, PA-31-325, PA-31-350 and PA-31P) (Refer to Figure 3-19.)

- a. With electrical connector facing inboard place the amplifier on the bulkhead at fuselage sta. 151.30 and secure with appropriate screws.
- b. Connect the electrical connections to the amplifier.
- c. Check amplifier operation. (Refer to Section V.)
- d. (PA-31-310, PA-31-325 and PA-31-350 only.) Install center floor panel and secure with appropriate screws.
- e. (PA-31P only.) Ascertain that floor panel sealing gaskets are clean and undamaged prior to installation of panel. Install center floor panel and tighten all screws evenly around panel to prevent cabin pressure leaks.
- f. Install carpet and secure.

3-57. REMOVAL OF FLUX DETECTOR. (PA-31-310, PA-31-325, PA-31-350 and PA-31P)

The flux detector is located in the left wing beneath the top access plate outboard of wing sta. 221.50.

- a. Remove the screws securing the access plate to the wing and remove access plate.
- b. Disconnect the electrical connection from the flux detector.
- c. Mark the original position of the flux detector.
- d. Remove the three screws securing the flux detector to the mounting bracket.
- e. Remove the flux detector from the airplane.

3-58. INSTALLATION OF FLUX DETECTOR. (PA-31-310, PA-31-325, PA-31-350 and PA-31P) (Refer to Figure 3-20.)

- a. Position the flux detector on the mounting bracket with the label side up and the arrow pointing forward, and secure with original screws.
- b. Connect the electrical connection to the flux detector.
- c. Check flux detector operation. (Refer to Section V.)
- d. Install the top access plate in the left wing, outboard of wing sta. 221.50 and secure with appropriate screws.

3-59. REMOVAL OF NAV CONVERTER (1C707). (PA-31-310, PA-31-325, PA-31-350 and PA-31P)

The NAV converter is located on the left radio shelf aft of the forward baggage compartment.

- a. Access to the converter is through the forward baggage compartment door.
- b. Disconnect the electrical connection from the NAV converter.
- c. Remove the three screws and nuts securing the NAV converter to the radio shelf.
- d. Remove the NAV converter from the airplane.

3-60. INSTALLATION OF NAV CONVERTER (1C707). (PA-31-310, PA-31-325, PA-31-350 and PA-31P) (Refer to Figure 3-21.)

- a. With the electrical connection facing forward place the NAV converter on the left radio shelf aft of the forward baggage compartment and secure with appropriate screws and nuts.
- b. Connect the electrical connection to the NAV converter.
- c. Check NAV converter operation. (Refer to Section V.)

3-61. REMOVAL OF CONSOLE. (PA-32-260, PA-32-300, PA-32R-300, PA-32RT-300, PA-32RT-300T, PA-32-301, PA-32-301T, PA-32R-301 and PA-32R-301T.)

The console is located in the lower left section of the instrument panel.

- a. Remove the roll command knob.
- b. Remove the four screws securing the face plate and remove face plate.
- c. Remove the console retaining screw. It is the screw located to the left of the trim meter on the console.
- d. Disconnect the electrical harness plugs CD-20 and CD-40 from the rear of the console.
- e. Remove the console from the airplane.

3-62. INSTALLATION OF CONSOLE. (PA-32-260, PA-32-300, PA-32R-300, PA-32RT-300, PA-32RT-300T, PA-32-301, PA-32-301T, PA-32R-301 and PA-32R-301T) (Refer to Figure 3-10.)

- a. Place the console in the instrument panel cutout.
- b. Connect the electrical harness plugs, CD-20 and CD-40, to the rear of the console. (Make sure spring clip on CD-20 is secured.)
- c. Secure the console and install and secure the face plate.
- d. Install roll command knob and secure.
- e. Check console operation. (Refer to Section V.)

3-63. REMOVAL OF AUTOPILOT AMPLIFIER. (PA-32-260, S/N 32-7500001 to 7700023; PA-32-300, S/N 32-7540001 to 7840045 and PA-32R-300, S/N 32R-7680001 to 7780417)

NOTE

The Electronic Trim Amplifier for the AltiMatic IIC on the aircraft listed above is located on a mounting bracket which is secured to the top of the autopilot amplifier. Therefore, the Electronic Trim Amplifier and Autopilot Amplifier is removed from the airplane as one assembly.

The amplifier is located behind the right instrument panel, directly forward of the circuit breaker panel.

- a. Access to the amplifier is from beneath the right instrument panel.
- b. Disconnect the electrical harness from the amplifier by removing the two knurled screws from the large amplifier connector and removing the connector from the amplifier.
- c. Disconnect the electrical connectors from the electronic trim amplifier.
- d. Unfasten the two fasteners that secure the amplifier to the mounting bracket.
- e. Remove the autopilot amplifier and electronic trim amplifier from the airplane as one unit.
- f. To remove the electronic trim amplifier and mounting bracket from the autopilot amplifier, simply remove screws and lockwashers securing the mounting bracket to the autopilot amplifier.

3-64. REMOVAL OF ELECTRONIC TRIM AMPLIFIER. (PA-32-260, S/N 32-7500001 to 7700023 and PA-32-300, S/N 32-7540001 to 7840045)

The electronic trim amplifier is located behind the right instrument panel directly forward of the circuit breaker panel.

- a. Access to the amplifier is from beneath the right instrument panel.
- b. Remove amplifier per instructions in previous paragraph.
- c. Remove the four screws securing the electronic trim amplifier to the mounting bracket and remove amplifier from mounting bracket.

3-65. INSTALLATION OF ELECTRONIC TRIM AMPLIFIER. (PA-32-260, S/N 32-7500001 to 7700023 and PA-32-300, S/N 32-7540001 to 7840045) (Refer to Figure 3-11.)

- a. Place the electronic trim amplifier on the mounting bracket and secure with attaching screws.
- b. Place the mounting bracket with trim amplifier attached on the autopilot amplifier and secure with appropriate screws.
- c. Install autopilot amplifier as per the instructions in the following paragraph.

3-66. INSTALLATION OF AUTOPILOT AMPLIFIER. (PA-32-260, S/N 32-7500001 to 7700023; PA-32-300, S/N 32-7540001 to 7840045 and PA-32R-300, S/N 32R-7680001 to 7780417) (Refer to Figure 3-11.)

- a. With the large thirty pin receptacle pointing upward, place the amplifier on the mounting bracket located behind the right instrument panel, directly forward of the circuit breaker panel and secure with fasteners.
- b. With the cable from the harness fanning to the left side of the airplane, connect the harness to the autopilot amplifier by securing with two screws previously removed from the receptacle.
- c. Connect the electrical connectors to the electronic trim amplifier.
- d. Check amplifier operation. (Refer to Section V.)

3-67. REMOVAL OF AUTOPILOT AMPLIFIER. (PA-32-260, S/N 32-7800001 and up; PA-32-300, S/N 32-7840046 and up; PA-32R-300, S/N 32R-7780418 and up; PA-32RT-300, PA-32RT-300T, PA-32-301, PA-32-301T, PA-32R-301 and PA-32R-301T.)

NOTE

The Electronic Trim Amplifier and the Autopilot Amplifier for the AltiMatic IIC are not located together on the above models. Therefore, the Electronic Trim Amplifier and Autopilot Amplifier are not removed as one assembly.

The amplifier is located beneath the floor panel under the center set of seats.

- a. Remove the center seats and floor panel directly behind the main spar by removing the seat belts and screws. Remove the floor panel from the airplane.
- b. Disconnect the electrical harness from the amplifier by removing the two knurled screws from the large amplifier connector and removing the connector from the amplifier.
- c. Unfasten the two fasteners that secure the amplifier to the mounting bracket.
- d. Remove the amplifier from the airplane.

3-68. INSTALLATION OF AUTOPILOT AMPLIFIER. (PA-32-260, S/N 32-7800001 and up; PA-32-300, S/N 32-7840046 and up; PA-32R-300, S/N 32R-7780418 and up; PA-32RT-300, PA-32RT-300T, PA-32-301, PA-32-301T, PA-32R-301 and PA-32R-301T) (Refer to Figure 3-11.)

- a. With the large thirty pin receptacle pointing outward for the PA-32R-300, and inward for the other models, place the amplifier on the mounting bracket located beneath the floor panel under the center set of seats and secure with fasteners.
- b. Connect the harness to the autopilot amplifier by securing with two screws previously removed from receptacle.
- c. Check amplifier operation. (Refer to Section V.)

3-69. REMOVAL OF ELECTRONIC TRIM AMPLIFIER. (PA-32-260, S/N 32-7800001 and up; PA-32-300, S/N 32-7840046 and up; PA-32R-300, PA-32RT-300, PA-32RT-300T, PA-32-301, PA-32-301T, PA-32R-301 and PA-32R-301T)

The electronic trim amplifier is located aft of the rear baggage compartment mounted on the second stringer above the floor on the left side of the airplane.

- a. Access to the amplifier is through the rear baggage area.
- b. Remove attaching screws in aft panel of rear baggage compartment and remove panel.
- c. Disconnect the electrical connectors from the electronic trim amplifier.
- d. Remove the four screws securing the amplifier to the mounting bracket and remove the amplifier from the airplane.

3-70. INSTALLATION OF ELECTRONIC TRIM AMPLIFIER. (PA-32-260, S/N 32-7800001 and up; PA-32-300, S/N 32-7840046 and up; PA-32R-300, PA-32RT-300, PA-32RT-300T, PA-32-301, PA-32-301T, PA-32R-301 and PA-32R-301T) (Refer to Figure 3-11.)

- a. Place the electronic trim amplifier on the bracket and secure with attaching screws.
- b. Connect the electrical connectors to the amplifier.
- c. Check amplifier operation. (Refer to Section V.)

3-71. REMOVAL OF ATTITUDE GYRO. (PA-32-260, PA-32-300, PA-32R-300, PA-32RT-300, PA-32RT-300T, PA-32-301, PA-32-301T, PA-32R-301 and PA-32R-301T)

The attitude gyro is located in the left instrument panel.

- a. Remove the face panel by removing the screws from around the perimeter of the panel.
- b. Disconnect the electrical connector from the instrument.
- c. Disconnect the vacuum line and the relief line from the instrument. Identify hose to facilitate reinstallation. To prevent contamination, place protective covers over the ends of the hoses and the instrument ports.
- d. Remove the screws securing the instrument to the instrument panel and remove instrument.

3-72. INSTALLATION OF ATTITUDE GYRO. (PA-32-260, PA-32-300, PA-32R-300, PA-32RT-300, PA-32RT-300T, PA-32-301, PA-32-301T, PA-32R-301 and PA-32R-301T) (Refer to Figure 3-12.)

- a. Position the instrument in its proper panel cutout and secure with appropriate screws.
- b. Remove any caps which were placed over the hoses and the instrument ports.
- c. Connect hoses to proper ports of instrument.
- d. Connect the electrical connector to the instrument.
- e. Check operation of instrument. (Refer to Section V.)
- f. Install face panel and secure with appropriate screws.

3-73. REMOVAL OF DIRECTIONAL GYRO AND/OR HORIZONTAL SITUATION INDICATOR. (PA-32-260, PA-32-300, PA-32R-300, PA-32RT-300, PA-32RT-300T, PA-32-301, PA-32-301T, PA-32R-301 and PA-32R-301T)

The directional gyro is located in the left instrument panel.

- a. Remove the face panel by removing the screws from around the perimeter of the panel.
- b. Disconnect the electrical connector from the instrument.
- c. Disconnect the vacuum line and the relief line from the instrument. Identify hoses to facilitate reinstallation. To prevent contamination, place protective covers over the ends of the hoses and the instrument ports.
- d. Remove the screws securing the instrument to the instrument panel and remove instrument.

3-74. INSTALLATION OF DIRECTIONAL GYRO AND/OR HORIZONTAL SITUATION INDICATOR. (PA-32-260, PA-32-300, PA-32R-300, PA-32RT-300, PA-32RT-300T, PA-32-301, PA-32-301T, PA-32R-301 and PA-32R-301T) (Refer to Figure 3-13.)

- a. Position the instrument in its proper panel cutout and secure with appropriate screws.
- b. Remove any caps which were placed over the hoses and the instrument ports.
- c. Connect hoses to proper ports of instrument.
- d. Connect the electrical connector to the instrument.
- e. Check operation of instrument. (Refer to Section V.)
- f. Install face panel and secure with appropriate screws.

3-75. REMOVAL OF ALTITUDE HOLD UNIT. (PA-32-260, PA-32-300, PA-32R-300, PA-32RT-300, PA-32RT-300T, PA-32-301, PA-32-301T, PA-32R-301 and PA-32R-301T)

The altitude hold unit is located behind the right instrument panel directly forward of the circuit breaker panel. The unit is secured to a mounting bracket with strap clamps which in turn is shock mounted to the airplane.

- a. Access to the unit is from beneath the right instrument panel.
- b. Disconnect the electrical connector from the altitude hold unit.
- c. Disconnect the static hose by releasing the clamp and sliding the hose off the port. To prevent contamination, place protective covers over the end of the hose and the instrument port.
- d. Loosen the clamp screws securing the unit to the mounting bracket.
- e. Remove the altitude hold unit from the airplane.

3-76. INSTALLATION OF ALTITUDE HOLD UNIT. (PA-32-260, PA-32-300, PA-32R-300, PA-32RT-300, PA-32RT-300T, PA-32-301, PA-32-301T, PA-32R-301 and PA-32R-301T) (Refer to Figure 3-14 for 1C407 or Figure 3-33 for 1C725)

- a. Position the altitude hold unit on the mounting bracket located behind the right instrument panel directly forward of the circuit breaker panel. Position unit on bracket and secure by tightening clamp screws to 5 ± 1 inch pounds.
- b. Remove any caps which were placed over the ends of the hose and the instrument port.
- c. Connect the hose from the rate of climb indicator to the port marked static on the unit and secure with clamp.
- d. Connect the electrical connector to the unit.
- e. Check operation of altitude hold unit. (Refer to Section V.)

3-77. REMOVAL OF RELAY BOX. (PA-32-260, S/N 32-7500001 to 7700023; PA-32-300, S/N 32-7540001 to 7840045 and PA-32R-300, S/N 32R-7680001 to 7780417)

The relay box is located behind the right instrument panel just to the left of the circuit breaker panel.

- a. Access to the relay box is from beneath the right instrument panel.
- b. Disconnect the electrical connector from the relay box.
- c. Remove the screws securing the relay box to the instrument panel.
- d. Remove the relay box from the airplane.

3-78. INSTALLATION OF RELAY BOX. (PA-32-260, S/N 32-7500001 to 7700023; PA-32-300, S/N 32-7540001 to 7840045 and PA-32R-300, S/N 32R-7680001 to 7780417) (Refer to Figure 3-14.)

- a. Position the relay box on the back side of the right instrument panel just to the left of the circuit breaker panel and secure with appropriate screws.
- b. Connect the electrical connector to the relay box.
- c. Check operation of relay box. (Refer to Section V.)

3-79. REMOVAL OF RELAY BOX. (PA-32-260, S/N 32-7800001 and up; PA-32-300, S/N 32-7840046 and up; PA-32R-300, S/N 32R-7780418 and up; PA-32RT-300, PA-32RT-300T, PA-32-301, PA-32-301T, PA-32R-301 and PA-32R-301T)

The relay box is located behind the left instrument panel along the left side of the fuselage.

- a. Access to the relay box is from beneath the left instrument panel.
- b. Disconnect the electrical connector from the relay box.
- c. Remove the screws securing the relay box to its mount.
- d. Remove relay box from the airplane.

3-80. INSTALLATION OF RELAY BOX. (PA-32-260, S/N 32-7800001 and up; PA-32-300, S/N 32-7840046 and up; PA-32R-300, S/N 32R-7780418 and up; PA-32RT-300; PA-32RT-300T; PA-32-301; PA-32-301T; PA-32R-301 and PA-32R-301T) (Refer to Figure 3-14.)

- a. Position the relay box behind the left instrument panel along the left side of the fuselage and secure with appropriate screws.
- b. Connect the electrical connector to the relay box.
- c. Check operation of relay box. (Refer to Section V.)

3-81. REMOVAL OF ROLL SERVO. (PA-32-260, PA-32-300, PA-32R-300, PA-32RT-300, PA-32RT-300T, PA-32-301, PA-32-301T, PA-32R-301 and PA-32R-301T)

The roll servo is located beneath the floor panel under the center set of seats.

- a. Remove the center seats and floor panel directly behind the main spar by removing the seat belts and screws. Remove the floor panel from the airplane.
- b. Disconnect the electrical connector from the servo.
- c. Paint the aileron balance cable where the bridle cable clamps are located and then remove the two bridle cable clamps. (DO NOT paint the bridle cable end terminals as one terminal is painted red to facilitate reinstallation.)
- d. Remove the bolts, washers and nuts that secure the roll servo to the mounting bracket.
- e. Remove the roll servo from the airplane.

3-82. INSTALLATION OF ROLL SERVO. (PA-32-260, PA-32-300, PA-32R-300, PA-32RT-300, PA-32RT-300T, PA-32-301, PA-32-301T, PA-32R-301 and PA-32R-301T) (Refer to Figure 3-27.)

- a. Insert bridle cable pin in capstan and tighten bridle cable pin lock screw.
- b. Wrap the bridle cable one full turn each direction around the capstan from the bridle cable pin.
- c. Adjust the cable guards on the servo to provide a gap of .031 of an inch between the cable and guard.
- d. Position the servo on the mounting bracket located in the area beneath the floor aft of the main spar. Secure the servo with the bolts, washers and nuts previously removed.
- e. REFER TO FIGURE 3-8 AND CHECK THAT THE CONTROL CABLE TENSION (z) IS ADJUSTED TO 40 ± 5 POUNDS, PRIOR TO ATTACHING THE BRIDLE CABLE CLAMPS. Ascertain area on cable where clamp attaches is clean, dry and free of all lubricants and anti-corrosive additives. Attach the bridle cable to the aileron balance cable. The bridle cable is drawn to the balance cable and attached with clamps at the previously painted locations on the balance cable. The longest portion of the bridle cable, or the end with the red ball, extends outboard toward the left side of the airplane. (Refer to Figure 3-27.) (Should the balance cable not be painted, position the control wheel in neutral and align the bridle cable pin, installed in the capstan, as shown in Figure 3-27.) Adjust the bridle cable clamps so the bridle cable tension (y) is equal to the

control cable tension between the bridle cable clamps (x) as shown in Figure 3-8, without increasing the control cable tension from the bridle cable clamps outward. At no time shall the bridle cable tension be greater than the control cable tension between the clamps. Adjusting the bridle cable tension will lower the control cable tension between the two bridle cable clamps. Torque the bridle cable clamp bolts to 55 ± 5 inch pounds.

- f. Connect the electrical connector to the servo.

CAUTION

Check security of bridle cable clamps and the bridle cable capstan pin. To do this, turn on the master switch and with the roll command knob centered, place the roll engage rocker switch in the ON position to engage the roll servo. Turn the control wheel manually to the extreme left and right positions to ascertain the clamps and pin do not change position. Next operate the servo electrically by rotating the roll command knob to its extreme left and right position. Examine the bridle cable to verify the clamps and pin do not change position. The clutch will slip during these operations.

- g. Install the floor panel, seat belts and seat.

INTENTIONALLY LEFT BLANK

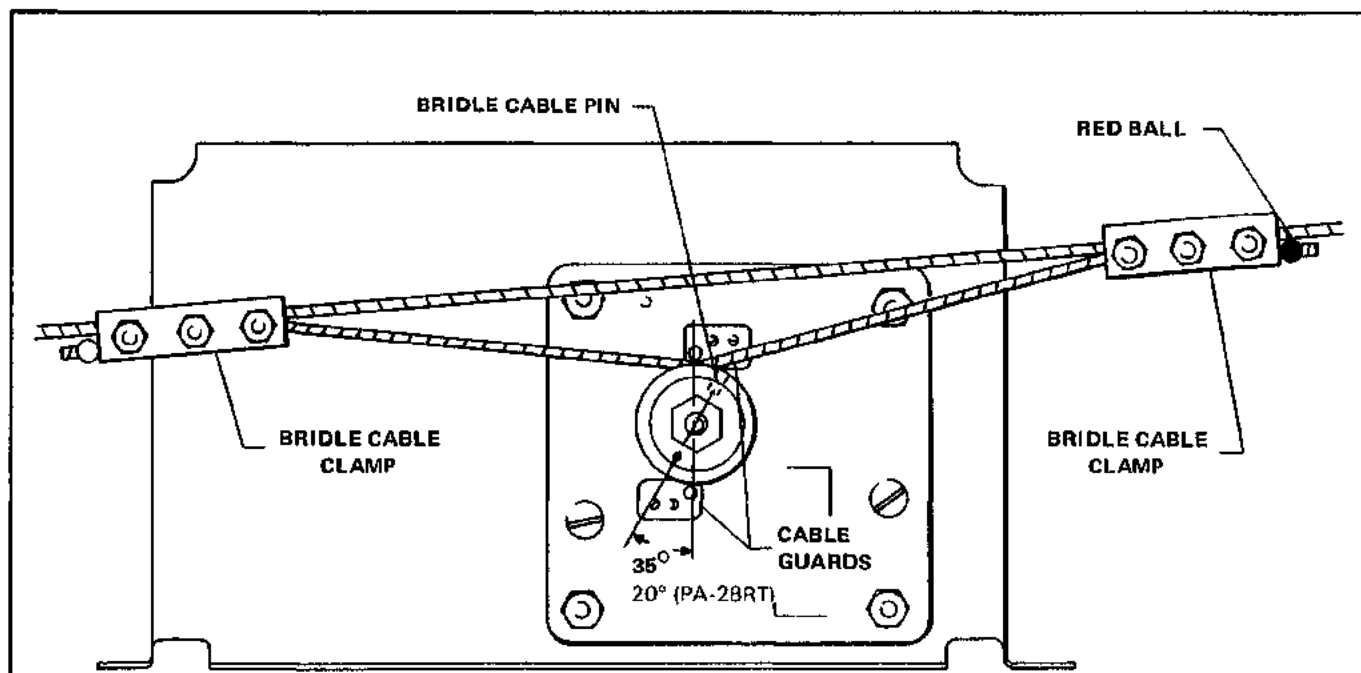

PA-32-260, PA-32-300, PA-32-301, PA-32-301T, PA-28RT-201 and PA-28RT-201T

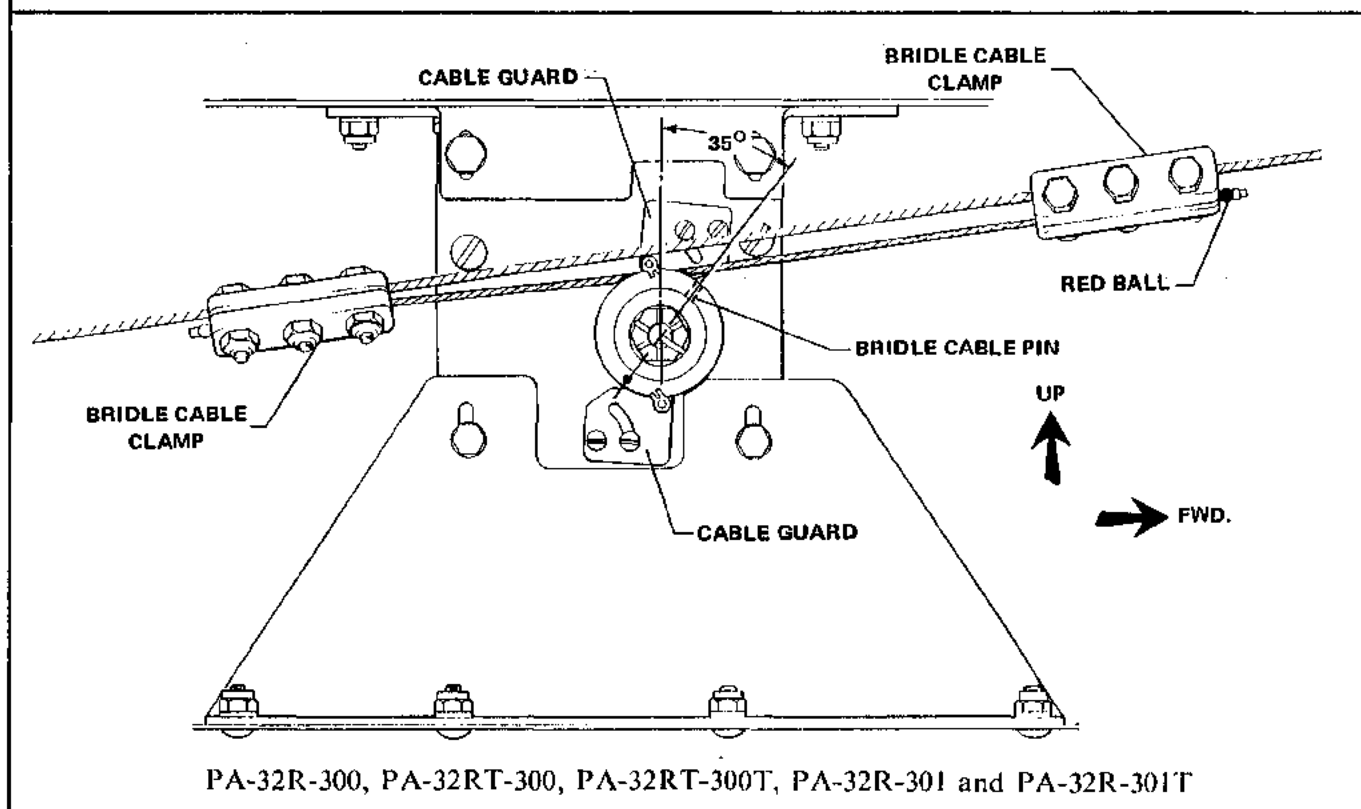

PA-32R-300, PA-32RT-300, PA-32RT-300T, PA-32R-301 and PA-32R-301T

Figure 3-27. Roli Servo Installation

3-83. REMOVAL OF PITCH SERVO. (PA-32-260 and PA-32-300, S/N 32-7540001 to 7840222)

The pitch servo is located beneath the floor panel under the center set of seats.

- a. Remove the center seats and floor panel directly behind the main spar by removing the seat belts and screws.
- b. Disconnect the electrical connector from the servo.
- c. Paint the stabilator control cable where the bridle cable clamps are located and then remove the two bridle cable clamps. (DO NOT paint the bridle cable end terminals as one terminal is painted red to facilitate reinstallation.)
- d. Remove the four bolts, washers and nuts securing the pitch servo to the mounting bracket.
- e. Remove the pitch servo from the airplane.

3-84. REMOVAL OF PITCH SERVO. (PA-32-300, S/N 32-7940001 and up; PA-32R-300, PA-32RT-300, PA-32RT-300T, PA-32-301, PA-32-301T, PA-32R-301 and PA-32R-301T)

The pitch servo is located aft of the rear baggage compartment on the lower fuselage.

- a. Access to the servo is through the rear baggage area.
- b. Remove the attaching screws in aft panel of rear baggage compartment and remove panel.
- c. Disconnect the electrical connector from the servo.
- d. Paint the stabilator control cables where the bridle cable clamps are located and then remove the two bridle cable clamps. (DO NOT paint the bridle cable end terminals as one terminal is painted red to facilitate reinstallation.)
- e. Remove the bolts, washers and nuts securing the servo to the mounting brackets and remove the servo from the airplane.

3-85. INSTALLATION OF PITCH SERVO. (PA-32-260 and PA-32-300, S/N 32-7540001 to 7840222)
(Refer to Figure 3-28.)

- a. Insert bridle cable pin in capstan and tighten bridle cable pin lock screw.
- b. Wrap the bridle cable one-half turn each direction around the capstan from the bridle cable pin.
- c. Adjust the cable guard on the servo to provide a gap of .031 of an inch between the capstan and guard.
- d. Position the pitch servo on the mounting bracket located in the area beneath the floor aft of the main spar and secure with bolts, washers and nuts previously removed.
- e. REFER TO FIGURE 3-9 AND CHECK THAT THE CONTROL CABLE TENSION (z) IS ADJUSTED TO 40 ± 5 POUNDS PRIOR TO ATTACHING THE BRIDLE CABLE CLAMPS. Ascertain area on cable where clamp attaches is clean, dry and free of all lubricants and anti-corrosive additives. Attach the bridle cable to the stabilator control cable. The bridle cable is drawn to the right stabilator control cable and attach with clamps at the previously painted locations on the control cable. The longest portion of the bridle cable or the end with the red ball extends aft. (Refer to Figure 3-28.) (Should the balance cable not be painted, position the control wheel full forward and with the servo disengaged, position the capstan pulley so that the bridle cable pin is aligned as shown in Figure 3-28.) Adjust the bridle cable clamps so the cable tension (y) is equal to the control cable tension between the bridle cable clamps (x) without increasing the control cable tension from the bridle cable clamps outward. At no time shall the bridle cable tension be greater than the control cable tension between the clamps. Adjusting the bridle cable tension will lower the control cable tension between the two bridle cable clamps. Torque the bridle cable clamp bolts to 55 ± 5 inch pounds.
- f. Connect the electrical connection to the servo.

CAUTION

Check security of bridle cable clamps and the bridle cable capstan pin. To do this, turn on the master switch and with the pitch command disc centered place the roll engage rocker switch and the pitch mode switch in the ON position. Move the control wheel manually to the extreme fore and aft positions to ascertain the clamps and pin do not change position. Next operate the servo electrically by rotating the pitch command disc full up and full down. Examine the bridle cable to verify the clamps and pin do not change position. The clutch will slip during these operations.

- g. Install the floor panel, seat belts and seats.

3-86. INSTALLATION OF PITCH SERVO. (PA-32-300, S/N 32-7940001 and up; PA-32R-300; PA-32RT-300; PA-32RT-300T; PA-32-301; PA-32-301T; PA-32R-301 and PA-32R-301T) (Refer to Figure 3-28.)

- a. Install bridle cable pin in capstan with the longest portion of the bridle cable or the end with the red terminal down and tighten bridle cable pin lock screw.

- b. Wrap the end of the bridle cable with the red terminal one-half turn counterclockwise from the bridle cable pin on the upper capstan grooves and the other end of the bridle cable three-quarters of a turn clockwise from the bridle cable pin on the lower capstan grooves.

- c. Adjust the cable guards on the servo to provide a gap of .031 of an inch between the capstan and guard.

- d. Position the pitch servo on the mounting brackets located on the lower fuselage aft of the rear baggage area and secure with bolts, washers and nuts previously removed.

- e. REFER TO FIGURE 3-9 AND CHECK THAT THE CONTROL CABLE TENSION (Z) IS ADJUSTED TO 40 ± 5 POUNDS PRIOR TO ATTACHING THE BRIDLE CABLE CLAMPS. Ascertain area on cable where clamp attaches is clean, dry and free of all lubricants and anti-corrosive additives. Attach the bridle cable to the stabilator control cable. The bridle cable is drawn to the right stabilator control cable and attached with clamps at the previously painted locations on the control cable. The longest portion of the bridle cable or the end with the red ball extends aft. (Refer to Figure 3-28.) (Should the balance cable not be painted, position the control wheel full forward and with the servo disengaged, position the capstan pulley so that the bridle cable pin is aligned as shown in Figure 3-28.) Adjust the bridle cable clamps so the bridle cable tension (Y) equals $15 + 0.5$ lbs. tension between the bridle cable clamps (X) without increasing the control cable tension from the bridle cable clamps outward. At no time shall the bridle cable tension be greater than the control cable tension between the clamps. Adjusting the bridle cable tension will lower the control cable tension between the two bridle cable clamps. Torque the bridle cable clamp bolts to 55 ± 5 inch-pounds.

- f. Connect the electrical connector to the servo.

CAUTION

Check security of bridle cable clamps and the bridle cable capstan pin. To do this, turn on the master switch and with the pitch command disc centered, place the roll engage rocker switch and the pitch mode switch in the ON position. Move the control wheel manually to the extreme fore and aft positions to ascertain the clamps and pin do not change position. Next, operate the servo electrically by rotating the pitch command disc full up and full down. Examine the bridle cable to verify the clamps and pin do not change position. The clutch will slip during these operations.

- g. Install aft panel in rear baggage compartment and secure with appropriate screws.

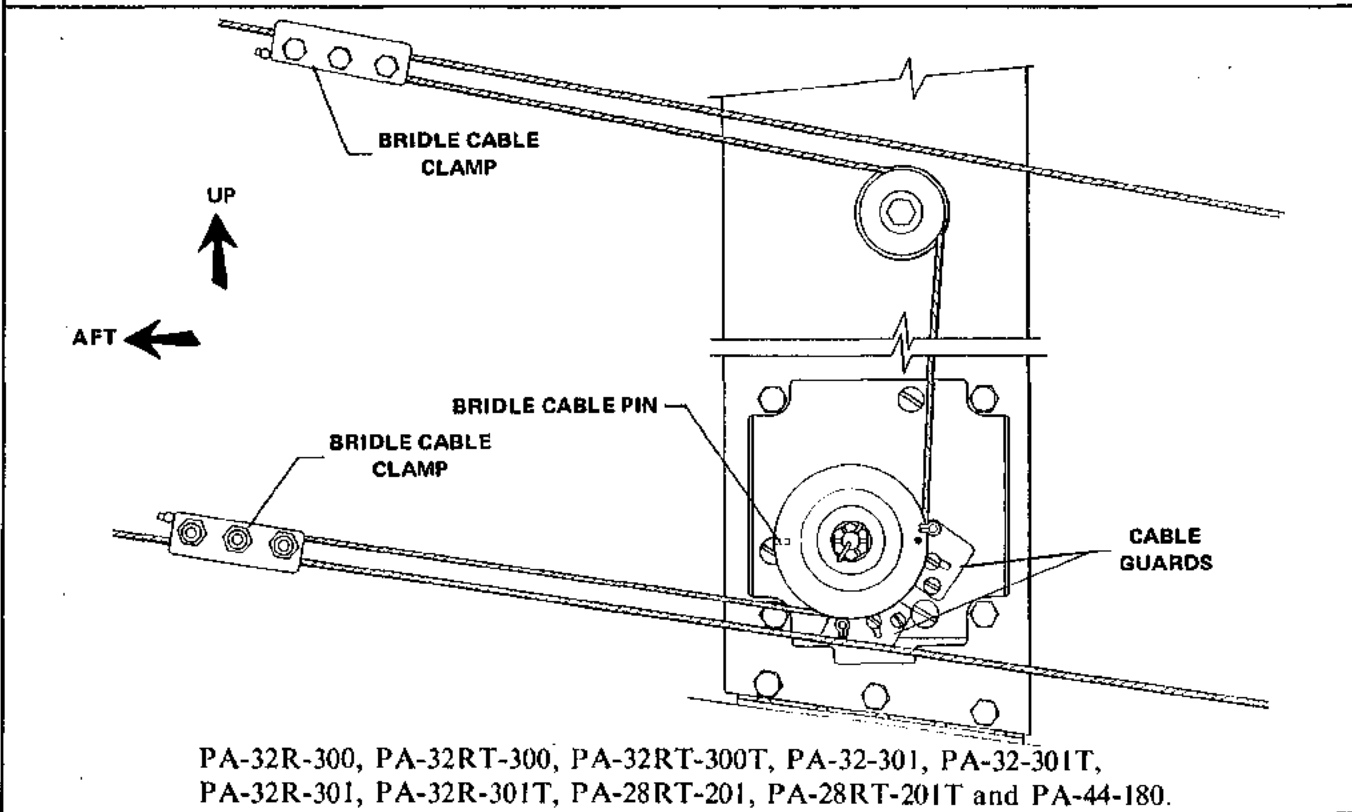
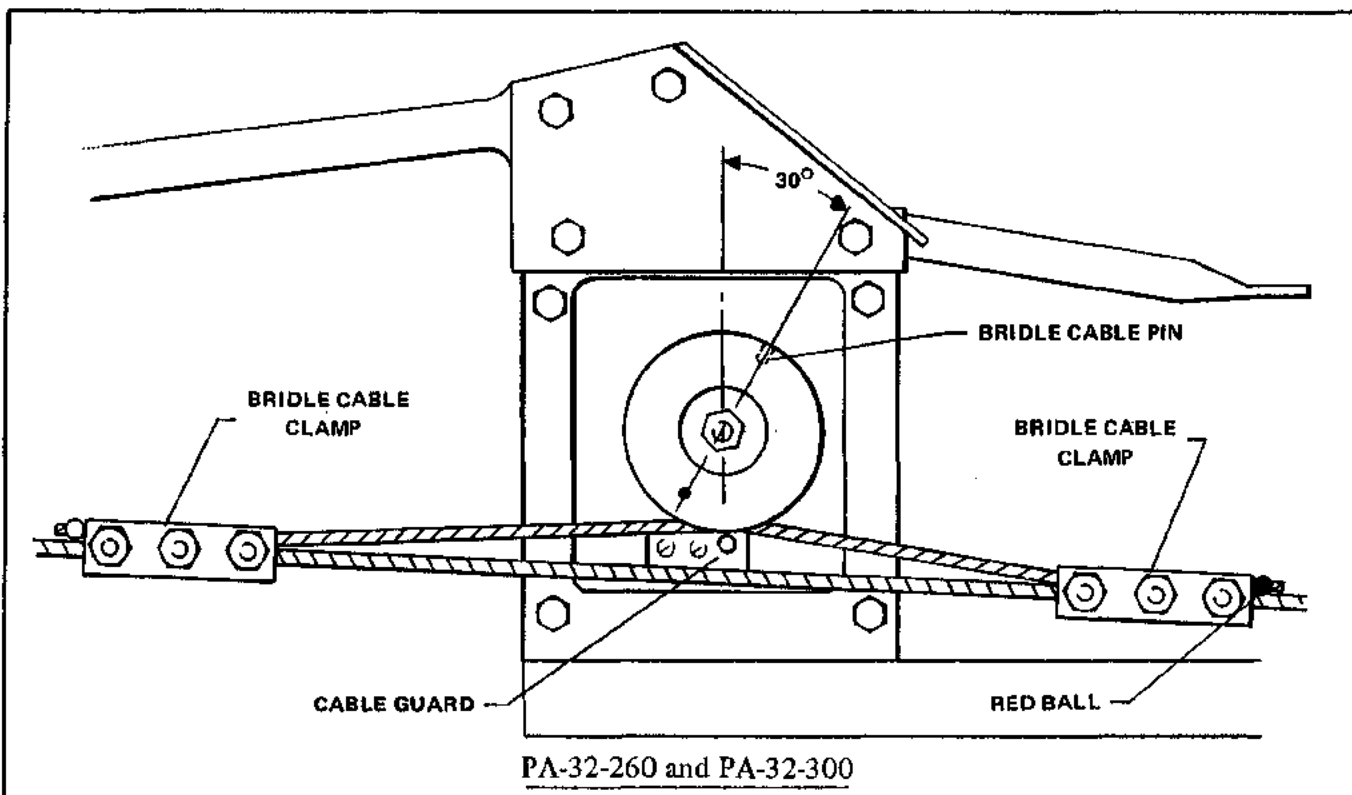

Figure 3-28. Pitch Servo Installation

3-87. REMOVAL OF PITCH TRIM SERVO. (PA-32-260, PA-32-300, PA-32R-300, PA-32RT-300, PA-32RT-300T, PA-32-301, PA-32-301T, PA-32R-301 and PA-32R-301T.)

The pitch trim servo is located aft of the rear baggage area on the lower fuselage.

- a. Access to the servo is through the rear baggage area.
- b. Remove attaching screws in aft panel of rear baggage compartment and remove panel.

NOTE

To maintain cable routing of the trim cable during removal and installation of the trim servo, it is recommended that a service aid be fabricated from shop material such as two bridle cable clamps and a short length of cable or two blocks of wood pre-drilled with a bolt and nut inserted to maintain cable routing.

- c. Loosen trim cable turnbuckles to release cable tension.
- d. Disconnect the electrical connector from the trim servo.
- e. Remove the four mounting bolts securing the trim servo to the mounting bracket.
- f. Unwrap the trim cable from the capstan and idler pulleys.
- g. Remove the trim servo from the airplane.

3-88. INSTALLATION OF PITCH TRIM SERVO. (PA-32-260, PA-32-300, PA-32R-300, PA-32RT-300, PA-32RT-300T, PA-32-301, PA-32-301T, PA-32R-301 and PA-32R-301T) (Refer to Figure 3-29.)

- a. Position trim servo on mounting brackets and secure with mounting bolts.
- b. Route the trim cable from the forward part of the airplane around the aft inboard idler pulley, then around the bottom capstan groove and around the aft outboard idler pulley continuing around the forward outboard idler pulley and around the top capstan groove to the forward inboard idler pulley, to the aft section of the airplane.
- c. Tighten the trim cable to obtain 10 ± 2 pounds cable tension.
- d. Connect the electrical connector to the trim servo.
- e. Check trim servo operation. (Refer to Section V.)
- f. Install aft panel in rear baggage compartment and secure with appropriate screws.

➔ **3-89. REMOVAL OF GYRO SLAVING AMPLIFIER. (PA-32-260, PA-32-300, PA-32R-300, PA-32RT-300 and PA-32RT-300T). The gyro slaving amplifier is located behind the left instrument panel on a mounting bracket above the left rudder pedal.**

- a. Access to the amplifier is from beneath the left instrument panel.
- b. Disconnect the electrical connection from the amplifier.
- c. Remove the screws securing the amplifier to the mounting bracket.
- d. Remove the amplifier from the airplane.

➔ **3-90. INSTALLATION OF GYRO SLAVING AMPLIFIER. (PA-32-260, PA-32-300, PA-32R-300, PA-32RT-300 and PA-32RT-300T) (Refer to Figure 3-19.)**

- a. Position the amplifier on the mounting bracket located behind the left instrument panel and secure with appropriate screws.
- b. Connect the electrical connection to the amplifier.
- c. Check amplifier operation. (Refer to Section V.)

- ➔ **3-91. REMOVAL OF FLUX DETECTOR.** (PA-32-260, PA-32-300, PA-32RT-300 and PA-32RT-300T).
The flux detector is located aft of the rear baggage area on a mounting bracket on the right side of the fuselage.
- Access to the flux detector is through the rear baggage area.
 - Remove the access plate in lower right side of aft panel in the rear baggage area by turning the screw type fasteners to release the access plate.
 - Disconnect the electrical connection from the flux detector.
 - Mark the original position of the flux detector.
 - Remove the three screws securing the flux detector to the mounting bracket.
 - Remove the flux detector from the airplane.
- ➔ **3-92. INSTALLATION OF FLUX DETECTOR.** (PA-32-260, PA-32-300, PA-32R-300, PA-32RT-300 and PA-32RT-300T) (Refer to Figure 3-20.)
- Position the flux detector on the mounting bracket with the label side up and the arrow pointing forward, and secure with original screws.
 - Connect the electrical connection to the flux detector.
 - Check flux detector operation. (Refer to Section V.)
 - Install access plate in lower right side of aft panel in the rear baggage area and turn screw type fasteners to secure access plate.
- ➔ **3-93. REMOVAL OF NAV CONVERTER (1C707)** (PA-32-260, PA-32-300, PA-32R-300, PA-32RT-300 and PA-32RT-300T)
The NAV Converter is located on a mounting tray under the left side of the instrument panel directly forward of the console.
- Access to the converter is from beneath the left instrument panel.
 - Disconnect the electrical connection from the NAV Converter.
 - Remove the three screws and nuts securing the NAV Converter to the mounting tray.
 - Remove the NAV Converter from the airplane.
- ➔ **3-94. INSTALLATION OF NAV CONVERTER (1C707)** (PA-32-260, PA-32-300, PA-32R-300, PA-32RT-300 and PA-32RT-300T) (Refer to Figure 3-21.)
- Place the NAV Converter on the mounting tray behind the left instrument panel directly forward of the console and secure with appropriate screws and nuts.
 - Connect the electrical connection to the NAV Converter.
 - Check NAV Converter operation. (Refer to Section V.)

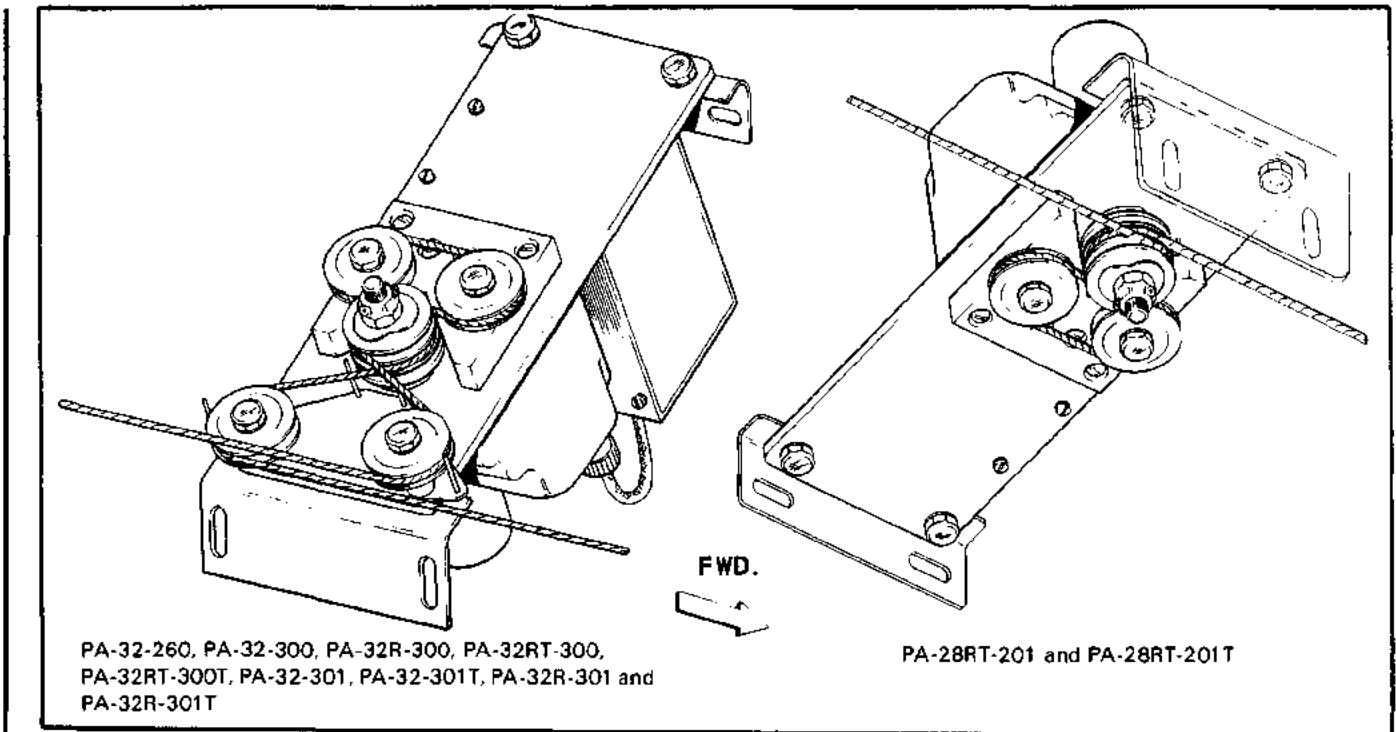

Figure 3-29. Pitch Trim Servo Installation,

3-95. REMOVAL OF CONSOLE. (PA-34-200T)

The console is located in the lower left side of the instrument panel.

- a. Remove the roll command knob.
- b. Remove the four screws securing the face plate and remove face plate.
- c. Remove the console retaining screw. It is the screw located to the left of the trim meter on the console.
- d. Disconnect the electrical harness plugs CD-20 and CD-40 from the rear of the console.
- e. Remove the console from the airplane.

3-96. INSTALLATION OF CONSOLE. (PA-34-200T) (Refer to Figure 3-10.)

- a. Place the console in the instrument panel cutout.
- b. Connect the electrical harness plugs, CD-20 and CD-40, to the rear of the console. (Make sure spring clip on CD-20 is secure.)
- c. Secure the console and install and secure the face plate.
- d. Install roll command knob and secure.
- e. Check console operation. (Refer to Section V.)

3-97. REMOVAL OF AUTOPILOT AMPLIFIER. (PA-34-200T)

The autopilot amplifier is located on the right side of the bulkhead aft of the main spar beneath the floor panel under the right seat.

- a. Remove the center seats from the airplane.
- b. Remove the floor panel directly behind the main spar by removing the seat belts and screws. Remove the floor panel from the airplane.
- c. Disconnect the electrical harness from the amplifier by removing the two knurled screws from the large amplifier connector and removing the connector from the amplifier.
- d. Unfasten the two fasteners that secure the amplifier to the mounting bracket and remove the amplifier from the airplane.

THIS PAGE INTENTIONALLY LEFT BLANK

3-98. INSTALLATION OF AUTOPILOT AMPLIFIER. (PA-34-200T) (Refer to Figure 3-11.)

- a. With the large thirty pin receptacle pointing inboard, place the amplifier on the mounting bracket located on the bulkhead aft of the main spar and secure with fasteners.
- b. With the cables from the harness fanning upward, connect the harness to the amplifier by securing with the two screws previously removed from the receptacle.
- c. Check amplifier operation. (Refer to Section V.)
- d. Install the floor panel, seat belts and seats.

3-99. REMOVAL OF ELECTRONIC TRIM AMPLIFIER. (PA-34-200T)

The electronic trim amplifier is located on a mounting bracket in the center of the fuselage beneath the floor panel directly aft of the main spar.

- a. Remove the center seats from the airplane.
- b. Remove the floor panel directly behind the main spar by removing the seat belts and screws. Remove the floor panel from the airplane.
- c. Disconnect the electrical connections from the amplifier.
- d. Remove the screws securing the amplifier to the mounting bracket.
- e. Remove the amplifier from the airplane.

3-100. INSTALLATION OF ELECTRONIC TRIM AMPLIFIER. (PA-34-200T) (Refer to Figure 3-11.)

- a. Place the electronic trim amplifier on the mounting bracket with the CD-16 connectors pointing aft and secure with appropriate screws.
- b. Connect the electrical connections to the amplifier.
- c. Check amplifier operation. (Refer to Section V.)
- d. Install the floor panel, seat belts and seats.

3-101. REMOVAL OF ATTITUDE GYRO. (PA-34-200T)

The attitude gyro is located in the left instrument panel.

- a. Remove the face panel by removing the screws from around the perimeter of the panel.
- b. Disconnect the electrical connection from the instrument.
- c. Disconnect the vacuum line and the relief line from the instrument. Identify hoses to facilitate reinstallation. To prevent contamination, place protective covers over the ends of the hoses and the instrument ports.
- d. Remove the screws securing the instrument to the instrument panel and remove instrument.

3-102. INSTALLATION OF ATTITUDE GYRO. (PA-34-200T) (Refer to Figure 3-12.)

- a. Position the instrument in its proper panel cutout and secure with appropriate screws.
- b. Remove any caps which were placed over the hoses and the instrument ports.
- c. Connect hoses to proper ports of instrument.
- d. Connect the electrical connection to the instrument.
- e. Check operation of instrument. (Refer to Section V.)
- f. Install face panel and secure with appropriate screws.

3-103. REMOVAL OF DIRECTIONAL GYRO AND/OR HORIZONTAL SITUATION INDICATOR. (PA-34-200T)

The Directional Gyro and/or Horizontal Situation Indicator is located in the left instrument panel.

- a. Remove the face panel by removing the screws from around the perimeter of the panel.
- b. Disconnect the electrical connection from the instrument.
- c. Disconnect the vacuum line and the relief line from the instrument. Identify hoses to facilitate reinstallation. To prevent contamination, place protective covers over the ends of the hoses and the instrument ports.
- d. Remove the screws securing the instrument to the instrument panel and remove the instrument.

3-104. INSTALLATION OF DIRECTIONAL GYRO AND/OR HORIZONTAL SITUATION INDICATOR. (PA-34-200T) (Refer to Figure 3-13.)

- a. Position the instrument in its proper panel cutout and secure with appropriate screws.
- b. Remove any caps which were placed over the hoses and the instrument ports.
- c. Connect hoses to proper ports of instrument.
- d. Connect the electrical connection to the instrument.
- e. Check operation of instrument. (Refer to Section V.)
- f. Install face panel and secure with appropriate screws.

3-105. REMOVAL OF ALTITUDE HOLD UNIT. (PA-34-200T, Serial Nos. 34-7570001 to 34-7770185 incl., 34-7770187 to 34-7770263 incl.)

The altitude hold unit is located behind the left instrument panel directly forward of the console. The unit is secured to a mounting bracket with strap clamps which in turn is shock mounted to the fuselage.

- a. Access to the unit is from beneath the left instrument panel.
- b. Disconnect the electrical connection from the altitude hold unit.
- c. Disconnect the static hose by releasing the clamp and sliding the hose off the port. To prevent contamination, place protective covers over the end of the hose and the instrument port.
- d. Loosen the clamp screws securing the unit to the mounting bracket.
- e. Remove the altitude hold unit from the airplane.

3-106. INSTALLATION OF ALTITUDE HOLD UNIT. (PA-34-200T, Serial Nos. 34-7570001 to 34-7770185 incl., 34-7770187 to 34-7770263 incl.) (Refer to Figure 3-14.)

- a. Position the altitude hold unit on the mounting bracket located behind the left instrument panel directly forward of the console. Position unit so static port is pointing inboard and tighten clamp screws to 5 ± 1 inch-pounds.
- b. Remove any caps which were placed over the ends of the hose and the static port.
- c. Connect the hose from the rate of climb indicator to the port marked static on the unit and secure with clamp.
- d. Connect the electrical connection to the unit.
- e. Check operation of altitude hold unit. (Refer to Section V.)

3-107. REMOVAL OF ALTITUDE HOLD UNIT. (PA-34-200T, Serial Nos. 34-7770186, 34-7770264 and up.)

The altitude hold unit is located behind the right instrument panel directly forward of the circuit breaker panel. The unit is complete with its own mounting bracket and shock mounts which in turn are secured to a frame mounted bracket.

- a. Access to the unit is from beneath the right instrument panel.
- b. Disconnect the electrical connector from the altitude hold unit.
- c. Disconnect the static hose by releasing the clamp and sliding the hose off the port. To prevent contamination, place protective covers over the end of the hose and the instrument port.
- d. Loosen the clamp screws securing the unit to the mounting bracket.
- e. Remove the altitude hold unit from the airplane.

3-108. INSTALLATION OF ALTITUDE HOLD UNIT. (PA-34-200T, Serial Nos. 34-7770186, 34-7770264 and up.) (Refer to Figure 3-33.)

- a. Position the altitude hold unit on the mounting bracket located behind the right instrument panel directly forward of the circuit breaker panel. Position the unit so the static port is pointing outward and secure by tightening clamp screws to 5 ± 1 inch pounds.
- b. Remove any caps which were placed over the ends of the hose and the instrument port.
- c. Connect the hose from the rate of climb indicator to the port marked static on the unit and secure with clamp.

- d. Connect the electrical connector to the unit.
- e. Check operation of altitude hold unit. (Refer to Section V.)

3-109. REMOVAL OF RELAY BOX. (PA-34-200T)

The relay box is located on a mounting bracket located behind the left instrument panel directly forward of the console.

- a. Access to the relay box is from beneath the left instrument panel.
- b. Disconnect the electrical connection from the relay box.
- c. Remove the screws securing the relay box to the mounting bracket.
- d. Remove the relay box from the airplane.

3-110. INSTALLATION OF RELAY BOX. (PA-34-200T) (Refer to Figure 3-14.)

- a. Position the relay box on the mounting bracket located behind the left instrument panel directly forward of the console. With electrical connector pointing aft, secure relay box with appropriate screws.
- b. Connect the electrical connection to the relay box.
- c. Check operation of relay box. (Refer to Section V.)

3-111. REMOVAL OF ROLL SERVO. (PA-34-200T)

The roll servo is located beneath the floor panel under the center set of seats on the left side of the fuselage.

- a. Remove the center seats from the airplane.
- b. Remove the floor panel directly behind the main spar by removing seat belts and screws securing the panel. Remove the floor panel from the airplane.
- c. Disconnect the electrical connection from the servo.
- d. Paint the aileron balance cable where the bridle cable clamps are located and then remove the two bridle cable clamps. (DO NOT paint the bridle cable end terminals as one terminal is painted red to facilitate reinstallation.)
- e. Remove the bolts, washers and nuts that secure the roll servo to the mounting bracket.
- f. Remove the roll servo from the airplane.

THIS PAGE INTENTIONALLY LEFT BLANK

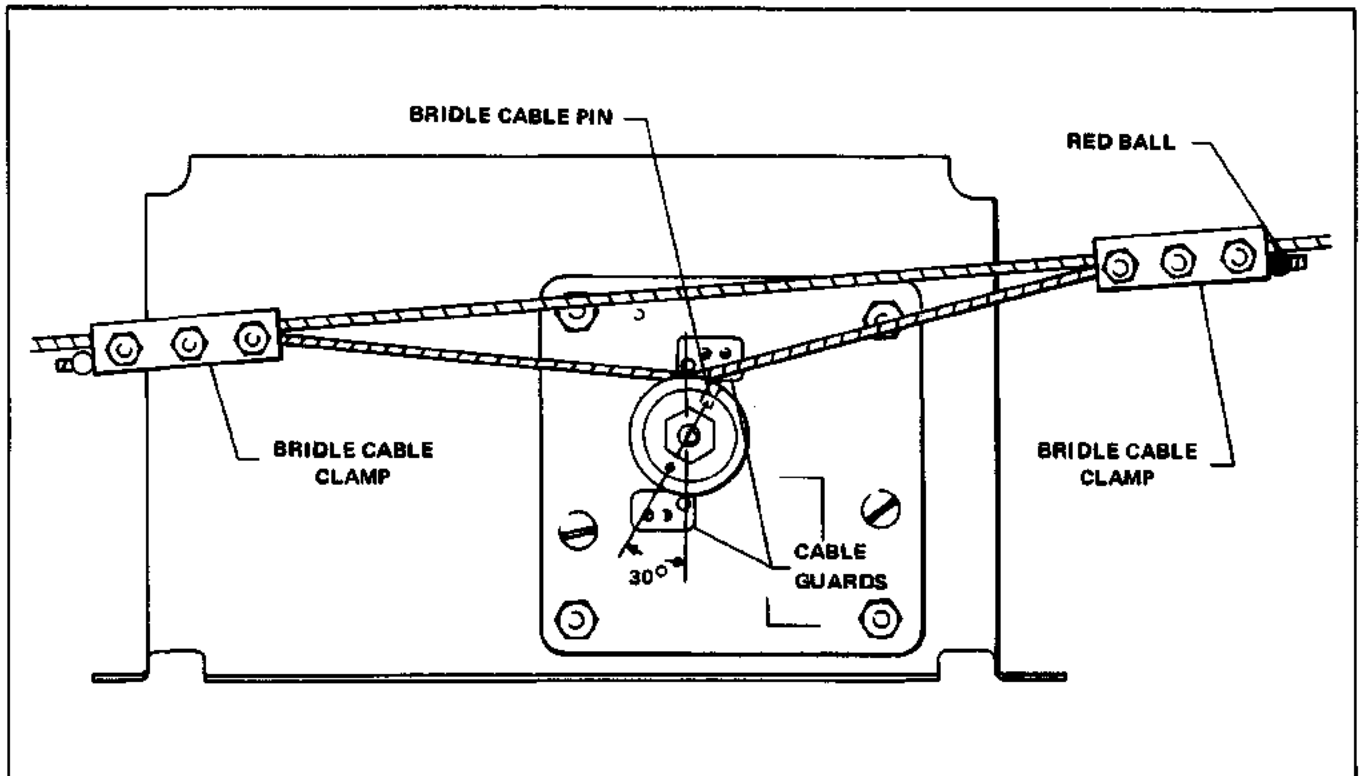

Figure 3-30. Roll Servo Installation, PA-34-200T and PA-44-180

3-112. INSTALLATION OF ROLL SERVO. (PA-34-200T) (Refer to Figure 3-30.)

- a. Install bridle cable pin in capstan and tighten bridle cable pin lock screw.
- b. Wrap the bridle cable one full turn each direction around the capstan from the bridle cable pin.
- c. Adjust the cable guards on the servo to provide a gap of .031 of an inch between the capstan and guard.
- d. Position the servo on the mounting bracket located in the area beneath the floor aft of the main spar. Secure the servo with the bolts, washers and nuts previously removed.
- e. **REFER TO FIGURE 3-8 AND CHECK THAT CONTROL CABLE TENSION (Z) IS ADJUSTED TO 40 + 5 - 0 POUNDS PRIOR TO ATTACHING THE BRIDLE CABLE CLAMPS.** Ascertain area on cable where clamps attaches is clean, dry and free of all lubricants and anti-corrosive additives. Attach the bridle cable to the aileron balance cable. The bridle cable is drawn to the balance cable and attached with clamps at the previously painted locations on the balance cable. The longest portion of the bridle cable or the end with the red ball extends outboard toward the left side of the airplane. (Refer to Figure 3-30.) (Should the balance cable not be painted, position the control wheel in neutral and align the bridle cable pin, installed in the capstan, as shown in Figure 3-30.) Adjust the bridle cable clamps so the bridle cable tension (Y) is equal to the control cable tension +0 - 15% between the bridle cable clamps (X) as shown in Figure 3-8 without increasing the control cable tension from the bridle cable clamps outward. At no time shall the bridle cable tension be greater than the control cable tension between the two bridle cable clamps. Adjusting the bridle cable tension will lower the control cable tension between the two bridle cable clamps. Torque the bridle cable clamp bolts to 55 ± 5 inch-pounds.
- f. Connect the electrical connection to the servo.

CAUTION

Check security of bridle cable clamps and the bridle cable pin. To do this, turn on the master switch and with the roll command knob centered place the roll engage rocker switch in the ON position to engage the roll servo. Turn the control wheel manually to the extreme left and right positions to ascertain the clamps and pin do not change position. Next operate the servo electrically by rotating the roll command knob to its extreme left and right position. Examine the bridle cable to verify the clamps and pin do not change position. The clutch will slip during these operations.

- g. Install the floor panel, seat belts and seats.

3-113. REMOVAL OF PITCH SERVO. (PA-34-200T)

The pitch servo is located beneath the floor panel under the center set of seats.

- a. Remove the center seats from the airplane.
- b. Remove the floor panel directly behind the main spar by removing seat belts and screws securing the panel. Remove the floor panel from the airplane.
- c. Open access door in aft panel of rear baggage area and disconnect down springs.
- d. Disconnect the electrical connection from the servo.
- e. Paint the stabilator control cable where the bridle cable clamps are located and then remove the two bridle cable clamps. (DO NOT paint the bridle cable end terminals as one terminal is painted red to facilitate reinstallation.)
- f. Remove the four bolts and nuts that secure the pitch servo to the mounting bracket.
- g. Remove the pitch servo from the airplane.

3-114. INSTALLATION OF PITCH SERVO. (PA-34-200T) (Refer to Figure 3-31.)

- a. Install bridle cable pin in capstan and tighten bridle cable pin lock screw.
- b. Wrap the bridle cable one half turn each direction around the capstan from the bridle cable pin.
- c. Adjust the cable guard on the servo to provide a gap of .031 of an inch between the capstan and guard.
- d. Position the pitch servo on the mounting bracket located in the area beneath the floor aft of the main spar. Secure the servo with the bolts and nuts previously removed.
- e. REFER TO FIGURE 3-9 AND CHECK THAT THE CONTROL CABLE TENSION (Z) IS ADJUSTED TO 40 + 5 - 0 POUNDS (WITH DOWN SPRINGS DISCONNECTED) PRIOR TO ATTACHING THE BRIDLE CABLE CLAMPS. Ascertain area on cable where clamp attaches is clean, dry and free of all lubricants and anti-corrosive additives. Attach the bridle cable to the stabilator control cable. The bridle cable is drawn to the right stabilator control cable and attached with clamps at the previously painted locations on the control cable. The longest portion of the bridle cable or the end with the red ball extends aft. (Refer to Figure 3-31.) (Should the balance cable not be painted, position the control wheel full forward and with the servo disengaged, position the capstan pulley so that the bridle cable pin is aligned as shown in Figure 3-31.) Adjust the bridle cable clamps so the bridle cable tension (Y) is equal to the control cable tension +0 - 15% between the bridle cable clamps (X) as shown in Figure 3-9 without increasing the control cable tension from the bridle cable clamps outward. At no time shall the bridle cable

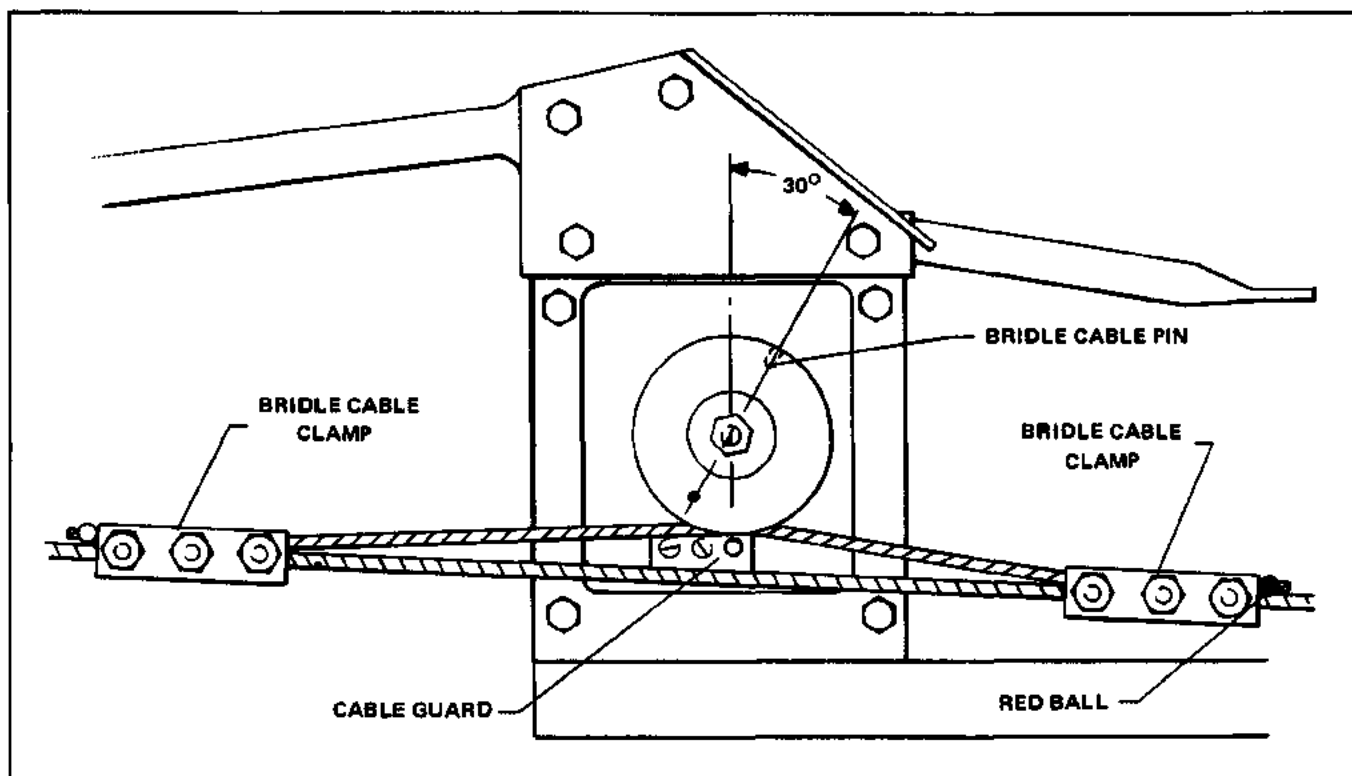

Figure 3-31. Pitch Servo Installation, PA-34-200T

tension be greater than the control cable tension between the clamps. Adjusting the bridle cable tension will lower the control cable tension between the two bridle cable clamps. Torque the bridle cable clamp bolts to 55 ± 5 inch-pounds.

- f. Connect the electrical connection to the servo.
- g. Connect down springs to control cables.

CAUTION

Check security of bridle cable clamps and the bridle cable capstan pin. To do this, turn on the master switch and with the pitch command disc centered place the roll engage rocker switch and the pitch mode switch in the ON position. Move the control wheel manually to the extreme fore and aft positions to ascertain the clamps and pin do not change position. Next operate the servo electrically by rotating the pitch command disc full up and full down. Examine the bridle cable to verify the clamps and pin do not change position. The clutch will slip during these operations.

- h. Install the floor panel, seat belts and seats.

3-115. REMOVAL OF PITCH TRIM SERVO. (PA-34-200T)

The pitch trim servo is located aft of the rear baggage area on the lower fuselage.

- a. Access to the servo is through the rear baggage area.
- b. Remove the access plate in lower right side of the aft panel in rear baggage area by turning the screw type fasteners to release the access plate.

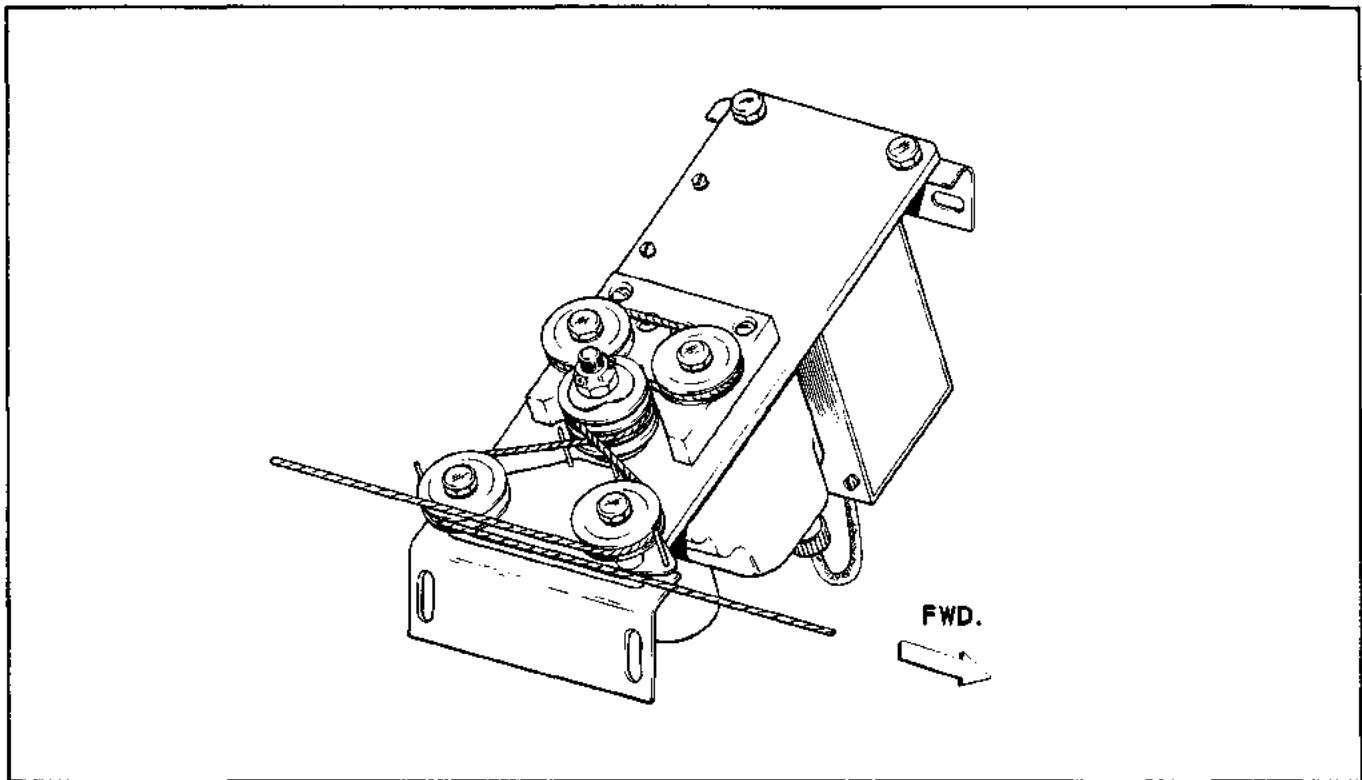

Figure 3-32. Pitch Trim Servo Installation, PA-34-200T

NOTE

To maintain cable routing of the trim cable during removal and installation of the trim servo, it is recommended that a service aid be fabricated from shop material such as two bridle cable clamps and a short length of cable or two blocks of wood pre-drilled with a bolt and nut inserted to maintain cable routing.

- c. Loosen trim cable turnbuckles to release cable tension.
- d. Disconnect the electrical connection from the trim servo.
- e. Remove the four bolts securing the trim servo to the mounting bracket.
- f. Unwrap the trim cable from the capstan and idler pulleys.
- g. Remove the trim servo from the airplane.

3-116. INSTALLATION OF PITCH TRIM SERVO. (PA-34-200T) (Refer to Figure 3-32.)

- a. Position trim servo on mounting brackets and secure with mounting bolts.
- b. Route the trim cable from the forward part of the airplane around the aft inboard idler pulley, then around the bottom capstan groove and around the aft outboard idler pulley continuing around the forward outboard idler pulley and around the top capstan groove to the forward inboard idler pulley, to the aft section of the airplane.
- c. Tighten the trim cable to obtain 10 ± 2 pounds cable tension.
- d. Connect the electrical connection to the trim servo.
- e. Check trim servo operation. (Refer to Section V.)
- f. Install access plate in lower right side of aft panel in rear baggage area and turn screw type fasteners to secure access plate.

3-117. REMOVAL OF GYRO SLAVING AMPLIFIER. (PA-34-200T)

The gyro slaving amplifier is located behind the left instrument panel on a mounting bracket above the left rudder pedal.

- a. Access to the amplifier is from beneath the left instrument panel.
- b. Disconnect the electrical connection from the amplifier.
- c. Remove the screws securing the amplifier to the mounting bracket.
- d. Remove the amplifier from the airplane.

3-118. INSTALLATION OF GYRO SLAVING AMPLIFIER. (PA-34-200T) (Refer to Figure 3-19.)

- a. Position the amplifier on the mounting bracket located behind the left instrument panel and secure with appropriate screws.
- b. Connect the electrical connection to the amplifier.
- c. Check amplifier operation. (Refer to Section V.)

3-119. REMOVAL OF FLUX DETECTOR. (PA-34-200T)

The flux detector is located aft of the rear baggage area on a mounting bracket on the right side of the fuselage.

- a. Access to the flux detector is through the rear baggage area.
- b. Remove the access plate in lower right side of aft panel in the rear baggage area by turning the screw type fasteners to release the access plate.
- c. Disconnect the electrical connection from the flux detector.
- d. Mark the original position of the flux detector.
- e. Remove the three screws securing the flux detector to the mounting bracket.
- f. Remove the flux detector from the airplane.

3-120. INSTALLATION OF FLUX DETECTOR. (PA-34-200T) (Refer to Figure 3-20.)

- a. Position the flux detector on the mounting bracket with the label side up and the arrow pointing forward, and secure with original screws.
- b. Connect the electrical connection to the flux detector.
- c. Check flux detector operation. (Refer to Section V.)
- d. Install access plate in lower right side of aft panel in the rear baggage area and turn screw type fasteners to secure access plate.

➔ **3-121. REMOVAL OF NAV CONVERTER (1C707) (PA-34-200T)**

The NAV Converter is located on a mounting tray under the left side of the instrument panel directly forward of the console.

- a. Access to the converter is from beneath the left instrument panel.
- b. Disconnect the electrical connection from the NAV Converter.
- c. Remove the three screws and nuts securing the NAV Converter to the mounting tray.
- d. Remove the NAV Converter from the airplane.

➔ **3-122. INSTALLATION OF NAV CONVERTER (1C707). (PA-34-200T) (Refer to Figure 3-21.)**

- a. Place the NAV Converter on the mounting tray behind the left instrument panel directly forward of the console and secure with appropriate screws and nuts.
- b. Connect the electrical connection to the NAV Converter.
- c. Check NAV Converter operation. (Refer to Section V.)

3-123. REMOVAL OF CONSOLE. (PA-44-180)

The console is located in the lower left side of the instrument panel.

- a. Remove the roll command knob.
- b. Remove the four screws securing the face plate and remove face plate.
- c. Remove the console retaining screw. It is the screw located to the left of the trim meter on the console.
- d. Disconnect the electrical harness plugs CD-20 and CD-40 from the rear of the console.
- e. Remove the console from the airplane.

3-124. INSTALLATION OF CONSOLE. (PA-44-180) (Refer to Figure 3-10.)

- a. Place the console in the instrument panel cutout.
- b. Connect the electrical harness plugs, CD-20 and CD-40, to the rear of the console. (Make sure spring clip on CD-20 is secure.)
- c. Secure the console and install and secure the face plate.
- d. Install roll command knob and secure.
- e. Check console operation. (Refer to Section V.)

3-125. REMOVAL OF AUTOPILOT AMPLIFIER. (PA-44-180)

The autopilot amplifier is located on the forward side of the bulkhead at STA. 47.65 on the right side of the airplane.

- a. Release the latches on the nose cone and swing it down out of the way to gain access to the amplifier.
- b. Disconnect the electrical harness from the amplifier by removing the two knurled screws from the large amplifier connector and removing the connector from the amplifier.
- c. Release the two fasteners that secure the amplifier to the mounting bracket and remove the amplifier from the airplane.

3-126. INSTALLATION OF AUTOPILOT AMPLIFIER. (PA-44-180) (Refer to Figure 3-11.)

- a. With the large thirty pin receptacle pointing downward, place the amplifier on the mounting bracket located on the right, forward side of the bulkhead at STA. 47.65 and secure with fasteners.
- b. Connect the electrical harness to the amplifier by securing with the two screws previously removed from the receptacle.
- c. Check amplifier operation. (Refer to Section V.)
- d. Swing the nose cone back to its proper position and fasten latches.

3-127. REMOVAL OF ELECTRONIC TRIM AMPLIFIER. (PA-44-180)

The electronic trim amplifier is located on a mounting bracket approximately in the center and on the forward side of the bulkhead at STA. 47.65.

- a. Release the latches on the nose cone and swing it down out of the way to gain access to the trim amplifier.
- b. Disconnect the electrical connectors from the amplifier.
- c. Remove the screws securing the amplifier to the mounting bracket.
- d. Remove the amplifier from the airplane.

3-128. INSTALLATION OF ELECTRONIC TRIM AMPLIFIER. (PA-44-180) (Refer to Figure 3-11.)

- a. Place the electronic trim amplifier on the mounting bracket with the CD-16 connector pointing outward on the co-pilot's side and secure with appropriate screws.
- b. Connect the electrical connectors to the amplifier.
- c. Check amplifier operation. (Refer to Section V.)
- d. Swing the nose cone back to its proper position and fasten latches.

3-129. REMOVAL OF ATTITUDE GYRO. (PA-44-180)

The attitude gyro is located in the left instrument panel.

- a. Remove the face panel by removing the screws from around the perimeter of the panel.
- b. Disconnect the electrical connector from the instrument.
- c. Disconnect the vacuum line and the relief line from the instrument. Identify hoses to facilitate re-installation. To prevent contamination, place protective covers over the ends of the hoses and the instrument ports.
- d. Remove the screws securing the attitude gyro to the instrument panel and remove gyro.

3-130. INSTALLATION OF ATTITUDE GYRO. (PA-44-180) (Refer to Figure 3-12.)

- a. Position the instrument in its proper panel cutout and secure with appropriate screws.
- b. Remove any caps which were placed over the hoses and instrument ports.
- c. Connect hoses to proper ports of instrument.
- d. Connect the electrical connector to the instrument.
- e. Check operation of instrument. (Refer to Section V.)
- f. Install face panel and secure with appropriate screws.

3-131. REMOVAL OF DIRECTIONAL GYRO AND/OR HORIZONTAL SITUATION INDICATOR. (PA-44-180)

The Directional Gyro and/or Horizontal Situation Indicator is located in the left instrument panel.

- a. Remove the face panel by removing the screws from around the perimeter of the panel.
- b. Disconnect the electrical connector from the instrument.
- c. Disconnect the vacuum line and the relief line from the instrument. Identify hoses to facilitate re-installation. To prevent contamination, place protective covers over the ends of the hoses and the instrument ports.
- d. Remove the screws securing the instrument to the instrument panel and remove the instrument.

3-132. INSTALLATION OF DIRECTIONAL GYRO AND/OR HORIZONTAL SITUATION INDICATOR. (PA-44-180) (Refer to Figure 3-13.)

- a. Position the instrument in its proper panel cutout and secure with appropriate screws.
- b. Remove any caps which were placed over the hoses and the instrument ports.
- c. Connect hoses to the proper ports of the instrument.
- d. Connect the electrical connector to the instrument.
- e. Check operation of instrument. (Refer to Section V.)
- f. Install the face panel and secure it with the appropriate screws.

3-133. REMOVAL OF ALTITUDE HOLD UNIT. (PA-44-180)

The altitude hold unit is located on the forward side of the bulkhead at STA. 47.65 approximately in the center.

- a. Release the latches on the nose cone and swing it down out of the way to gain access to the altitude hold unit.
- b. Disconnect the electrical connector from the unit.
- c. Disconnect the static hose by releasing the clamp and sliding the hose off of the port. To prevent contamination, place protective covers over the end of the hose and the instrument port.
- d. Loosen the clamp screws securing the unit to the mounting bracket.
- e. Remove the altitude hold unit from the airplane.

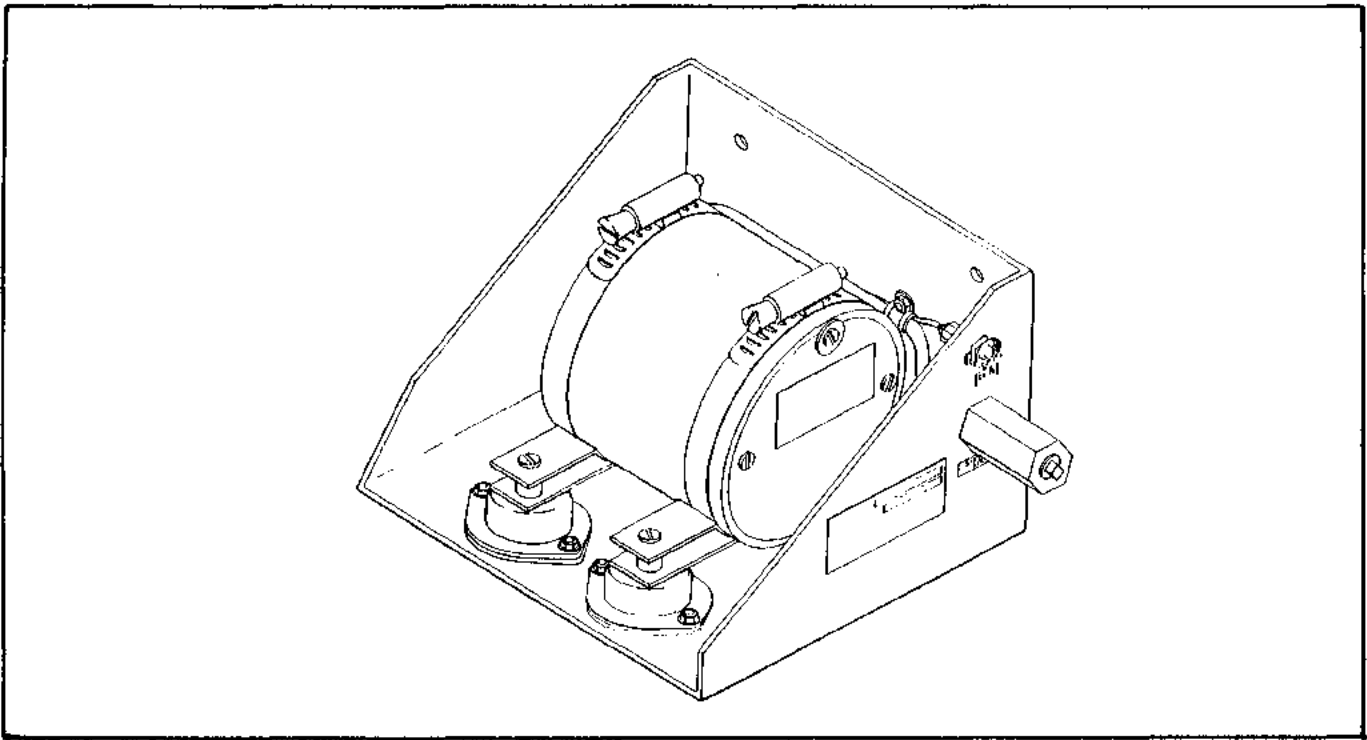

Figure 3-33. Altitude Hold Unit Installation (1C725)

3-134. INSTALLATION OF ALTITUDE HOLD UNIT. (PA-44-180) (Refer to Figure 3-33.)

- a. Position the altitude hold unit on the shock mounts so the static port is pointing toward the center of the bulkhead and tighten clamp screws to 5 ± 1 inch-pounds.
- b. Remove any caps which were placed over the ends of the hose and the static port.
- c. Connect the hose from the rate of climb indicator to the port marked static on the unit and secure with clamp.
- d. Connect the electrical connector to the unit.
- e. Check operation of altitude hold unit. (Refer to Section V.)
- f. Swing nose cone back to its proper position and fasten the latches.

3-135. REMOVAL OF RELAY BOX. (PA-44-180)

The relay box is located on the forward side of the bulkhead at STA. 47.65 on the pilot's side of the aircraft.

- a. Release the latches on the nose cone and swing it down out of the way to gain access to the relay box.
- b. Disconnect the electrical connector from the relay box.
- c. Remove the screws securing the relay box to the mounting bracket.
- d. Remove the relay box from the airplane.

3-136. INSTALLATION OF RELAY BOX. (PA-44-180) (Refer to Figure 3-34.)

- a. Position the relay box on the mounting bracket located on the forward side of the bulkhead at STA. 47.65 on the pilot's side.
- b. With the electrical connector pointing aft, secure relay box with appropriate screws.
- c. Connect the electrical connector to the relay box.
- d. Check operation of relay box. (Refer to Section V.)

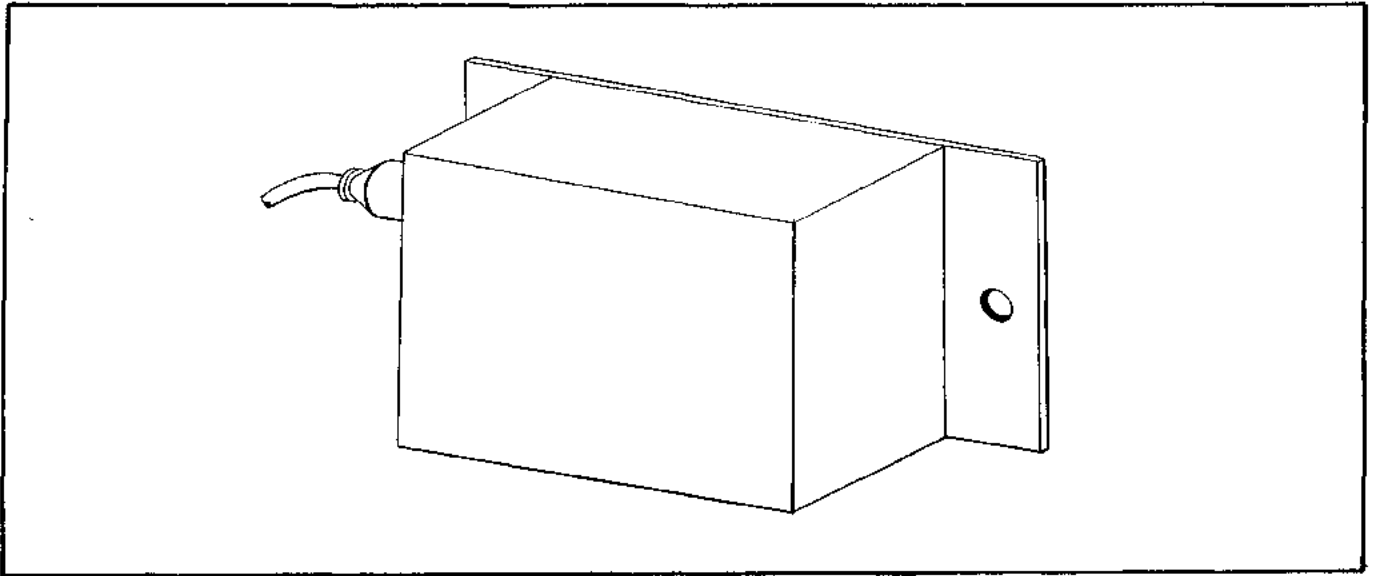

Figure 3-34. Relay Box Installation

3-137. REMOVAL OF ROLL SERVO. (PA-44-180)

The roll servo is located beneath the back seat on the pilot's side of the aircraft.

- a. Remove the third and fourth seats from the airplane.
- b. Remove the center floorboard aft of the main spar by removing seat belts and screws securing the panel. Remove the floor panel from the airplane.
- c. Disconnect the electrical connector from the roll servo.
- d. Paint the aileron balance cable where the bridle cable clamps are located and then remove the two bridle cable clamps. (DO NOT paint the bridle cable end terminals as one terminal is painted red to facilitate reinstallation.)
- e. Remove the bolts, washers and nuts that secure the roll servo to the mounting bracket.
- f. Remove the roll servo from the airplane.

3-138. INSTALLATION OF ROLL SERVO. (PA-44-180) (Refer to Figure 3-30.)

- a. Install bridle cable pin in capstan and tighten bridle cable pin lock screw.
- b. Wrap the bridle cable one full turn each direction around the capstan from the bridle cable pin.
- c. Adjust the cable guards on the servo to provide a gap of .031 of an inch between the capstan and guard.
- d. Position the servo on the mounting bracket located in the area beneath the floor aft of the main spar. Secure the servo with the bolts, washers and nuts previously removed.
- e. REFER TO FIGURE 3-7 AND CHECK THAT CONTROL CABLE TENSION (Z) IS ADJUSTED TO 40 ± 5 POUNDS PRIOR TO ATTACHING THE BRIDLE CABLE CLAMPS. Ascertain area on cable where clamps attach is clean, dry and free of all lubricants and anti-corrosive additives. Attach the bridle cable to the aileron balance cable. The bridle cable is drawn to the balance cable and attached with clamps at the previously painted locations on the balance cable. The longest portion of the bridle cable or the end with the red ball extends outboard toward the left side of the airplane. (Refer to Figure 3-30.) (Should the balance cable not be painted, position the control wheel in neutral and align the bridle cable pin, installed in the capstan, as shown in Figure 3-30.) Adjust the bridle cable clamps so the bridle cable tension (Y) is equal to the control cable tension between the bridle cable clamps (X) $+0 -20\%$, as shown in Figure 3-8. This should be done without increasing the control cable tension from the bridle cable clamps outward and without exceeding $25 +0 -5$ pounds of tension on the bridle cable. At no time shall the bridle cable tension be greater than the control cable tension between the clamps. Adjusting the bridle cable tension will lower the control cable tension between the two bridle cable clamps. Torque the bridle cable clamp bolts to 55 ± 5 inch-pounds.

- f. Connect the electrical connector to the servo.

CAUTION

Check security of bridle cable clamps and the bridle cable pin. To do this, turn on the master switch and with the roll command knob centered place the roll engage rocker switch in the ON position to engage the roll servo. Turn the control wheel manually to the extreme left and right positions to ascertain the clamps and pin do not change position. Next, operate the servo electrically by rotating the roll command knob to its extreme left and right position. Examine the bridle cable to verify the clamps and pin do not change position. The clutch will slip during these operations.

- g. Install the floor panel, seat belts and seats.

3-139. REMOVAL OF PITCH SERVO. (PA-44-180)

The pitch servo is located in the aft section of the fuselage at STA. 247.125 and in the approximate center of the aircraft.

- a. Remove the round inspection plate on the right side of the fuselage at STA. 259.7.
- b. Remove the aft baggage partition at STA. 187.8.
- c. The two piece plastic tail cone may also be removed for ease in removing the servo.
- d. Disconnect the electrical connector from the servo.
- e. Paint the stabilator control cables where the bridle cable clamps are located and then remove the two bridle cable clamps. (DO NOT paint the bridle cable end terminals as one terminal is painted red to facilitate reinstallation.)
- f. Remove the bolts, washers and nuts securing the servo to the mounting brackets and remove the servo from the airplane.

3-140. INSTALLATION OF PITCH SERVO. (PA-44-180) (Refer to Figure 3-28.)

- a. Install bridle cable pin in capstan with the longest portion of the bridle cable or the end with the red terminal down and tighten bridle cable pin lock screw.
- b. Wrap the end of the bridle cable with the red terminal one-half turn counterclockwise from the bridle cable pin on the upper capstan grooves and the other end of the bridle cable three-quarters of a turn clockwise from the bridle cable pin on the lower capstan grooves.
- c. Adjust the cable guards on the servo to provide a gap of .031 of an inch between the capstan and guard.
- d. Position the pitch servo on the mounting brackets located on the lower fuselage aft of the rear baggage area and secure with bolts, washers and nuts previously removed.
- e. REFER TO FIGURE 3-9 AND CHECK THAT THE CONTROL CABLE TENSION (Z) IS ADJUSTED TO 40 ± 5 POUNDS PRIOR TO ATTACHING THE BRIDAL CABLE CLAMPS. Ascertain area on cable where clamp attaches is clean, dry and free of all lubricants and anti-corrosive additives. Attach the bridle cable to the stabilator control cables. The bridle cable is drawn to the stabilator control cables and attached with clamps at the previously painted locations. The longest portion of the bridle cable or the end with the red ball attaches to the upper stabilator control cable. (Refer to Figure 3-28.) (Should the balance cable not be painted, position the control wheel full forward and with the servo disengaged, position the capstan pulley so that the bridle cable pin is aligned as shown in Figure 3-28.) Adjust the bridle cable clamps so that the bridle cable tension (Y) as shown in Figure 3-9 is $15 \pm 0 - 5$ pounds. Check the control cable tension forward of the bridle cable clamps and adjust, if necessary, to obtain 40 ± 5 pounds. If the control cables require adjustment, it will be necessary to readjust the bridle cable tension to $15 \pm 0 - 5$ pounds. Torque the bridle cable clamp bolts to 55 ± 5 inch-pounds.

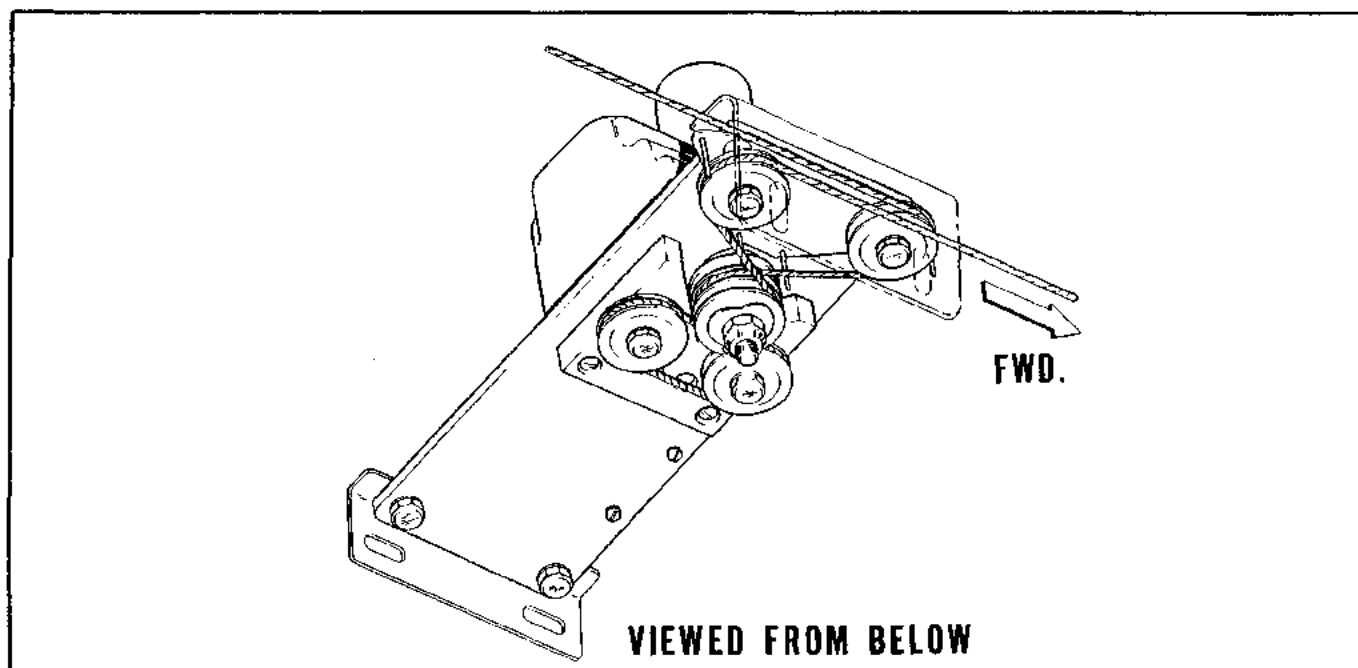

Figure 3-35. Pitch Trim Servo Installation, PA-44-180

- f. Connect the electrical connector to the servo.

CAUTION

Check security of bridle cable clamps and the bridle cable capstan pin. To do this, turn on the master switch and with the pitch command disc centered place the roll engage rocker switch and the pitch mode switch in the ON position. Move the control wheel manually to the extreme fore and aft positions to ascertain the clamps and pin do not change position. Next, operate the servo electrically by rotating the pitch command disc full up and full down. Examine the bridle cable to verify the clamps and pin do not change position. The clutch will slip during these operations.

- g. Install aft panel in rear baggage compartment and secure with appropriate screws.

3-141. REMOVAL OF PITCH TRIM SERVO. (PA-44-180)

The pitch trim servo is located directly aft of F.S. 156.00 on the lower fuselage.

- a. Access to the servo is through the rear baggage area.
- b. Remove the partition between the baggage compartment and aft section of the aircraft.

NOTE

To maintain cable routing of the trim cable during removal and installation of the trim servo, it is recommended that a service aid be fabricated from shop material such as two bridle cable clamps and a short length of cable or two blocks of wood pre-drilled with a bolt and nut inserted to maintain cable routing.

- c. Loosen trim cable turnbuckles to release cable tension.
- d. Disconnect the electrical connector from the trim servo.
- e. Remove the four bolts securing the trim servo to the mounting bracket.
- f. Unwrap the trim cable from the capstan and idler pulleys.
- g. Remove the trim servo from the airplane.

3-142. INSTALLATION OF PITCH TRIM SERVO. (PA-44-180) (Refer to Figure 3-35.)

- a. Position trim servo on mounting brackets and secure with mounting bolts.
- b. Route the trim cable from the forward part of the airplane around the aft inboard idler pulley, then around the bottom capstan groove and around the aft outboard idler pulley continuing around the forward outboard idler pulley and around the top capstan groove to the forward inboard idler pulley, to the aft section of the airplane.
 - c. Tighten the trim cable to obtain 10 ± 1 pounds cable tension.
 - d. Connect the electrical connection to the trim servo.
 - e. Check trim servo operation. (Refer to Section V.)
 - f. Replace and secure the partition between the baggage compartment and aft section of the aircraft.

➔ **3-143. REMOVAL OF CONSOLE. (PA-28RT-201 and PA-28RT-201T)**

The console is located in the lower left section of the instrument panel.

- a. Remove the roll command knob.
- b. Remove the four screws securing the face plate and remove face plate.
- c. Remove the console retaining screw. It is the screw located to the left of the trim meter on the console.
- d. Disconnect the electrical harness plugs CD-20 and CD-40 from the rear of the console.
- e. Remove the console from the airplane.

➔ **3-144. INSTALLATION OF CONSOLE. (PA-28RT-201 and PA-28RT-201T) (Refer to Figure 3-10.)**

- a. Place the console in the instrument panel cutout.
- b. Connect the electrical harness plugs, CD-20 and CD-40, to the rear of the console. (Make sure spring clip on CD-20 is secured.)
- c. Secure the console and install and secure the face plate.
- d. Install roll command knob and secure.
- e. Check console operation. (Refer to Section V.)

➔ **3-145. REMOVAL OF AUTOPILOT AMPLIFIER. (PA-28RT-201 and PA-28RT-201T)**

NOTE

The Electronic Trim Amplifier for the AltiMatic IIC is located on a mounting bracket which is secured to the top of the autopilot amplifier. Therefore, the Electronic Trim Amplifier and Autopilot Amplifier are removed from the airplane as one assembly.

The amplifier is located in the aft section of the fuselage, behind the battery, just forward of Sta. 191.0.

- a. Access to the amplifier may be gained by removing the aft baggage partition.
- b. Disconnect the electrical harness from the amplifier by removing the two knurled screws from the large amplifier connector and removing the connector from the amplifier.
- c. Disconnect the electrical connectors from the electronic trim amplifier.
- d. Unfasten the two fasteners that secure the amplifier to the mounting bracket.
- e. Remove the autopilot amplifier and electronic trim amplifier from the airplane as one unit.
- f. To remove the electronic trim amplifier and mounting bracket from the autopilot amplifier, simply remove screws and lockwashers securing the mounting bracket to the autopilot amplifier.

- ➔ 3-146. REMOVAL OF ELECTRONIC TRIM AMPLIFIER. (PA-28RT-201 and PA-28RT-201T)
 The electronic trim amplifier is located in the aft section of the fuselage, behind the battery, just forward of STA. 191.0.
- Access to the amplifier may be gained by removing the aft baggage partition.
 - Remove amplifier per instructions in previous paragraph.
 - Remove the four screws securing the electronic trim amplifier to the mounting bracket and remove amplifier from mounting bracket.
- ➔ 3-147. INSTALLATION OF ELECTRONIC TRIM AMPLIFIER. (PA-28RT-201 and PA-28RT-201T)
 (Refer to Figure 3-11.)
- Place the electronic trim amplifier on the mounting bracket and secure with attaching screws.
 - Place the mounting bracket with trim amplifier attached on the autopilot amplifier and secure with appropriate screws.
 - Install autopilot amplifier as per the instructions in the following paragraph.
- ➔ 3-148. INSTALLATION OF AUTOPILOT AMPLIFIER. (PA-28RT-201 and PA-28RT-201T) (Refer to Figure 3-11.)
- With the large thirty pin receptacle pointing outboard, place the amplifier on the mounting bracket located in the aft section of the fuselage behind the battery, just forward of STA. 191.0 and secure with fasteners.
 - Connect the harness to the autopilot amplifier by securing with the two screws previously removed from the receptacle.
 - Connect the electrical connectors to the electronic trim amplifier.
 - Check amplifier operation. (Refer to Section V.)
- ➔ 3-149. REMOVAL OF ATTITUDE GYRO. (PA-28RT-201 and PA-28RT-201T)
 The attitude gyro is located in the left instrument panel.
- Remove the face panel by removing the screws from around the perimeter of the panel.
 - Disconnect the electrical connector from the instrument.
 - Disconnect the vacuum line and the relief line from the instrument. Identify hoses to facilitate reinstallation. To prevent contamination, place protective covers over the ends of the hoses and the instrument ports.
- ➔ 3-150. INSTALLATION OF ATTITUDE GYRO. (PA-28RT-201 and PA-28RT-201T) (Refer to Figure 3-12.)
- Position the instrument in its proper panel cutout and secure with appropriate screws.
 - Remove any caps which were placed over the hoses and the instrument ports.
 - Connect hoses to proper ports of instrument.
 - Connect the electrical connector to the instrument.
 - Check operation of instrument. (Refer to Section V.)
 - Install face panel and secure with appropriate screws.
- ➔ 3-151. REMOVAL OF DIRECTIONAL GYRO AND/OR HORIZONTAL SITUATION INDICATOR. (PA-28RT-201 and PA-28RT-201T)
 The directional gyro is located in the left instrument panel.
- Remove the face panel by removing the screws from around the perimeter of the panel.
 - Disconnect the electrical connector from the instrument.
 - Disconnect the vacuum line and the relief line from the instrument. Identify hoses to facilitate reinstallation. To prevent contamination, place protective covers over the ends of the hoses and the instrument ports.
 - Remove the screws securing the instrument to the instrument panel and remove instrument.

➔ **3-152. INSTALLATION OF DIRECTIONAL GYRO AND/OR HORIZONTAL SITUATION INDICATOR. (PA-28RT-201 and PA-28RT-201T) (Refer to Figure 3-13.)**

- a. Position the instrument in its proper panel cut out and secure with appropriate screws.
- b. Remove any caps which were placed over the hoses and the instrument ports.
- c. Connect hoses to proper ports of instrument.
- d. Connect the electrical connector to the instrument.
- e. Check operation of instrument. (Refer to Section V.)
- f. Install face panel and secure with appropriate screws.

➔ **3-153. REMOVAL OF ALTITUDE HOLD UNIT (PA-28RT-201 and PA-28RT-201T)**

The altitude hold unit is located in the aft section of the fuselage, behind the battery, just forward of STA. 191.0. The unit is complete with its own mounting bracket and shock mounts which in turn are secured to a frame mounted bracket.

- a. Access may be gained to the unit by removing the aft baggage partition.
- b. Disconnect the electrical connector from the altitude hold unit.
- c. Disconnect the static hose by releasing the clamp and sliding the hose off the port. To prevent contamination, place protective covers over the end of the hose and the instrument port.
- d. Loosen the clamp screws securing the unit to the mounting bracket.
- e. Remove the altitude hold unit from the airplane.

➔ **3-154. INSTALLATION OF ALTITUDE HOLD UNIT. (PA-28RT-201 and PA-28RT-201T) (Refer to Figure 3-33.)**

- a. Position the altitude hold unit on the mounting bracket located in the aft section of the fuselage just forward of STA. 191.0. Position unit so static port is pointing aft and secure by tightening clamp screws to 5 ± 1 inch pounds.
- b. Remove any caps which were placed over the ends of the hose and the instrument port.
- c. Connect the hose from the rate of climb indicator to the port marked static on the unit and secure with clamp.
- d. Connect the electrical connector to the unit.
- e. Check operation of altitude hold unit. (Refer to Section V.)

➔ **3-155. REMOVAL OF RELAY BOX. (PA-28RT-201 and PA-28RT-201T)**

The relay box is attached to a mounting bracket located behind the right instrument panel along the right side of the fuselage.

- a. Access to the relay box is from beneath the right instrument panel.
- b. Disconnect the electrical connector from the relay box.
- c. Remove the screws securing the relay box to the mounting bracket.
- d. Remove the relay box from the airplane.

➔ **3-156. INSTALLATION OF RELAY BOX. (PA-28RT-201 and PA-28RT-201T) (Refer to Figure 3-34.)**

- a. Position the relay box on the bracket located behind the right instrument panel along the right side of the fuselage and secure with appropriate screws.
- b. Connect the electrical connector to the relay box.
- c. Check operation of relay box. (Refer to Section V.)

➔ **3-157. REMOVAL OF ROLL SERVO. (PA-28RT-201 and PA-28RT-201T)**

The roll servo is located beneath the back seat on the pilot's side of the aircraft.

- a. Remove the third and fourth seats and center floor panel to gain access to this area.
- b. Disconnect the electrical connector from the servo.
- c. Paint the aileron balance cable where the bridle cable clamps are located and then remove the two bridle cable clamps. (DO NOT paint the bridle cable end terminals as one terminal is painted red to facilitate reinstallation.)
- d. Remove the bolts, washers and nuts that secure the roll servo to the mounting bracket.
- e. Remove the roll servo from the airplane.

31-158. INSTALLATION OF ROLL SERVO. (PA-28RT-201 and PA-28RT-201T) (Refer to Figure 3-27.)

- a. Insert bridle cable pin in capstan and tighten bridle cable pin lock screw.
- b. Wrap the bridle cable one full turn each direction around the capstan from the bridle cable pin.
- c. Adjust the cable guards on the servo to provide a gap of .031 of an inch between the cable and guard.
- d. Position the servo on the mounting bracket located in the area beneath the floor aft of the main spar.

Secure the servo with the bolts, washers and nuts previously removed.

e. **REFER TO FIGURE 3-8 AND CHECK THAT THE CONTROL CABLE TENSION (Z) IS ADJUSTED TO 40 ± 5 POUNDS, PRIOR TO ATTACHING THE BRIDLE CABLE CLAMPS.** Ascertain area on cable where clamp attaches is clean, dry and free of all lubricants and anti-corrosive additives. Attach the bridle cable to the aileron balance cable. The bridle cable is drawn to the balance cable and attached with clamps at the previously painted locations on the balance cable. The longest portion of the bridle cable, or the end with the red ball, extends outboard toward the left side of the airplane. (Refer to Figure 3-27.) (Should the balance cable not be painted, position the control wheel in neutral and align the bridle cable pin, installed in the capstan, as shown in Figure 3-27.) Adjust the bridle cable clamps so the bridle cable tension (Y) is equal to $25 + 0 - 5$ pounds. Recheck the control cable tension from the bridle cable clamps outward and adjust, if necessary. If aileron cables require adjustment, it may be necessary to readjust the bridle cable tension. Torque the bridle cable clamp bolts to 55 ± 5 inch pounds.

- f. Connect the electrical connector to the servo.

CAUTION

Check security of bridle cable clamps and the bridle cable capstan pin. To do this, turn on the master switch and with the roll command knob centered place the roll engage rocker switch in the ON position to engage the roll servo. Turn the control wheel manually to the extreme left and right positions to ascertain the clamps and pin do not change position. Next operate the servo electrically by rotating the roll command knob to its extreme left and right position. Examine the bridle cable to verify the clamps and pin do not change position. The clutch will slip during these operations.

- g. Install the floor panel, seat belts and seats.

3-159. REMOVAL OF PITCH SERVO. (PA-28RT-201 and PA-28RT-201T)

The pitch servo is located in the aft section of the fuselage behind STA. 247.125 in the approximate center of the aircraft.

- a. To gain access to this area remove the aft baggage partition and the round inspection plates on both sides of the fuselage at STA 259.7.
- b. Disconnect the electrical connection from the servo.
- c. Paint the stabilator control cables where the bridle cable clamps are located and then remove the two bridle cable clamps. (DO NOT paint the bridle cable end terminals as one terminal is painted red to facilitate reinstallation.)
- d. Remove the bolts, washers and nuts securing the servo to the mounting brackets and remove the servo from the airplane.

3-160. INSTALLATION OF PITCH SERVO. (PA-28RT-201 and PA-28RT-201T) (Refer to Figure 3-28.)

- a. Install bridle cable pin in capstan with the longest portion of the bridle cable down and tighten bridle cable pin lock screw.
- b. Wrap the long end of the bridle cable one-half turn counterclockwise from the bridle cable pin on the upper capstan grooves and the other end of the bridle cable three-quarters of a turn clockwise from the bridle cable pin on the lower capstan grooves.
- c. Adjust the cable guards on the servo to provide a gap of .031 of an inch between the capstan and guard.

d. Position the pitch servo on the mounting brackets located on the lower fuselage aft of the rear baggage area and secure with bolts, washers and nuts previously removed.

e. **REFER TO FIGURE 3-9 AND CHECK THAT THE CONTROL CABLE TENSION (Z) IS ADJUSTED TO 40 ± 5 POUNDS PRIOR TO ATTACHING THE BRIDLE CABLE CLAMPS.** Ascertain area on cable where clamp attaches is clean, dry and free of all lubricants and anti-corrosive additives. Attach the bridle cable to the stabilator control cables. The bridle cable is drawn to the stabilator control cables and attached with clamps at the previously painted locations. The longest portion of the bridle cable or the end with the red ball attaches to the upper stabilator. (Refer to Figure 3-28.) (Should the balance cable not be painted, position the control wheel full forward and with the servo disengaged, position the capstan pulley so that the bridle cable pin is aligned as shown in Figure 3-28.) Adjust the bridle cable clamps so that the bridle cable tension (Y) as shown in Figure 3-9 is $15 + 0 - 5$ pounds. Check the control cable tension forward of the bridle cable clamps and adjust if necessary to obtain 40 ± 5 pounds. If the control cables require adjustment, it will be necessary to readjust the bridle cable tension to $15 + 0 - 5$ pounds. Torque the bridle cable clamps bolts to 55 ± 5 inch-pounds.

f. Connect the electrical connector to the servo.

CAUTION

Check security of bridle cable clamps and the bridle cable capstan pin. To do this, turn on the master switch and with the pitch command disc centered place the roll engage rocker switch and the pitch mode switch in the ON position. Move the control wheel manually to the extreme fore and aft positions to ascertain the clamps and pin do not change position. Next, operate the servo electrically by rotating the pitch command disc full up and full down. Examine the bridle cable to verify the clamps and pin do not change position. The clutch will slip during these operations.

g. Install the aft panel in rear baggage compartment and the round inspection plates and secure with appropriate screws.

3-161. REMOVAL OF PITCH TRIM SERVO. (PA-28RT-201 and PA-28RT-201T)

The pitch trim servo is located directly aft of STA. 156.00 on the lower fuselage.

- a. Access to the servo is through the rear baggage area.
- b. Remove the partition between the baggage compartment and aft section of the aircraft.

NOTE

To maintain cable routing of the trim cable during removal and installation of the trim servo, it is recommended that a service aid be fabricated from shop material such as two bridle cable clamps and a short length of cable or two blocks of wood pre-drilled with a bolt and nut inserted to maintain cable routing.

- c. Loosen trim cable turnbuckles to release cable tension.
- d. Disconnect the electrical connector from the servo.
- e. Remove the four mounting bolts securing the trim servo to the mounting bracket.
- f. Unwrap the trim cable from the capstan and idler pulleys.
- g. Remove the trim servo from the airplane.

3-162. INSTALLATION OF PITCH TRIM SERVO. (PA-28RT-201 and PA-28RT-201T) (Refer to Figure 3-29.)

- a. Position trim servo on mounting brackets and secure with mounting bolts.
- b. Route the trim cable from the forward part of the airplane around the bottom capstan groove to the forward idler pulley and around it, continue around the aft idler pulley and then around the top capstan groove to the aft section of the airplane.
- c. Tighten the trim cable to obtain 10 ± 1 pounds cable tension.
- d. Connect the electrical connector to the trim servo.
- e. Check trim servo operation. (Refer to Section V.)
- f. Install aft panel in rear baggage compartment and secure with appropriate screws.

3-163. REMOVAL OF NAV FLAG ADAPTER. (PA-23-250 Six Place, S/N 27-7554001, 7554074 to 7754127; PA-31, S/N 31-7512023 to 7712064; PA-31-350, S/N 31-7552054 to 7752100, 31-7752102 to 7752113 and PA-31P, S/N 31P-7630014 to 7730012)

The NAV Flag Adapter is located behind the left instrument panel, mounted on the left outboard fuselage nose channel for the PA-23-250 (six place) and on the radio support bracket for the PA-31-310; -325; -350 and PA-31P.

NOTE

The NAV Flag Adapter is used only in certain NSD-360 Compass systems that do not use the Edo-Aire Mitchell AK-423, 1C707 or 1C707-1 VOR/Localizer converters. Compass systems using the above converters do not require the NAV Flag Adapter.

- a. Access to the NAV Flag Adapter is from beneath the instrument panel.
- b. Disconnect the electrical connector from the NAV Flag Adapter.
- c. Remove the screws securing the NAV Flag Adapter to its mounting location.
- d. Remove the NAV Flag Adapter from the airplane.

3-164. INSTALLATION OF NAV FLAG ADAPTER. (PA-23-250 Six Place, S/N 27-7554001, 7554074 to 7754127; PA-31, S/N 31-7512023 to 7712064; PA-31-350, S/N 31-7552054 to 7752100, 31-7752102 to 7752113 and PA-31P, S/N 31P-7630014 to 7730012) (Refer to Figure 3-36.)

- a. Position the NAV Flag Adapter at its mounting location behind the instrument panel and secure with appropriate screws.
- b. Connect the electrical connector to the NAV Flag Adapter.
- c. Remove the screws securing the NAV Flag Adapter to the nose channel and/or support bracket.

3-165. REMOVAL OF NAV FLAG ADAPTER. (PA-32-260, S/N 32-7600001 to 7700017; PA-32-300, S/N 32-7640001 to 7740075; PA-32R-300, S/N 32R-7680001 to 7780350 and PA-34-200T, S/N 34-7670001 to 7770261)

The NAV Flag Adapter is located behind the right instrument panel on the firewall mounted on the existing hat.

NOTE

The NAV Flag Adapter is used only in certain NSD-360 Compass systems that do not use the Edo-Aire Mitchell AK-423, 1C707 or 1C707-1 VOR/Localizer converters. Compass systems using the above converters do not require NAV Flag Adapter.

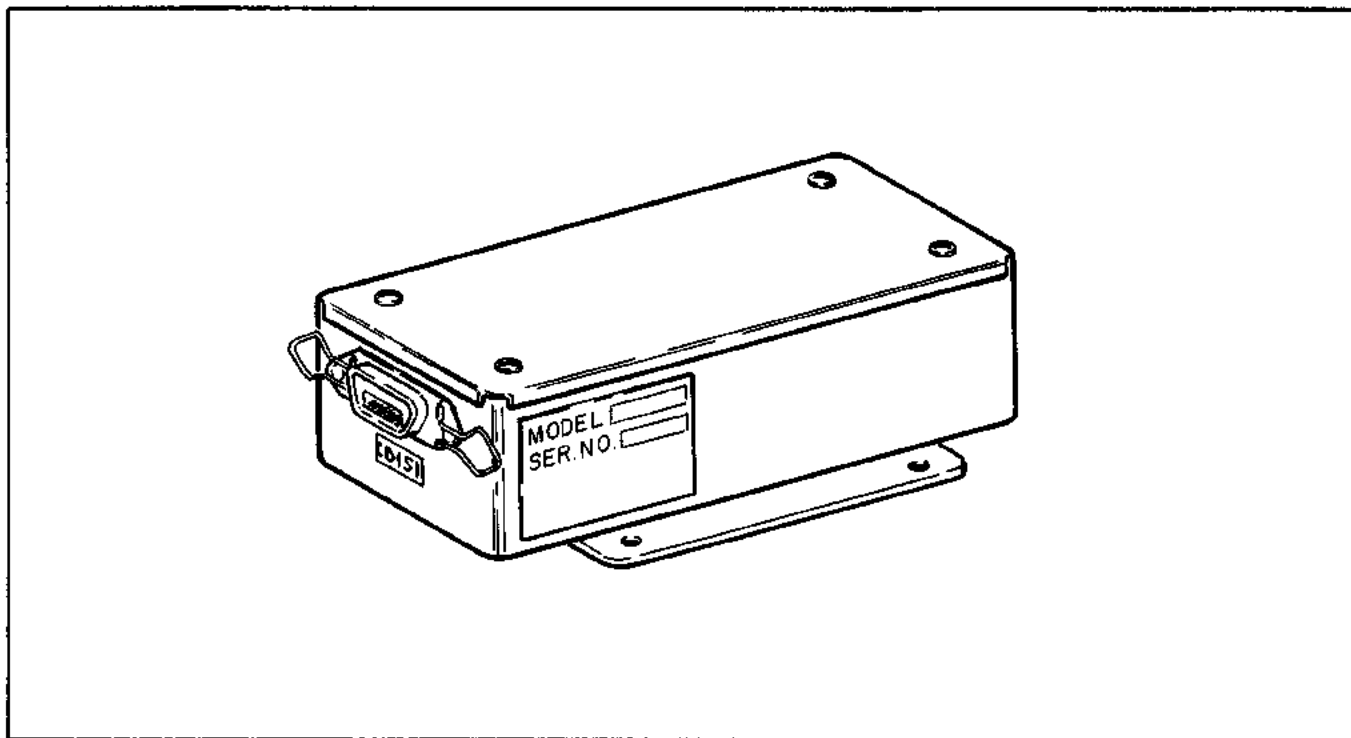

Figure 3-36. NAV Flag Adapter Installation

- a. Access to the NAV Flag Adapter is from beneath the instrument panel.
- b. Disconnect the electrical connector from the NAV Flag Adapter.
- c. Remove the screws securing the NAV Flag Adapter to its mounting location.
- d. Remove the NAV Flag Adapter from the airplane.

3-166. INSTALLATION OF NAV FLAG ADAPTER. (PA-32-260, S/N 32-7600001 to 7700017; PA-32-300, S/N 32-7640001 to 7740075; PA-32R-300, S/N 32R-7680001 to 7780350 and PA-34-200T, S/N 34-7670001 to 7770261) (Refer to Figure 3-36.)

- a. Position the NAV Flag Adapter at its mounting location on the firewall and secure with appropriate screws.
- b. Connect the electrical connector to the NAV Flag Adapter.
- c. Check operation of the NAV Flag Adapter (Refer to Section V.)

3-167. REMOVAL OF KA-52 AUTOPILOT ADAPTER.

The KA-52 autopilot adapter is located on a mounting bracket behind the left instrument panel.

NOTE

The only installation incorporating the KA-52 autopilot adapter is the King KC5-55 Compass System. The EDO-AIRE Mitchell Compass System does not require the KA-52 autopilot adapter.

- a. Access to the KA-52 autopilot adapter is from beneath the instrument panel.
- b. Disconnect the electrical connector from the KA-52 adapter.
- c. Remove the screws securing the KA-52 adapter to the mounting bracket.
- d. Remove the KA-52 adapter from the airplane.

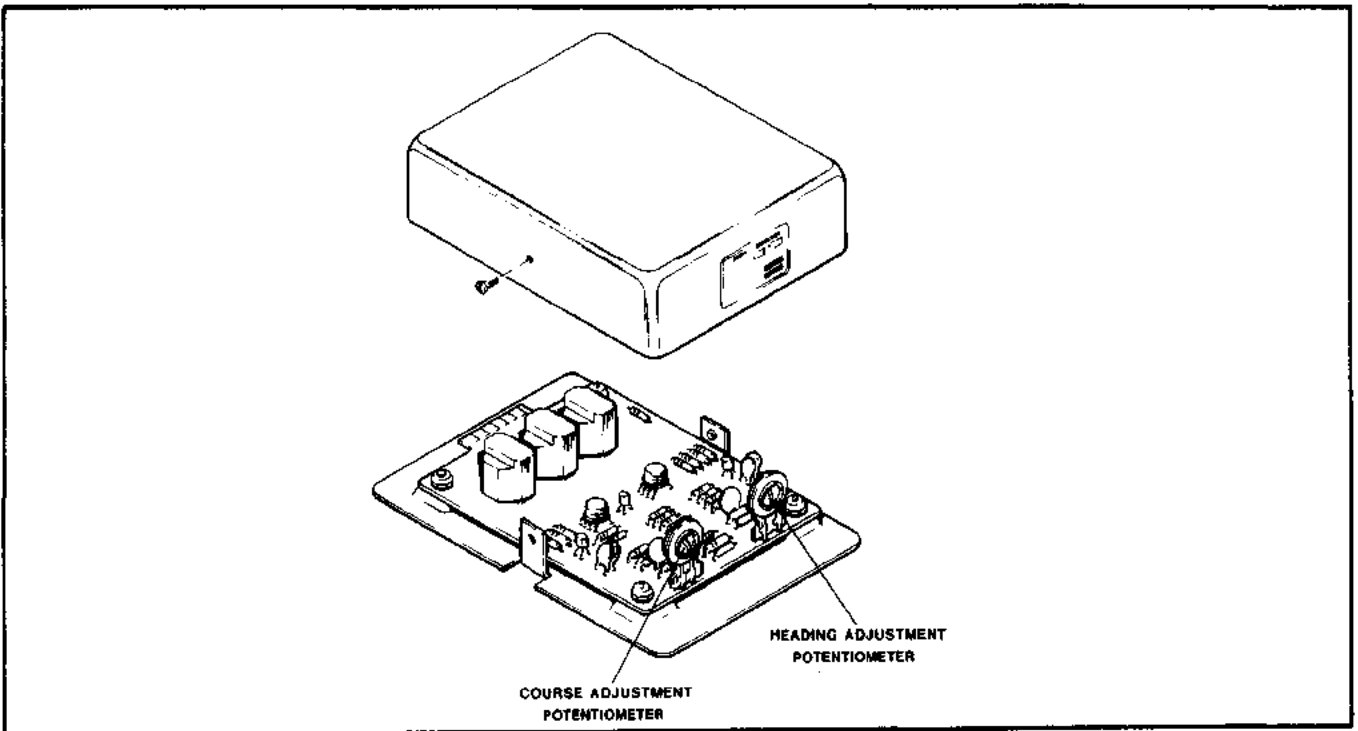

Figure 3-37. KA-52 Autopilot Adapter Installation

3-168. INSTALLATION OF KA-52 AUTOPILOT ADAPTER. (Refer to Figure 3-37.)

- a. Position the KA-52 adapter on the mounting bracket located behind the instrument panel and secure with appropriate screws.
- b. Connect the electrical connector to the KA-52 adapter.
- c. Check operation of KA-52 adapter. (Refer to Section V.)

SECTION IV

TEST EQUIPMENT

Paragraph	Page
4-1. Introduction - Test Equipment Requirements. AutoPilot Test Kit, Piper P/N 753 439 (66D141)	4-1
4-2. 66D141-1 Gyro Substitute	4-1
4-3. 66D141-2 Power Section	4-1
4-4. 66D141-3 Console Substitute	4-2
4-5. 66D141-4 Radio Coupler Tester	4-4
4-6. 66D141 Test Kit and Cables	4-4
4-7. Troubleshooting	4-4
4-8. Checking Servo Motor Current Drain (No Load)	4-7

SECTION IV

TEST EQUIPMENT

4-1. INTRODUCTION - TEST EQUIPMENT REQUIREMENTS. AUTOPILOT TEST KIT, PIPER P/N 753 439 (66D141).

a. The 66D141 Test Kit is designed to facilitate testing the AltiMatic IIC Autopilot System on a substitution basis. Provisions are made to substitute into an operating system any major component except the amplifier. Each piece of test equipment can be used for various tests, not limited to what is given in this description.

b. The Test Kit consists of four major sections plus necessary connecting cables. These sections are listed as follows:

1. 66D141-1 Directional and Attitude Gyro Substitute.
2. 66D141-2 Power Section.
3. 66D141-3 Console Substitute.
4. 66D141-4 Radio Coupler Tester.

4-2. 66D141-1 GYRO SUBSTITUTE. (Refer to Figure 4-1.)

a. With this section, both the directional gyro and the artificial horizon can be replaced (simultaneously) with substitute signal sources. The directional gyro signal is variable in steps to provide outputs corresponding to 0, 10 and 45 degrees left and right. The zero position is used to provide an accurate zero signal so that the roll centering adjustment can be accurately set or checked for range of control. The 10° outputs are used to check the heading sensitivity of the amplifier command channel and, by means of comparison, to determine whether or not the directional gyro in question provides a signal usable for operation with the system. The 45° outputs are provided for the purpose of checking radio coupler intercept angles and can be used to simulate the course selector of the directional gyro being moved to a new heading.

A large vernier knob, marked attitude gyro with a dual scale marked roll degrees and pitch degrees, is provided to give a measurement in degrees of deviation from straight and level flight in the roll or pitch mode of operation.

4-3. 66D141-2 POWER SECTION. (Refer to Figure 4-2.)

a. With this equipment, amplifier output and servo performance can be observed. Two connectors are provided so the cable to either servo can be intercepted. A pilot light is provided to indicate the presence of solenoid voltage. A voltmeter is provided to monitor the signal actually being applied to the servo motor. A five position selector switch is provided to select various modes of servo operation. These are: Two positions on the left side marked "BAT," which will allow the operator to apply a full signal directly to the servo motor to check operation in either direction. Two positions on the right side marked "AMPL." One is marked "RES." and serves to apply a resistive load to the amplifier in the event the servo motor is not available to the technician. The other position in this mode is marked "MTR.," and measures the signal being applied to the servo motor.

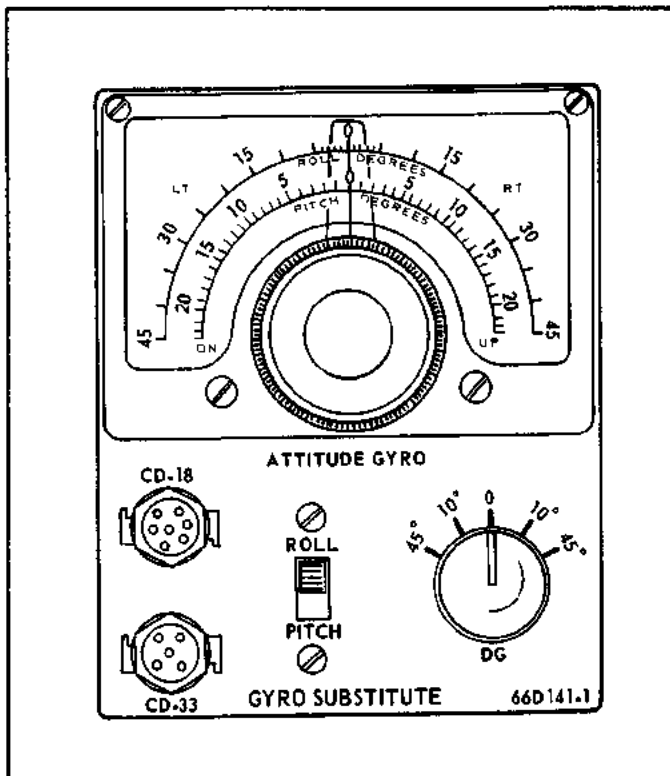

Figure 4-1. Gyro Substitute

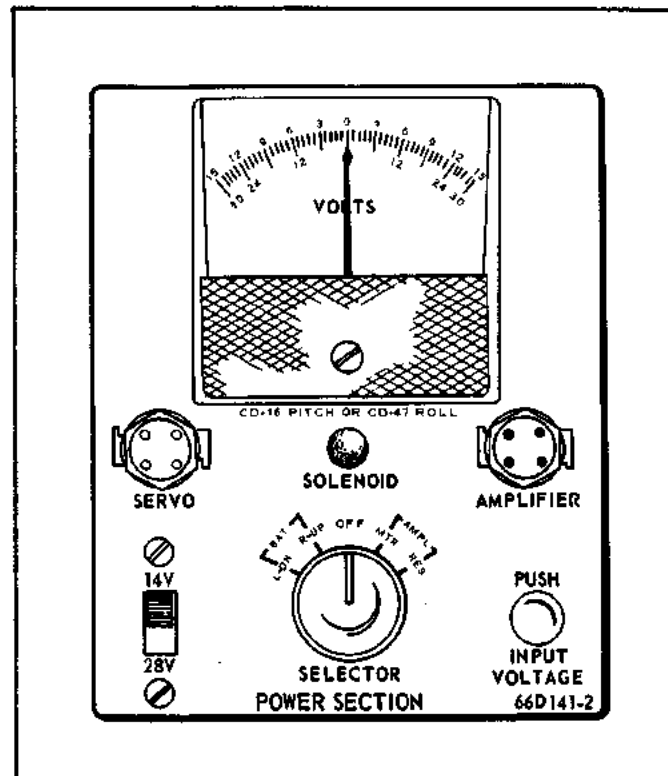

Figure 4-2. Power Section

4-4. 66D141-3 CONSOLE SUBSTITUTE. (Refer to Figure 4-3.)

a. Electrically, this console is interchangeable with the standard autopilot console for test purposes. Using the substitute console, it is possible to determine rapidly if the combination of signal sources and amplifier can be brought within usable limits by means of the adjustments provided on the standard console. Also, it serves as a substitute to aid in determining whether or not the installed console or altitude selector is defective.

b. An OFF-ON power switch and 4 two-position slide switches are provided. These are:

1. Selector switch for autopilot operating voltage.
2. Directional gyro or manual selector switch corresponding to the roll and HDG push button switches on the console.
3. Altitude control or manual selector switch corresponding to the pitch and altitude push button switches on the console.
4. Minimum and maximum limit selector switch, equivalent to Min. (Full CCW) and Max. (Full CW) positions of limit potentiometers on the console.

c. There are five adjustments provided. These are:

1. Roll manual knob corresponding to the roll manual control on the console.
2. Pitch manual knob corresponding to the pitch manual control on the console.
3. Roll trim knob corresponding to the roll centering adjustment potentiometer on the console.
4. Pitch trim knob corresponding to the pitch centering adjustment potentiometer on the console.
5. Altitude control knob simulating the altitude hold on the console.

d. The connector from the console is plugged into the CD-20 receptacle. The CD-10 receptacle replaces the altitude hold for bench or in-airplane tests.

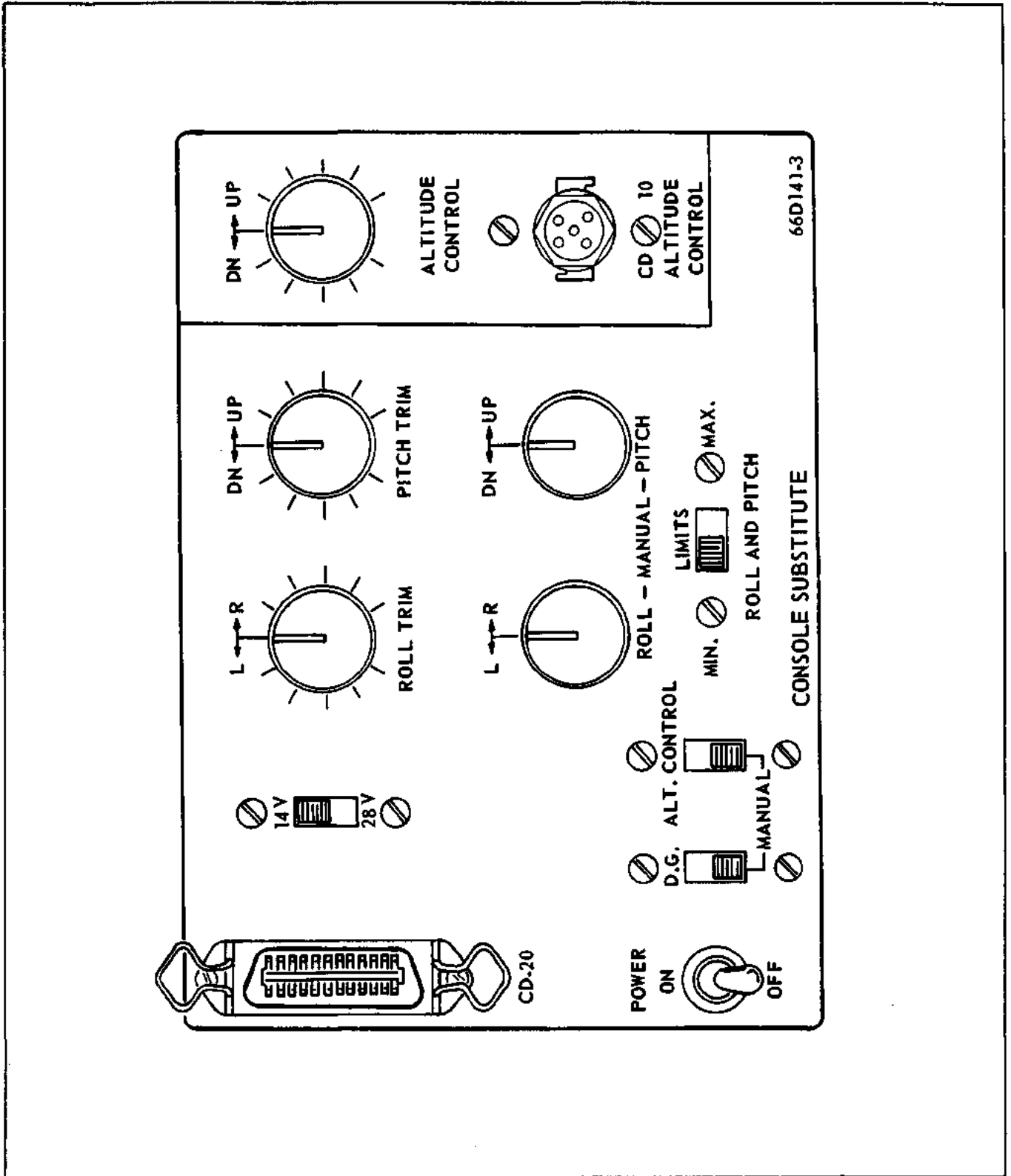

Figure 4-3. Console Substitute

4-5. 66D141-4 RADIO COUPLER TESTER. (Refer to Figure 4-4.)

a. The coupler tester contains a simulated radio signal source and intercepts the coupler output to provide direct monitoring of coupler performance. When used with the directional gyro signal source described in paragraph 4-2, and with an autopilot amplifier as a source of power, a complete static testing of coupler performance is possible. The radio coupler tester consists of the following functions:

1. Output meter to measure the output of the radio coupler.
2. Simulated OMNI meter to simulate an OMNI signal applied to the system or to measure the actual OMNI output signal from the airplane radio.
3. Three connectors, two of which are to intercept the lead from the amplifier to the Radio Coupler (CD-33) and the third (CD-34) to either apply a simulated radio signal or check the actual signal from the OBI to the Radio Coupler.
4. Radio signal substitute knob which corresponds to the OBS on the OBI.
5. A two position slide switch to select a corresponding autopilot operating voltage.
6. A MIC key push button corresponding to the MIC key in the airplane.
7. A push to null button is not used with the III Series Autopilots.
8. Two DC input connectors for power to operate the MIC key portion of the tester and to supply power for the face plate lights of the coupler.

NOTE

The radio signal substitute portion of the tester has an internal power supply consisting of one 9V battery. When full deflection of the simulated OMNI signal can not be obtained under load, replace battery.

CAUTION

Do not attempt to troubleshoot a 1C-388-2 radio coupler thru by-passing it. By connecting the A/P harness connector directly into the NSD-360/360A CD-33 plug, the computer/amplifier oscillator will probably burn out. (A 1C-388 coupler may be by-passed directly to a 52D54 D.G. with "bug," but the same procedure will not work with an NSD.)

4-6. 66D141 TEST KIT AND CABLES.

a. Shown in Figure 4-5 is a block diagram of the complete test kit instruments and cable storage area. Each test kit has a serial number. Make sure the equipment in the kit has the correct serial number. When referring to the factory for service or calibration of any instrument, give serial number of the equipment.

b. The 66D141 Test Kit contains a set of test cables. They are marked with the number which corresponds with either the test equipment or the piece being tested. Refer to Section VI for Wiring Diagrams of the AltiMatic IIIC Autopilot System.

4-7. TROUBLESHOOTING.

a. By determining in advance from symptoms described by the pilot, the serviceman may decide which section of the autopilot may be causing the trouble and isolate the defective unit rapidly by a logical substitution method. Refer to Table IV-I before attempting to troubleshoot the Autopilot System. Isolate the trouble into one of three groups. The first group corresponds to the inputs of the autopilot listed under the term input in the trouble isolation diagram. It is recommended that the technician, by use of the appropriate test equipment, reproduce the input signals of the forward group and observe the autopilot responds either correctly or incorrectly. The reason for this is that this group is the easiest group to work

on. If, with the correct inputs, the autopilot still does not respond correctly (by noting the servo motor rotation of the airplane control system) the component called out in the middle group should be removed, set up and monitored on the bench as outlined in Section V. If all inputs are correct and the components of the middle group are functioning properly, only then should the airplane control system, as given in the output group, be referred to for troubleshooting. Refer to Section III for proper cable tension and bridle cable installation.

b. For proper cable tensions and correct bridle cable positioning, refer to the appropriate paragraph in Section III for the unit and airplane being serviced.

c. The Clutch Adjustment Procedure is not authorized in the field at this time on copper/carbon

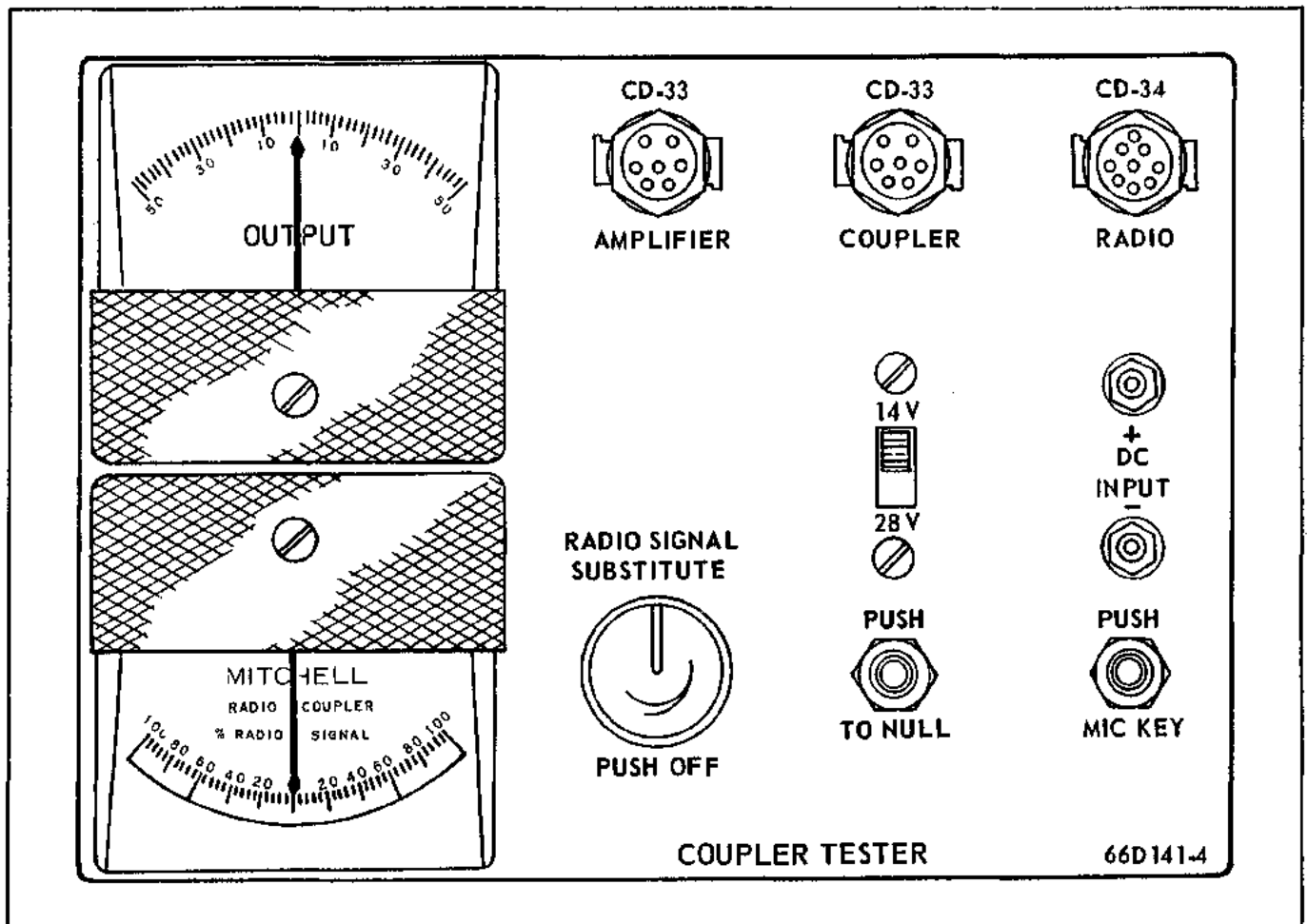

Figure 4-4. Radio Coupler Tester

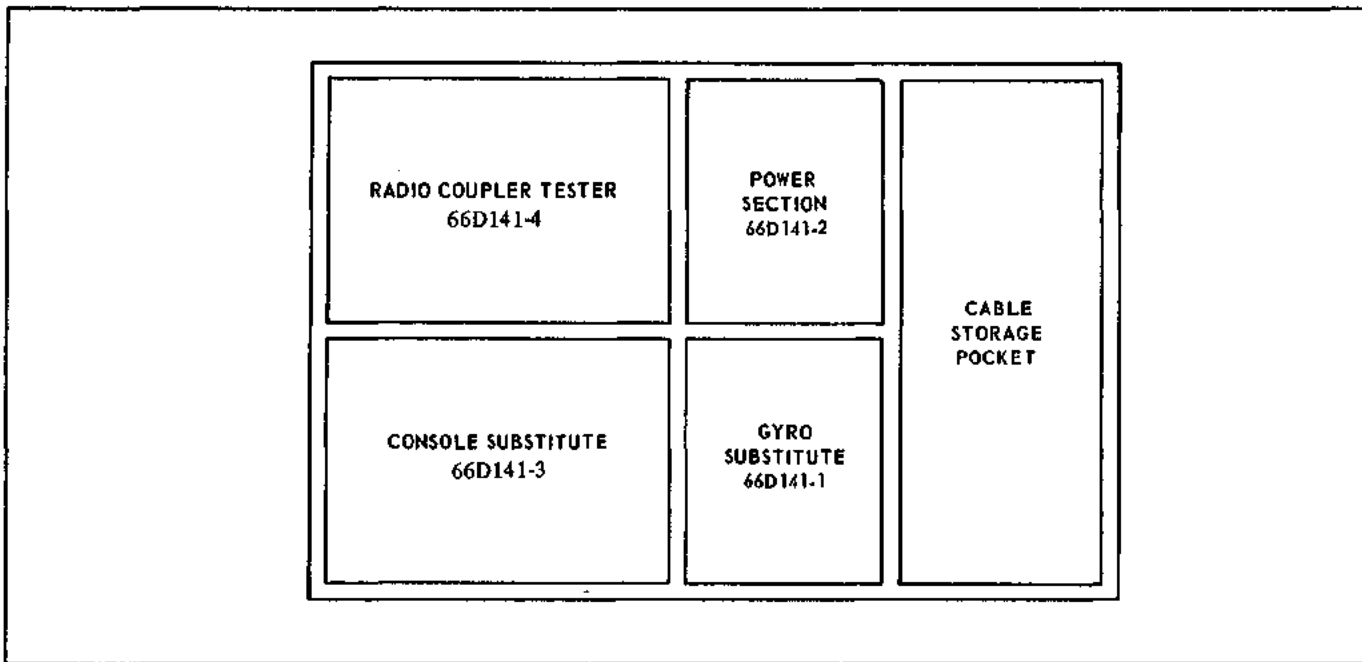

Figure 4-5. Block Diagram of 66D141 Test Kit

type clutches as per manufacturer, EDO-AIRE MITCHELL.

d. The servo motor current drain test is outlined in the following paragraph.

e. For electronic troubleshooting of the Altimatec IIC, refer to the appropriate Bench Set-up Procedure in Section V.

4-8. CHECKING SERVO MOTOR CURRENT DRAIN (NO LOAD).

The servo motor may be checked in the airplane for current drain using a standard ammeter (or equivalent) in series with the motor. The following procedure will facilitate this check.

NOTE

If the servo motor current drain is over one-half amp, it must be replaced.

- a. It shall be necessary to improvise an adapter for the CD-16 or CD-47 plug.
- b. Connect the negative side of a 12-volt source to pin "C" on servo motor plug.
- c. Connect pin "D" to one lead of the ammeter.
- d. Connect the remaining ammeter lead to the positive side of the 12-volt source.

CAUTION

Before applying voltage as described in the following steps, note the initial application of voltage should only be for ONE SECOND to ascertain there are no shorts which will cause damage to the meter.

- e. Apply voltage from the 12-volt source for ONE SECOND to ascertain no shorts exist.
- f. Apply voltage from the 12-volt source and take current reading. Turn off voltage after reading has been obtained.
- g. To check the motor operation in the opposite direction, reverse connections "C" and "D" on the servo motor plug and apply voltage and check current reading. If the reading is more than one-half amp, the servo motor must be replaced.

NOTE

Motor must be tested in both directions.

TABLE IV-I. TROUBLE ISOLATION BLOCK DIAGRAM

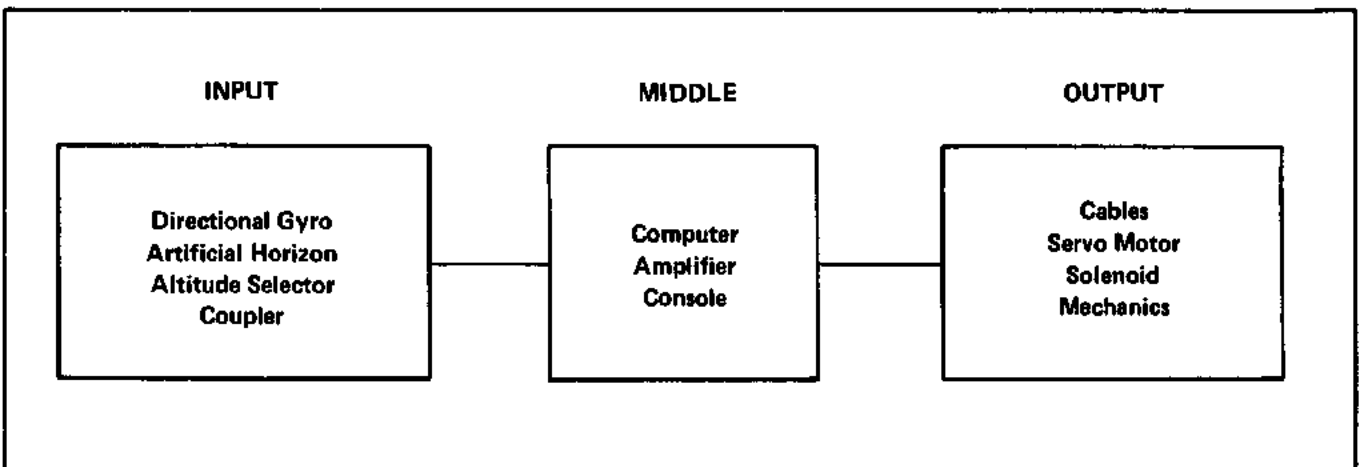

SECTION V

SET-UP PROCEDURES

Paragraph	Page
5-1. Introduction	5-1
5-2. Bench Set-Up and Adjustment of AltiMatic IIC Console and 1C515-1/1C515-3 Amplifier Without Radio Coupler	5-1
5-3. Roll Threshold Adjustment for AltiMatic IIC	5-6
5-4. Pitch Bench Set-Up for AltiMatic IIC	5-8
5-5. Pitch Threshold Adjustment for AltiMatic IIC	5-10
5-6. AltiMatic IIC Ground Check Without Radio Coupler (Roll)	5-12
5-7. AltiMatic IIC Flight Adjustments Without Radio Coupler (Roll)	5-12
5-8. Bench Set-Up and Adjustments for AltiMatic IIC Console and 1C515-1/1C515-3 Amplifier With Radio Coupler	5-14
5-9. Roll Threshold Adjustment for AltiMatic IIC	5-21
5-10. Pitch Bench Set-Up for AltiMatic IIC	5-23
5-11. Pitch Threshold Adjustment for AltiMatic IIC	5-24
5-12. AltiMatic IIC Ground Checks With Radio Coupler (Roll)	5-25
5-13. Ground Check - Pitch	5-26
5-14. AltiMatic IIC Flight Adjustments With Radio Coupler (Roll)	5-27
5-15. AltiMatic IIC Flight Adjustment - Pitch	5-29
5-16. AltiMatic IIC Ground Check (Optional Yaw Damper)	5-30
5-17. Check and Adjusting Radio Gain	5-30
5-18. Piper Omni/Localizer Coupler Modification (1C388 Series)	5-32
5-19. NAV Converter (1C707) Alignment Procedure	5-33
5-20. Adjustments of Slaving Sub-System	5-37
5-21. AltiMatic IIC With Optional King KCS-55 Compass System Alignment Procedure	5-39
→ 5-22. Yaw Damper Ground Check	5-42

SECTION V
SET-UP PROCEDURES

5-1. INTRODUCTION. This section contains information on how to set up the AltiMatic IIC on the bench. There is also information on checking the autopilot on the ground. Flight adjustments, which are the final adjustments, are given in this section also. For the removal and installation of the AltiMatic IIC components, refer to Section III, Removal and Installation.

NOTE

It is MANDATORY that the AltiMatic IIC be set up according to bench set-up procedures in this section prior to installation in the airplane.

CAUTION

When the AltiMatic IIC is being adjusted, excessive turning of the adjustment potentiometers should be avoided as this may cause premature failure of the potentiometer.

5-2. BENCH SET-UP AND ADJUSTMENT OF ALTIMATIC IIC CONSOLE AND 1C515-1/1C515-3 AMPLIFIER WITHOUT RADIO COUPLER.

NOTE

If either the console or the amplifier is replaced, the console must be set up through its complete adjustment procedure.

a. The following equipment will be required from the Autopilot Test Kit, Piper P/N 753 439 (66D141).

1. Gyro Substitute Test Box 66D141-1.
2. Power Section Test Box 66D141-2.
3. Console Substitute Box 66D141-3.
4. AltiMatic III test harness, identified by a large 30-pin AMP connector feeding through five connecting cables labeled CD-16, CD-18, CD-20, CD-33 and CD-47. This cable also contains two white wires, one wire terminating at a Delco fitting labeled CD-27 and the other terminating at a knife connector labeled CD-26.

5. Servo Extension Cable CD-47/CD-16 with a male CD-47 connector on one end and a female CD-47 connector on the other end.

b. BENCH SET-UP AND ADJUSTMENT PROCEDURES ARE AS FOLLOWS:

1. Remove the console face plate by removing the roll command knob and four face plate mounting screws. After removing the face plate, reinstall the roll command knob to facilitate accomplishing bench set-up adjustments.

2. Determine that the **VOLTAGE SELECTOR SWITCHES**, located on top plate of amplifier and the right side of the console are in the same position (14 or 28-volts DC) as the bench power supply. This will insure proper autopilot operation and prevent damage to the components.
3. Hold the **AMPLIFIER** with 30-pin amplifier board facing you. Plug large 30-pin AMP connector of the test harness onto the amplifier board with the cable fanning out to your right. Identification placard on the amplifier should be visible.
4. Plug AMP connector CD-20 into the CD-20 receptacle located on the rear of the console.
5. Check that all **WHITE ENGAGE SWITCHES** are pushed to their "OFF" positions on the autopilot console.
6. Plug the 4-pin male CD-47 connector into the female 4-pin receptacle, located on the right hand side of the Power Section Test Box. This receptacle is labeled **AMPLIFIER**. On the Power Section Test Box, find the **VOLTAGE SELECTOR SWITCH** on the lower left hand corner and insure that this switch is positioned to match the bench power supply and the amplifier voltage selector switch as in Step 2 (14 or 28-volts DC).
7. Rotate **SELECTOR KNOB** on Power Section Test Box to the **CENTER** or "OFF" position.
8. Plug the female 7-pin CD-33 connector into the male 5-pin CD-33 connector located on the bottom left hand corner of the Gyro Substitute Test Box.
9. Plug the 7-pin female CD-18 connector into the 7-pin male CD-18 connector on the left hand side of the Gyro Substitute Test Box.
10. Rotate the **LARGE VERNIER CONTROL KNOB** on the Gyro Substitute Test Box to the centered **ZERO** position reading the **TOP SCALE** labeled **ROLL DEGREES**.
11. Immediately below the large vernier knob, find a **ROLL** or **PITCH SELECTOR SLIDE SWITCH**. Move this switch to the "ROLL" position.
12. Immediately to the right of the slide switch, find a **DIRECTIONAL GYRO SELECTOR KNOB**. Rotate this knob to **ZERO** or straight "UP" position.
13. Set aside the remaining cables labeled CD-16 and CD-10. Connect a ground lead to the bottom mounting flange of the AltiMatic IIC amplifier.

CAUTION

DO NOT place the ground lead near the output transistors located between the cooling fins along the side of the amplifier.

14. Connect the face plate to the console face plate lighting connector with servo extension cable CD-47/CD-16 (with large hole Pin A on connector matching blank on console). Find two **WHITE WIRES** originating at AMP connector CD-20 on rear of console, one wire terminating in a Delco fitting and one white wire terminating in a **KNIFE** connector. Connect the white wire CD-26 terminating in a knife connector to a positive 14 or 28-volt supply, whichever is applicable, and observe all face plate lights glow.

NOTE

Console translucent material glows very dimly, shield from external light source. If some lights do not glow, replace bulbs and/or console face plate as required. If none of the lights glow, check DC power source and fuse.

15. Disconnect **A+** lead from the knife connector and remove the servo extension cable CD-47/CD-16 from the face plate and the console face plate lighting connector.
16. Attach the **DELCO** fitting from the remaining white wire to the positive side of the power supply.

17. Push the ROLL ENGAGE SWITCH, located on the autopilot console, to the "ON" position and observe that SOLENOID light located on the face of the Power Section Test Box glows.

NOTE

If solenoid light glows, proceed to Step 18. If solenoid light DOES NOT glow, recheck power supply voltage and wiring harness for correct connections. If solenoid light still does not glow with cables properly connected and proper voltage applied, turn off power supply and proceed to Step 21.

18. Disconnect A+ lead. The roll engage switch should disengage.
19. Connect A+ lead. Push ALL switches to the ON position. Ascertain that the Roll, Heading, Pitch and ALT Switches engage. If switches fail to engage, replace console.
20. Push all console switches to the OFF position except the ROLL ENGAGE SWITCH and proceed to Step 26.
21. Find CONSOLE SUBSTITUTE TEST BOX. Place the POWER SELECTOR SWITCH, located on the lower left hand corner of the Console Substitute Test Box, to the DOWN or "OFF" position.
22. Remove AMP connector CD-20 from the rear of the console and plug it into the CD-20 receptacle located on the top left corner of the Console Substitute Test Box.
23. Immediately to the right of the CD-20 AMP connector, find a 14 or 28-volt SLIDE SWITCH. Place this switch in the proper voltage position to agree with VOLTAGE SELECTOR SWITCH on top plate of amplifier, also the selector switch on the lower left hand corner of the Power Section Test Box.
24. Reapply voltage from power supply and place POWER SELECTOR SWITCH on lower left hand side of Console Substitute Box to the "ON" position. Observe SOLENOID LIGHT now glows on Power Section Test Box.

NOTE

If light DOES GLOW, replace autopilot CONSOLE. If light DOES NOT glow, replace autopilot AMPLIFIER. If component is replaced return to beginning of test sequence.

25. Disconnect AMP connector CD-20 from Console Substitute Test Box and connect it to the console.
26. Depress RED BUTTON on lower right corner of Power Section Test Box labeled INPUT VOLTAGE. Test box needle should deflect to the right and read 12-14 volts DC or 24-28 volts DC.
27. Rotate SELECTOR KNOB, lower center of Power Section Test Box, CLOCKWISE to the full right position labeled "RES."
28. Rotate the ROLL COMMAND KNOB, located on left side of the console, full left and observe voltmeter on Power Section Test Box points LEFT to read approximately 12-volts.
29. Rotate ROLL COMMAND KNOB full right and observe voltmeter on Power Section Test Box indicates right approximately 12 volts. Proceed to Step 31 if correct indication is recorded.

NOTE

If voltmeter does not deflect when rotating roll command knob, recheck that heading switch on the console is pushed to the "OFF" position.

30. If needle of voltmeter on Power Section Test Box still does not respond to the roll command knob rotation, substitute the console with the Console Substitute Box. Remove the CD-20 plug from the rear of console and plug it into the CD-20 receptacle on the Console Substitute Box. Place the **DIRECTIONAL GYRO MANUAL SLIDE SWITCH IN THE MANUAL POSITION**. Make sure the **POWER SWITCH** is in the "ON" position. Rotate the roll manual knob full **RIGHT** and observe if voltmeter on Power Section Test Box points right. Rotate the roll manual knob full **LEFT**, observe if voltmeter on Power Section Test Box points **LEFT**. If **NEEDLE** on voltmeter now **MOVES**, **REPLACE** the **CONSOLE**. If not, replace the **AMPLIFIER**.

31. Make sure large vernier knob on Gyro Substitute Test Box is centered and points to **ZERO** on **TOP SCALE** labeled **ROLL DEGREES**.

32. Push **HEADING SWITCH** on the console to the "ON" position. Rotate the roll command knob on the console full right and left and observe there is **NO** movement of the needle on the Power Section Test Box. If the needle moves, check that **HEADING SWITCH** is in the "ON" position. If needle still moves, console **MUST** be replaced. If there is no needle movement, proceed with next step.

33. Find six adjustment potentiometers located on the front of the console and directly under the trim meter. (Refer to Figure 5-1.) Insert **SMALL** slot head screwdriver in **SECOND HOLE FROM LEFT** and adjust the roll centering adjustment until needle of voltmeter of Power Section Test Box centers and holds on **ZERO**. If unable to adjust needle to **ZERO** by rotating the adjustment screw, replace console.

CAUTION

When making any adjustment on the AltiMatic IIIC, it is **MANDATORY** to wait a minimum of 30 seconds before taking any readings until the computer has time to digest any new information.

34. With needle holding **ZERO** on Power Section Test Box, push the **HEADING SWITCH**, on the console, to the "OFF" position and observe needle on Power Section Test Box. If needle **DEFLECTS** off of zero, carefully adjust it back to zero by **ROTATING** the **ROLL COMMAND KNOB** on the console, again waiting for the computer to digest the new command.

35. After the needle holds zero by adjusting the roll command knob, press **HEADING SWITCH**, on the console, to the "ON" position and observe **NO CHANGE** occurs on the Test Box Needle Indication.

NOTE

If needle does change, repeat Steps 33 thru 35.

36. With needle holding zero in each mode, observe the physical position of the roll command knob on the autopilot console is straight up \pm approximately 3 degrees. If **ROLL COMMAND KNOB** is out of tolerance, replace console.

37. Press **HEADING SWITCH**, on the console, to the "ON" position.

38. Place **DIRECTIONAL GYRO SELECTOR CONTROL KNOB**, located on the lower right hand corner of the Gyro Substitute Test Box, to the right hand 45 degree position or full **CLOCKWISE**. Observe needle deflects **RIGHT** on the Power Section Test Box.

39. Rotate **LARGE VERNIER KNOB** on Gyro Substitute Test Box **CLOCKWISE** to the right hand 20 degree position reading the **TOP SCALE** labeled **ROLL DEGREES**.

NOTE

Large increments represent 5 degrees each.

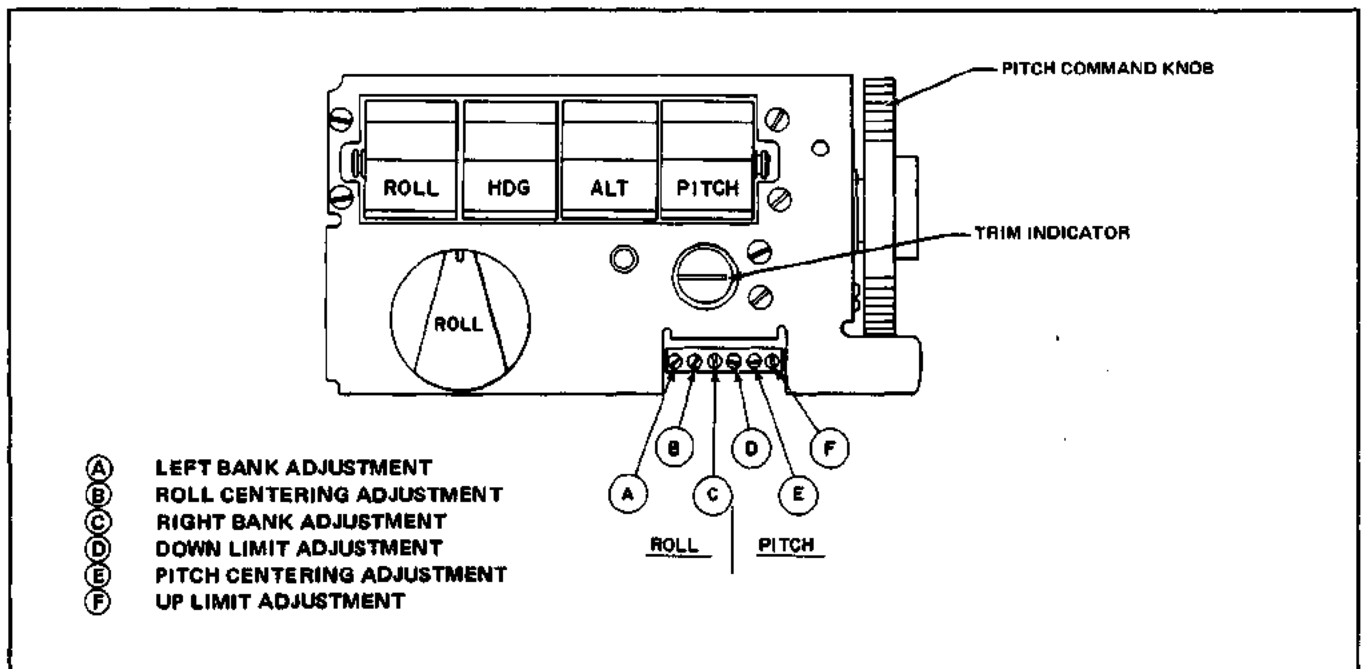

Figure 5-1. AltiMatic IIC Console

40. With small slot head screwdriver, adjust the potentiometer located inside the THIRD HOLE from the left DIRECTLY below the trim meter on the console to center the needle on the Power Section Test Box to zero. If unable to adjust to zero, replace console.

41. Leaving the HEADING SWITCH "ON", rotate the DIRECTIONAL GYRO SELECTOR CONTROL KNOB, located on lower right hand corner of the Gyro Substitute Test Box, to the LEFT HAND 45 degree position or full COUNTERCLOCKWISE. Observe needle on Power Section Test Box deflects far left on scale.

42. Rotate LARGE VERNIER KNOB ON Gyro Substitute Test Box COUNTERCLOCKWISE to the LEFT HAND 20 degree position, reading the TOP SCALE labeled ROLL DEGREES. With small slot head screwdriver, adjust the POTENTIOMETER inside the LEFT HAND HOLE below the trim meter on the console to center the needle on the Power Section Test Box to zero. If unable to adjust to zero, replace console.

43. Rotate DIRECTIONAL GYRO SELECTOR KNOB, located on lower right hand corner of Gyro Substitute Test Box to the LEFT HAND 10 degree position. Observe needle on Power Section Test Box moves to the RIGHT.

44. Rotate the LARGE VERNIER KNOB on the Gyro Substitute Test Box CLOCKWISE to center the needle on Power Section Test Box, again waiting for the computer to digest the new information until the needle stays centered after at least a 30 second wait.

45. Read the degree of bank in the Gyro Substitute Test Box from the TOP SCALE labeled ROLL DEGREES. The pointer must be between 8 and 13 degrees of bank angle. IF OUT OF TOLERANCE, REPLACE AMPLIFIER.

46. Rotate the DIRECTIONAL GYRO SELECTOR KNOB, located at the lower right hand corner of the Gyro Substitute Test Box, to the RIGHT HAND 10 degree position. Observe needle of Power Section Test Box deflects to the RIGHT.

47. Rotate the LARGE VERNIER KNOB, located on the Gyro Substitute Test Box, CLOCKWISE to center the needle of the Power Section Test Box. Again wait for the computer to digest the new information until the needle stays centered after at least a 30 second wait.

48. Read the degree of bank on the Gyro Substitute Test Box from the TOP SCALE labeled ROLL DEGREES. The pointer must be between 8 and 13 degrees of bank angle. IF OUT OF TOLERANCE, REPLACE AMPLIFIER.

49. Push the HEADING SWITCH, on the console, to the "OFF" position. Rotate the ROLL COMMAND KNOB full right. Observe needle on Power Section Test Box indicates right.

50. Rotate the LARGE VERNIER KNOB on the Gyro Substitute Test Box CLOCKWISE to center the needle on Power Section Test Box, again waiting for the computer to digest the new information until the needle stays centered after at least a 30 second wait.

51. Read the degree of bank on the Gyro Substitute Test Box TOP SCALE labeled ROLL DEGREES. Bank MUST be 28 degrees \pm 3 degrees. IF OUT OF TOLERANCE, REPLACE CONSOLE.

52. Rotate the ROLL COMMAND KNOB full LEFT. Rotate the LARGE VERNIER KNOB on the Gyro Substitute Test Box COUNTERCLOCKWISE to center the needle on the Power Section Test Box.

53. Read the degree of bank on the Gyro Substitute Test Box on the TOP SCALE labeled ROLL DEGREES. Bank MUST be 28 degrees \pm 3 degrees. IF OUT OF TOLERANCE, REPLACE CONSOLE.

54. Recenter ROLL COMMAND KNOB to the center position. Rotate the POWER SECTION TEST BOX SELECTOR KNOB, turning COUNTERCLOCKWISE to the CENTER or "OFF" position. Rotate the DIRECTIONAL GYRO SELECTOR KNOB, located on lower right hand corner of Gyro Substitute Test Box, to the ZERO or straight "UP" position.

55. Push ROLL ENGAGE SWITCH to the "OFF" position.

56. Refer to the following paragraph for Roll Threshold Adjustment Procedure.

5-3. ROLL THRESHOLD ADJUSTMENT FOR ALTIMATIC IIIC.

Remove the base plate from the bottom of the amplifier to gain access to the roll threshold adjustment potentiometer. (Refer to Figure 5-2.)

CAUTION

Threshold adjustments are to be accomplished with a 12-volt calibrated bench set-up. When adjusting 28-volt systems, convert bench set-up to 12-volt configuration until threshold adjustment procedure is completed. Verify all switches are returned to the 28-volt position prior to reinstallation in 28-volt aircraft. Setting of the large vernier control knob on the Gyro Substitute Test Box is critical when doing this adjustment procedure.

1. Disconnect the AMP connector CD-20 from the rear of the console and set the console aside.

2. Find CONSOLE SUBSTITUTE TEST BOX. Place the POWER SELECTOR SWITCH, located on the lower left hand corner of the Console Substitute Test Box, to the DOWN or "OFF" position.

3. Plug the AMP connector CD-20 into the receptacle, located on the top left corner of the Console Substitute Test Box.

4. Immediately to the right of the AMP connector CD-20 on the Console Substitute Test Box, find the (14 or 28-volt) SLIDE SWITCH. Place this switch in the 14-volt position.

5. Place the DIRECTIONAL GYRO slide switch, located on lower left of Console Substitute Test Box, in the UP or D.G. position.

6. Rotate SELECTOR KNOB, lower center of Power Section Test Box, CLOCKWISE to the "RES" position.

7. Ascertain the DIRECTIONAL GYRO SELECTOR KNOB, located on lower right hand corner of Gyro Substitute Test Box, is in the ZERO or straight "UP" position.

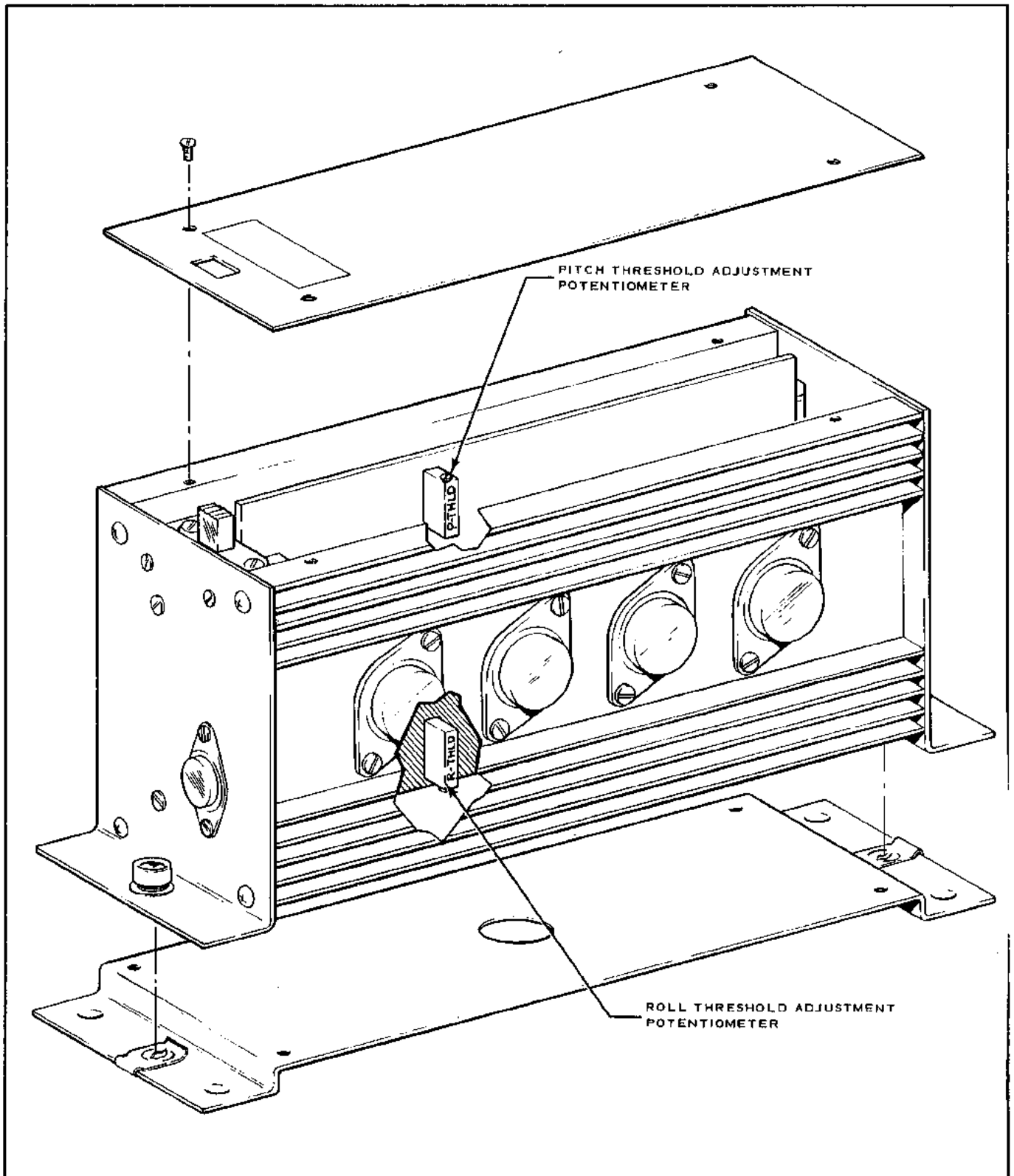

Figure 5-2. AltiMatic IIC, 1C515-1/1C515-3 Amplifier
Threshold Adjustment Potentiometers

8. Rotate the **LARGE VERNIER CONTROL KNOB** on Gyro Substitute Test Box to the centered **ZERO** position reading the **TOP SCALE** labeled **ROLL DEGREES**.

9. Place the **POWER SELECTOR SWITCH** on lower left hand side of Console Substitute Test Box to the "ON" position. Observe **SOLENOID LIGHT** now glows on Power Section Test Box.

10. Rotate the **ROLL TRIM KNOB** on Console Substitute Test Box as required to center the needle on the Power Section Test Box to **ZERO**.

11. Rotate the **LARGE VERNIER CONTROL KNOB** on Gyro Substitute Test Box **CLOCKWISE** for a one (1) degree right bank.

12. Observe voltmeter on Power Section Test Box and record meter reading. (Refer to Figure 5-3 for enlarged view of voltmeter.)

13. Rotate the **LARGE VERNIER CONTROL KNOB** on Gyro Substitute Test Box, **COUNTERCLOCKWISE** for a one (1) degree left bank.

14. Observe voltmeter on Power Section Test Box and record meter reading. Average the meter readings obtained and refer to Table V-I for correct voltage settings.

15. If voltage setting is correct proceed to next step. If voltage setting is incorrect find the Roll Threshold Adjustment Potentiometer, located on the lower section of the amplifier printed circuit board (refer to Figure 5-2), and adjust to obtain an average of the voltage settings listed in Table V-I by repeating Steps 11 thru 14.

16. Rotate the Power Section Test Box Selector Knob **COUNTERCLOCKWISE** to the center or "OFF" position.

17. Place the **POWER SELECTOR SWITCH** on lower left hand side of Console Substitute Test Box to the "OFF" position.

18. Refer to the following paragraph for the Pitch Bench Set-up.

5-4. PITCH BENCH SET-UP FOR ALTIMATIC IIIC.

1. Disconnect AMP connector CD-20 from the Console Substitute Test Box and connect it to the console.

2. Unplug CD-47 connector attached to the face of the Power Section Test Box Amplifier receptacle. Set aside the CD-47 that was removed and in its place install the 4-pin male CD-16 connector.

3. Plug the 5-pin female CD-10 connector into the 5-pin male connector on right hand side of the Console Substitute Box.

4. Rotate the **LARGE VERNIER CONTROL KNOB** on the Gyro Substitute Test Box to read zero on the **BOTTOM SCALE** labeled **PITCH DEGREES**.

5. Immediately below the vernier control knob, find a **SLIDE SWITCH** labeled **ROLL** and **PITCH**. Place this switch in the "DOWN" or **PITCH** position.

6. Ascertain that the **VOLTAGE SELECTOR SWITCHES** of all the components are in the same position (14 or 28-volts DC) as the bench power supply. This will insure proper autopilot operation and prevent damage to the components.

7. Engage the **ALTIMATIC IIIC** by pushing the **ROLL ENGAGE SWITCH**, on the console, to the "ON" position. **DO NOT EXPECT SOLENOID LIGHT TO GLOW**.

8. Push **PITCH ENGAGE SWITCH**, on the console, to the "ON" position and observe solenoid light, located on the face of the Power Section Test Box, glows. If light glows, proceed with Step 15.

a. If solenoid light does not glow, recheck that CD-16 connector is installed in the receptacle on the face of the Power Section Test Box labeled Amplifier.

b. If solenoid light does not glow, recheck power supply voltage and wiring harness for correct connections.

c. If solenoid light still does not glow with cables properly connected and proper voltage applied, turn off power supply and proceed with next step.

9. Place the POWER SELECTOR SWITCH, located on the lower left hand corner of the Console Substitute Box to the DOWN or "OFF" position.

10. Remove the AMP connector CD-20 from the rear of the console and plug it into the CD-20 receptacle located on the top left corner of Console Substitute Test Box.

11. Immediately to the right of the CD-20 AMP connector, find a 14 or 28-volt SLIDE SWITCH. Ascertain the switch is in the proper voltage position to agree with both the voltage selector switch on top plate of amplifier and the selector switch on the lower left corner of the Power Section Test Box.

12. Reapply voltage from power supply and place power selector switch on lower left hand side of Console Substitute Test Box to the UP or "ON" position. Observe solenoid light now glows on Power Section Test Box.

NOTE

If light DOES glow, replace autopilot CONSOLE. If light DOES NOT glow, replace autopilot AMPLIFIER.

13. Place the POWER SELECTOR SWITCH, located on the lower left hand corner of the Console Substitute Box to the DOWN or "OFF" position.

14. Unplug the AMP connector CD-20 attached to the Console Substitute Test Box and connect it to the CD-20 receptacle on the rear of the console.

15. Rotate the selector knob, located on the face of the Power Section Test Box, full CLOCKWISE to the "RES" position.

16. Make sure LARGE VERNIER CONTROL KNOB on Gyro Substitute Test Box is reading ZERO on the BOTTOM SCALE labeled PITCH DEGREES.

17. Rotate the PITCH COMMAND DISC up on AltiMatic Console, for a full DOWN command and observe needle of Power Section Test Box deflects LEFT.

18. Rotate the PITCH COMMAND DISC down for a full UP command and observe needle of Power Section Test Box deflects to the RIGHT.

19. Recenter PITCH COMMAND DISC so that the indice calls for a level attitude.

20. With a small slot head screwdriver adjust the FIFTH POTENTIOMETER from the left, located directly below the trim meter on the console, to center the needle on the Power Section Test Box to ZERO. (Refer to Figure 5-1.)

NOTE

Keep in mind you MUST WAIT 30 SECONDS for the autopilot to digest any new information.

21. Rotate the LARGE VERNIER CONTROL KNOB on Gyro Substitute Test Box COUNTERCLOCKWISE to indicate 7 degrees nose down, reading BOTTOM SCALE labeled PITCH DEGREES.

22. Rotate PITCH COMMAND DISC up for a full "DOWN" command.

23. With a small slot head screwdriver adjust the FOURTH POTENTIOMETER from the left, located directly below the trim meter on the console, to center the needle on the Power Section Test Box to ZERO. If unable to adjust to zero, replace console.

24. Rotate the LARGE VERNIER CONTROL KNOB on Gyro Substitute Test Box CLOCKWISE to indicate 10 degrees nose up reading BOTTOM SCALE labeled PITCH DEGREES.

25. Rotate PITCH COMMAND DISC down for a full "UP" command.

26. With a small slot head screwdriver adjust the SIXTH POTENTIOMETER from the left, located directly below the trim meter on the console, to center the needle on the Power Section Test Box to ZERO. If unable to adjust to zero, replace console.

27. Push the ALT ENGAGE SWITCH, on the console, to the "ON" position.

28. Rotate the LARGE VERNIER CONTROL KNOB on Gyro Substitute Test Box COUNTERCLOCKWISE until the needle of the Power Section Test Box returns to ZERO.

29. Rotate PITCH COMMAND DISC down for a full "UP" command and then up for a full "DOWN" command and note little change occurs on Power Section Test Box meter. Should a large amount of needle movement be present during Pitch Command Disc movement recheck ALT ENGAGE SWITCH, located on the console, is in the "ON" position. (If a large amount of needle movement is still present during Pitch Command Disc movement, replace console.) Recenter Pitch Command Disc.

30. Push all console switches to the "OFF" position.

31. Refer to the following paragraph for Pitch Threshold Adjustment Procedure.

5-5. PITCH THRESHOLD ADJUSTMENT FOR ALTIMATIC IIIC.

Remove the cover plate from the top of the amplifier to gain access to the Pitch Threshold Adjustment Potentiometer. (Refer to Figure 5-2.)

CAUTION

Threshold adjustments are to be accomplished with a 12-volt calibrated bench set-up. When adjusting 28-volt systems, convert bench set-up to 12-volt configuration until threshold adjustment procedure is completed. Verify all switches are returned to the 28-volt position prior to reinstallation in 28-volt aircraft. Setting of the large vernier control knob on the Gyro Substitute Test Box is critical when doing this adjustment procedure.

1. Disconnect the AMP connector CD-20 from the rear of the console and set the console aside.

2. Find CONSOLE SUBSTITUTE TEST BOX. Place the POWER SELECTOR SWITCH, located on the lower left hand corner of the Console Substitute Test Box, to the DOWN or "OFF" position.

3. Plug the AMP connector CD-20 into the receptacle, located on the top left corner of the Console Substitute Test Box.

4. Immediately to the right of the AMP connector CD-20 on the Console Substitute Test Box, find the (14 or 28-volt) SLIDE SWITCH. Place this switch in the 14-volt position.

5. Place the ALT. CONTROL slide switch, located on lower left of Console Substitute Test Box, in the UP or Alt. Control position.

6. Place the ALTITUDE CONTROL KNOB, located on upper right of Console Substitute Test Box, to the straight up or 12 o'clock position.

7. Rotate the SELECTOR KNOB, lower center of Power Section Test Box, CLOCKWISE to the "RES" position.

8. Rotate the LARGE VERNIER CONTROL KNOB on Gyro Substitute Test Box to the ZERO position on the BOTTOM SCALE labeled PITCH DEGREES.

9. Immediately below the large vernier control knob on Gyro Substitute Test Box, find a SLIDE SWITCH labeled ROLL and PITCH. Place this switch in the "DOWN" or PITCH position.

10. Place the POWER SELECTOR SWITCH on lower left hand side of Console Substitute Test Box to the "ON" position. Observe SOLENOID LIGHT now glows on Power Section Test Box.

11. Rotate the PITCH TRIM KNOB on Console Substitute Test Box as required to center the needle on Power Section Test Box to ZERO.
12. Rotate LARGE VERNIER CONTROL KNOB on Gyro Substitute Test Box COUNTERCLOCKWISE to indicate three-quarters (3/4) degree nose down, reading BOTTOM SCALE labeled PITCH DEGREES.
13. Observe voltmeter on Power Section Test Box and record meter reading. (Refer to Figure 5-3 for enlarged view of voltmeter.)
14. Rotate the LARGE VERNIER CONTROL KNOB on Gyro Substitute Test Box CLOCKWISE to indicate three-quarters (3/4) degree nose up, reading BOTTOM SCALE labeled PITCH DEGREES.
15. Observe voltmeter on Power Section Test Box and record meter reading. Average the meter readings obtained and refer to Table V-II for correct voltage settings.
16. If voltage setting is correct proceed to next step. If voltage setting is incorrect find the Pitch Threshold Adjustment Potentiometer, located on upper section of amplifier printed circuit board, (refer to Figure 5-2) and adjust to obtain an average of the voltage setting listed in Table V-II by repeating Steps 12 thru 15.
17. Place the POWER SELECTOR SWITCH on Console Substitute Test Box to the "OFF" position.
18. Disconnect test equipment and associated cables and reinstall the components in the airplane.
19. Proceed with ground checks and flight adjustments.

TABLE V-I. ROLL THRESHOLD

AIRCRAFT MODEL	NOMINAL THRESHOLD VOLTAGE
PA-23-250	3.0 volts
PA-28RT-201;-201T	2.5 volts
PA-31-310;-325	2.5 volts
PA-31-350	2.5 volts
PA-31P	2.5 volts
PA-32-260;-300, PA-32R-300 & PA-32RT-300;-300T	2.5 volts
PA-32-301;-301T & PA-32R-301;-301T	2.5 volts
PA-34-200T	2.5 volts
PA-44-180	2.5 volts
PA-44-180T	2.5 volts

TABLE V-II. PITCH THRESHOLD

AIRCRAFT MODEL	THRESHOLD VOLTAGE
PA-23-250	4.0 volts
PA-28RT-201;-201T	4.0 volts
PA-31-310	3.0 volts
PA-31-325	4.0 volts
PA-31-350	4.0 volts
PA-31P	4.0 volts
PA-32-260;-300	3.5 volts
PA-32R-300 & PA-32RT-300;-300T	4.0 volts
PA-32-301;-301T & PA-32R-301;-301T	4.0 volts
PA-34-200T	4.0 volts
PA-44-180	4.1 volts
PA-44-180T	4.1 volts

5-6. ALTIMATIC IIC GROUND CHECK WITHOUT RADIO COUPLER (ROLL).

1. Remove the console face plate by removing the roll command knob and the four face plate mounting screws. After removing the face plate, reinstall the roll command knob to facilitate accomplishing in-flight adjustments.

2. Center the roll command knob and position HDG and ROLL engage switches to the "OFF" position.

3. Start airplane engine to obtain gyro stability.

4. Place the airplane control wheel to approximately neutral aileron or level flight position. Push roll engage switch to the "ON" position. Move control wheel right and left to check for servo engagement.

5. Rotate the roll command knob to the right and to the left and observe that the airplane control wheel moves in the correct direction.

NOTE

The airplane control wheel can be stopped in any position and will not return to level position by centering the roll command knob. The airplane control wheel will remain stationary at the time the roll command knob is approximately centered or at its zero electrical output position.

6. Center the Heading Bug of the Directional Gyro or Horizontal Situation Indicator and push console HDG SWITCH "ON." WITH CONSOLE HEADING SWITCH PUSHED TO THE "ON" POSITION, THE ROLL COMMAND KNOB ON THE CONSOLE BECOMES INOPERATIVE.

7. Set the Heading Bug for a heading change to the right, observe control wheel should turn right. Make same check to the left. Return the Heading Bug to existing aircraft heading.

8. Push ROLL ENGAGE SWITCH TO THE "OFF" position. Rotate the CONTROL WHEEL right and left and observe servo disengaged.

9. Refer to paragraph 5-13 and proceed with AltiMatic IIC Pitch Ground Check.

5-7. ALTIMATIC IIC FLIGHT ADJUSTMENTS WITHOUT RADIO COUPLER (ROLL).

1. The aircraft shall be loaded to or near its AFT-C.G. LIMIT for flight set-up to assure all flight profiles are met. Consult AIRCRAFT WEIGHT AND BALANCE DATA TO ENSURE FUEL BURN DURING FLIGHT SET-UP DOES NOT PLACE AIRCRAFT OUTSIDE THE C.G. ENVELOPE. Previous Altimatic series Autopilots do not require this loading. (Refer to Flight Manual for proper power settings.)

NOTE

For adjusting descent, 19 inches of mercury manifold pressure must be used on all airplanes except the PA-31-310, PA-31-325 and PA-31-350 which must be adjusted at 20 inches of mercury and the PA-31P which must be adjusted at 25 inches of mercury.

2. MAKE CERTAIN RUDDER TRIM IS ADJUSTED TO CENTER THE BALL. IF RUDDER IS INCORRECTLY TRIMMED, THE ALTIMATIC WILL FLY THE AIRPLANE WITH A WING LOW TO COMPENSATE FOR THE OUT OF TRIM RUDDER.

NOTE

SMOOTH AIR IS REQUIRED.

3. Push console HDG ENGAGE SWITCH to the "ON" position. Set the HEADING BUG to the aircraft heading.

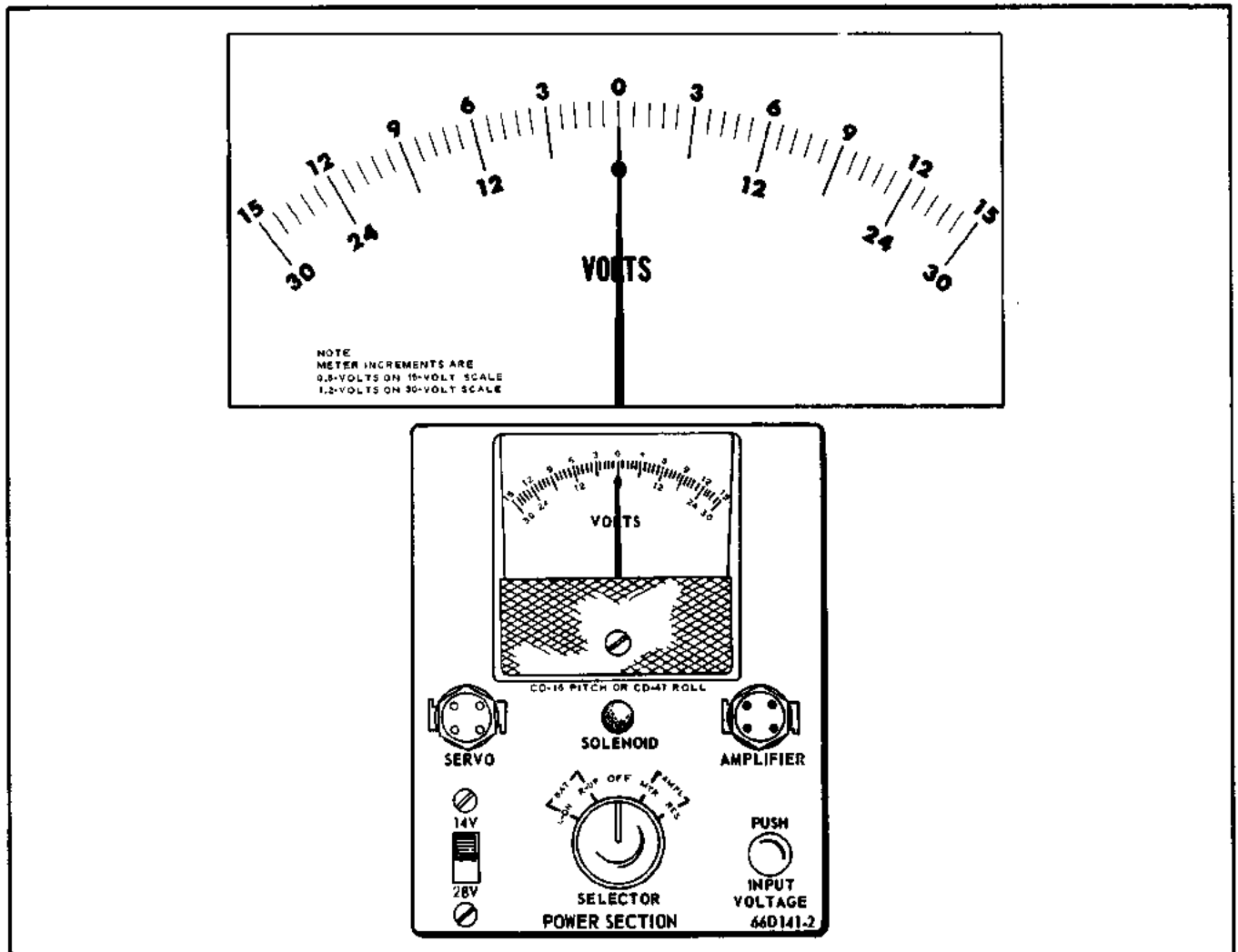

Figure 5-3. Power Section Test Box

4. Push ROLL ENGAGE SWITCH to the "ON" position. If the airplane does not maintain the selected heading, adjust roll centering adjustment as necessary so that airplane remains on selected heading.
5. Set the HEADING BUG 150 degrees to the left of heading and observe the angle of bank on the artificial horizon. Adjust the left bank screw of the console to obtain 20 degree bank. Rotating the adjustment screw clockwise will increase the bank angle.

CAUTION

Make certain HEADING BUG does not get within 25 degrees of the airplane's heading until the adjustment is completed.

6. Set the HEADING BUG 150 degrees to the RIGHT and observe the angle of bank. Adjust the right bank adjustment screw of the console to obtain a 20 degree bank. Rotating adjustment screw CLOCKWISE INCREASES bank angle.

CAUTION

Make certain HEADING BUG does not get within 25 degrees of the airplane's heading until the adjustment is completed.

7. Allow the airplane to become established on the selected heading. Observe that autopilot maintains a selected heading within ± 2 degrees. If not, repeat Step 4.

NOTE

Always recheck bank settings after adjusting roll centering.

8. Make certain roll knob is centered. Push console HDG ENGAGE SWITCH to the "OFF" position and observe that the airplane flies wings level within ± 2 degrees.
9. Turn the roll command knob full LEFT and observe that airplane banks LEFT 28 ± 3 degrees.
10. Turn the roll command knob full RIGHT and observe that airplane banks RIGHT 28 ± 3 degrees.
11. Refer to paragraph 5-15 and proceed with AltiMatic IIIC Pitch Flight Check Adjustments.

5-8. BENCH SET-UP AND ADJUSTMENTS FOR ALTIMATIC IIIC CONSOLE AND 1C515-1/1C515-3 AMPLIFIER WITH RADIO COUPLER.

NOTE

If either the console or the amplifier is replaced, the console must be set up through its complete adjustment procedure.

- a. The following equipment will be required from the Autopilot Test Kit, Piper P/N 753 439 (66D141).
 1. Gyro Substitute Test Box 66D141-1.
 2. Power Section Test Box 66D141-2.
 3. Console Substitute Box 66D141-3.
 4. Radio Coupler Tester 66D141-4.

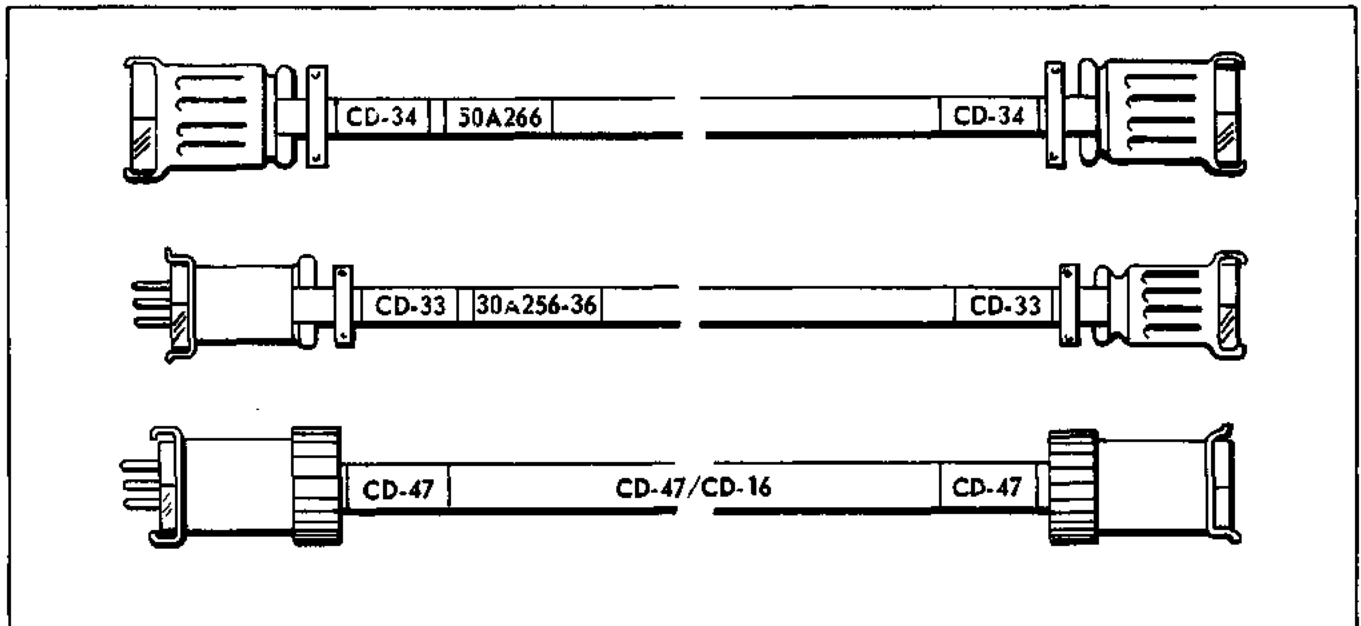

Figure 5-4. Extension Test Cables

5. AltiMatic III test harness, identified by a large 30-pin AMP connector feeding through five connecting cables labeled CD-16, CD-18, CD-20, CD-33 and CD-47. This cable also contains two white wires, one wire terminating at a Delco fitting labeled CD-27 and the other terminating at a knife connector labeled CD-26.

6. Servo Extension Cable CD-47/CD-16 with a male CD-47 connector on one end and a female CD-47 connector on the other end.

7. One radio extension cable approximately 3 feet long with a female 9-pin connector labeled CD-34 on each end.

8. Two amplifier extension cables, approximately 3 feet long, with a female 7-pin connector labeled CD-33 on one end and a male 7-pin connector also labeled CD-33 at the other end.

9. One Coupler Test Box power cable, approximately 3 feet long, with a RED and BLACK alligator clip on one end and a red and black male plug on the other end.

b. BENCH SET-UP AND ADJUSTMENT PROCEDURES ARE AS FOLLOWS:

1. Remove the console face plate by removing the roll command knob and four face plate mounting screws. After removing the face plate, reinstall the roll command knob to facilitate accomplishing bench set-up adjustments.

2. Determine that the VOLTAGE SELECTOR SWITCHES, located on top plate of amplifier and the right side of the console are in the same position (14 or 28-volts DC) as the bench power supply. This will insure proper autopilot operation and prevent damage to the components.

3. Hold the AMPLIFIER with 30-pin amplifier board facing you. Plug large 30-pin AMP connector of the test harness onto the amplifier board with the cable fanning out to your right. Identification placard on the amplifier should be visible.

4. Plug AMP connector CD-20 from the test harness onto the CD-20 receptacle located on the rear of the console.

5. Check that all WHITE ENGAGE SWITCHES are pushed to their "OFF" positions on the autopilot console.

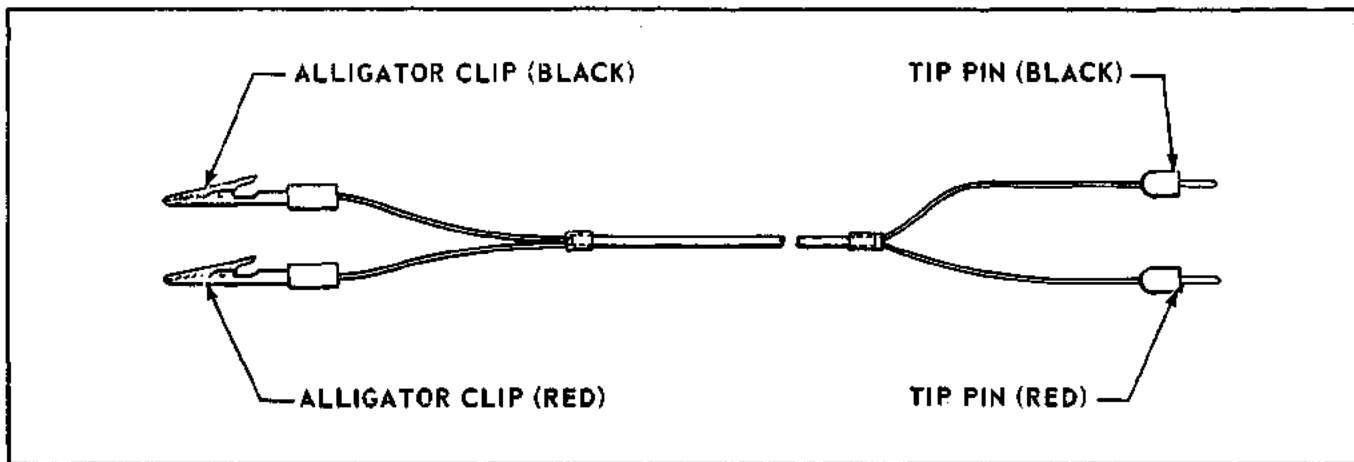

Figure 5-5. Radio Coupler Power Cable

6. Plug the 4-pin male CD-47 connector from the test harness into the female 4-pin receptacle located on the right hand side of the Power Section Test Box. This receptacle is labeled AMPLIFIER. On the Power Section Test Box, find the VOLTAGE SELECTOR SWITCH on the lower left hand corner and insure that this switch is positioned to match the bench power supply and the amplifier voltage selector switch in Step 2. (14 or 28-volts DC).

7. Rotate SELECTOR KNOB on Power Section Test Box to the CENTER or "OFF" position.

8. Connect the CD-33 CABLE coming from the large AMP connector of the amplifier, into the male 7-pin connector located on the face of the Radio Coupler Test Box at the upper left hand corner (Labeled AMPLIFIER).

9. Find the RADIO SIGNAL SUBSTITUTE KNOB located on the RADIO COUPLER TEST BOX, immediately to the right of the bottom omni meter. MAKE SURE THIS RADIO SIGNAL KNOB IS IN THE "IN" POSITION.

10. Find the VOLTAGE SELECTOR SWITCH located immediately to the left of the Red and Black DC input terminals on the face of the Radio Coupler Test Box. Place this VOLTAGE SELECTOR SWITCH in the proper voltage position.

11. Connect one of the two CD-33 EXTENSION CABLES to the 7-pin female connector LABELED COUPLER, located on the face of the Radio Coupler Test Box.

12. Connect the 7-pin female connector at the other end of the CD-33 cable to the 7-pin male connector located on the rear of the radio coupler LABELED CD-33.

13. Find the CD-34 EXTENSION CABLE with female connectors at both ends. Connect one end of this cable to the male 9-pin connector located on the rear of the radio coupler LABELED CD-34. Connect the other female 9-pin connector CD-34 on this cable to the male 9-pin connector located on the face of the Radio Coupler Test Box, LABELED RADIO, CD-34.

14. Connect the short cable coming from inside the radio coupler with a 5-pin female connector LABELED CD-33 on the end to the 5-pin male connector located on the face of the Gyro Substitute Test Box.

15. Connect the CD-18 cable coming from the large AMP plug at the amplifier to the 7-pin male connector located on the face of the Gyro Substitute Test Box LABELED CD-18.

16. Rotate LARGE VERNIER CONTROL KNOB on face of Gyro Substitute Test Box to the CENTER or "ZERO" position on the TOP SCALE labeled ROLL DEGREES.

17. Below the large vernier knob on the Gyro Substitute Box, find a SLIDE SWITCH labeled "ROLL" and "PITCH." Place this slide switch in the "UP" or "ROLL" position.

18. Immediately to the right of the slide switch, find a DIRECTIONAL GYRO SELECTOR KNOB.

19. Place this DIRECTIONAL GYRO SELECTOR KNOB to the CENTER or "ZERO" position.
20. Find the RADIO COUPLER POWER CABLE with the RED and BLACK alligator clips on one end. (Refer to Figure 5-5.) Plug the RED and BLACK MALE PLUGS of the Coupler Test Box Power Cable into the red and black female receptacles located on the face of the Radio Coupler Test Box LABELED DC INPUT.
21. Connect the RED and BLACK ALLIGATOR CLIPS to a 14 or 28-volt DC power supply, whichever is applicable, FUSED at 3 AMPS USED TO CHECK COUPLER LIGHTS ONLY.

CAUTION

OBSERVE POLARITY.

22. Make sure all white buttons on the console are PUSHED to their "OFF" position.
23. Set aside the remaining cables labeled CD-16 and CD-10. Connect a ground lead to the bottom mounting flange of the AltiMatic IIIC amplifier.

CAUTION

DO NOT place the ground lead near the output transistors located between the cooling fins along the side of the amplifier.

24. Connect the face plate to the console face plate lighting connector with servo extension cable CD-47/CD-16 (with large hole Pin A on connector matching blank on console). Find two WHITE WIRES originating at AMP connector CD-20 on rear of console, one wire terminating in a Delco fitting and one white wire terminating in a knife connector. Connect the white wire CD-26 terminating in a knife connector to a positive 14 or 28-volt supply, whichever is applicable, and observe all face plate lights glow.

NOTE

Console translucent material glows very dimly, shield from external light source. If some lights do not glow, replace bulbs and/or console face plate as required. If none of the lights glow, check DC power source and fuse.

25. Disconnect A+ lead from the knife connector and remove the servo extension cable CD-47/CD-16 from the face plate and the console face plate lighting connector.
26. Attach the DELCO fitting from the remaining white wire to the positive side of the power supply.
27. Push the ROLL ENGAGE SWITCH, located on the autopilot console, to the "ON" position and observe that SOLENOID light located on the face of the Power Section Test Box glows.

NOTE

If solenoid light glows, proceed to Step 28. If solenoid light DOES NOT glow, recheck power supply voltage and wiring harness for correct connections. If solenoid light still does not glow with cables properly connected and proper voltage applied, turn off Power Supply and proceed to Step 31.

28. Disconnect A+ lead. The roll engage switch should disengage.
29. Connect A+ lead. Push ALL console switches to the ON position. Ascertain that the Roll, Heading, Pitch and ALT Switches engage. If switches fail to engage, replace console.
30. Push all console switches to the OFF position except the ROLL ENGAGE SWITCH and proceed to Step 36.
31. Find CONSOLE SUBSTITUTE TEST BOX. Place the POWER SELECTOR SWITCH, located on the lower left hand corner of the Console Substitute Test Box, to the DOWN or "OFF" position.
32. Remove AMP connector CD-20 from the rear of the console and plug it into the CD-20 receptacle located on the top left corner of the Console Substitute Test Box.
33. Immediately to the right of the AMP connector CD-20 find a 14 or 28-volt SLIDE SWITCH. Place this switch to the proper voltage position to agree with VOLTAGE SELECTOR SWITCH on the top plate of the amplifier, also the selector switch on the lower left hand corner of the Power Section Test Box.
34. Reapply voltage from power supply and place POWER SELECTOR SWITCH on lower left hand side of Console Substitute Box to the "ON" position. Observe SOLENOID LIGHT now glows on Power Section Test Box.

NOTE

If light DOES glow, replace autopilot CONSOLE. If light DOES NOT glow, replace autopilot AMPLIFIER. If component is replaced return to beginning of test sequence.

35. Disconnect AMP connector CD-20 from Console Substitute Test Box and connect it to the console.
36. Depress RED BUTTON on lower right corner of Power Section Test Box labeled INPUT VOLTAGE. Test box needle should deflect to the right and read 12-14 volts DC or 24-28 volts DC.
37. Rotate SELECTOR KNOB, lower center of Power Section Test Box, CLOCKWISE to the full right position labeled "RES."
38. Rotate the ROLL COMMAND KNOB, located on left side of the console, full left and observe voltmeter on Power Section Test Box points LEFT to read approximately 12-volts.
39. Rotate ROLL COMMAND KNOB full right and observe voltmeter on Power Section Test Box indicates right approximately 12-volts. Proceed to Step 41 if correct indication is recorded.

NOTE

If voltmeter DOES NOT deflect when rotating roll command knob, recheck that heading switch, on the console, is pushed to the "OFF" position.

40. If needle of voltmeter on Power Section Test Box still does not respond to the roll command knob rotation, substitute the console with Console Substitute Box. Remove the CD-20 plug from the rear of console and plug it into the CD-20 receptacle on the Console Substitute Box. Place the DIRECTIONAL GYRO MANUAL SLIDE SWITCH in the MANUAL POSITION. Make sure the POWER SWITCH is in the "ON" position. Rotate the roll manual knob full RIGHT and observe if voltmeter on Power Section Test Box points RIGHT. Rotate the roll manual knob full LEFT. Observe if voltmeter on Power Section Test Box points LEFT. If needle on voltmeter now MOVES, REPLACE the CONSOLE. If not, replace the AMPLIFIER.
41. Make sure the large vernier knob on Gyro Substitute Test Box is centered and points to ZERO on TOP SCALE labeled ROLL DEGREES.

42. Place radio coupler SELECTOR SWITCH to the LOC/NORM mode and push HDG ENGAGE SWITCH to "ON" position.
43. Depress the RED BUTTON on rear of the radio coupler.
44. Find six adjustment potentiometers located on the front of the console and directly under the trim meter. (Refer to Figure 5-5.) While holding IN the RED BUTTON on rear of radio coupler, insert small slot head screwdriver in SECOND HOLE FROM LEFT and adjust roll centering adjustment until needle of voltmeter of Power Section Test Box centers and holds on ZERO. If unable to adjust needle to ZERO by rotating the adjustment screw, replace console.

CAUTION

When making any adjustment on the AltiMatic IIC, it is MANDATORY to wait a minimum of 30 seconds before taking any readings until the computer has time to digest any new information.

45. Push the HDG SWITCH, on the console, to the "OFF" position.
46. Carefully adjust the ROLL COMMAND KNOB on the console to center the needle of the Power Section Test Box to ZERO. Remember to wait at least 30 seconds before taking any readings.
47. Push in the HDG SWITCH, on the console, to the "ON" position and also press in RED BUTTON on rear of radio coupler to observe the needle of the Power Section Test Box recenters on ZERO.
 - a. If needle does not recenter on ZERO, repeat Steps 41 thru 47 until centering is accomplished.
48. Push HDG SWITCH, on the console, to the "OFF" position.
49. Observe the physical position of the roll command knob on the console. Make sure the knob is straight up \pm approximately 3 degrees. If ROLL COMMAND KNOB is out of tolerance, replace console.
50. Press HDG SWITCH, on the console, to the "ON" position.
51. Place radio coupler SELECTOR SWITCH to the HEADING mode. Place the DIRECTIONAL GYRO SELECTOR CONTROL KNOB, located on the lower right hand corner of the Gyro Substitute Test Box, to the RIGHT HAND 45 degree position or full CLOCKWISE. Observe needle deflects RIGHT on the Power Section Box.
52. Rotate LARGE VERNIER KNOB on Gyro Substitute Test Box CLOCKWISE to the RIGHT HAND 20 degree position, reading the TOP SCALE labeled ROLL DEGREES.

NOTE

Large increments represent 5 degrees each.

53. With small slot head screwdriver, adjust the POTENTIOMETER inside the THIRD HOLE from the LEFT directly below the trim meter on the console to center the needle on the Power Section Test Box to zero. If unable to adjust to zero, replace console.
54. Observe NEEDLE OF OUTPUT METER, located on Radio Coupler Test Box, indicates RIGHT.
55. Leaving HEADING SWITCH "ON," rotate DIRECTIONAL GYRO SELECTOR CONTROL KNOB, located on lower right hand corner of the Gyro Substitute Test Box, to the LEFT HAND 45 degree position or full COUNTERCLOCKWISE. Observe needle deflects LEFT on Power Section Test Box.
56. Rotate LARGE VERNIER KNOB on Gyro Substitute Test Box COUNTERCLOCKWISE to the LEFT HAND 20 degree position, reading the TOP SCALE labeled ROLL DEGREES. With a small slot head screwdriver, adjust the POTENTIOMETER inside the LEFT HAND HOLE below the trim meter on the console to center the needle on the Power Section Test Box to zero. Wait a minimum of 30 seconds for the computer to digest the information.

57. Observe the **NEEDLE OF THE OUTPUT METER**, located on Radio Coupler Test Box, indicates **LEFT**.

58. Rotate the **DIRECTIONAL GYRO SELECTOR KNOB**, located at the lower right hand corner of the Gyro Substitute Test Box, to the **LEFT HAND 10 degree** position. Observe needle on Power Section Test Box moves to the **RIGHT**.

59. Observe the **NEEDLE** of the Output Meter on Coupler Test Box indicates **LEFT**.

60. Rotate the **LARGE VERNIER KNOB** on the Gyro Substitute Test Box **CLOCKWISE** to center the needle on Power Section Test Box, again waiting for computer to digest the new information.

61. Read the degree of bank on the Gyro Substitute Test Box from the **TOP SCALE** labeled **ROLL DEGREES**. The pointer must be between 8 and 13 degrees of bank angle.

NOTE

If out of tolerance, replace amplifier.

62. Rotate the **DIRECTIONAL GYRO SELECTOR KNOB**, located at the lower right hand corner of the Gyro Substitute Test Box, to the **RIGHT HAND 10 degree** position. Observe the needle of Power Section Test Box moves to the **RIGHT**.

63. Observe the **NEEDLE** of Output Meter on Coupler Test Box indicates **RIGHT**.

64. Rotate **LARGE VERNIER KNOB**, located on the Gyro Substitute Test Box **CLOCKWISE** to center the needle on the Power Section Test Box, again waiting for the computer to digest the new information.

65. Read the **DEGREE OF BANK** on the Gyro Substitute Test Box from the **TOP SCALE** labeled **ROLL DEGREES**. The pointer must be between 8 and 13 degrees of bank angle.

NOTE

If out of tolerance, replace amplifier.

66. Rotate **LARGE VERNIER KNOB**, located on Gyro Substitute Test Box, back to the **ZERO DEGREE** position on the **TOP SCALE** labeled **ROLL DEGREES**.

67. Rotate **DIRECTIONAL GYRO SELECTOR KNOB**, located on lower right hand corner of the Gyro Substitute Test Box, **COUNTERCLOCKWISE** to the **ZERO DEGREE** position.

68. Push the **HEADING SWITCH**, on the console, to the "OFF" position.

69. Rotate the **ROLL COMMAND KNOB** full right. Observe needle on Power Section Test Box indicates right.

70. Rotate the **LARGE VERNIER KNOB** on the Gyro Substitute Test Box **CLOCKWISE** to center the needle on Power Section Test Box, again waiting for the computer to digest the new information until the needle stays centered after at least a 30 second wait.

71. Read the degree of bank on the Gyro Substitute Test Box **TOP SCALE** labeled **ROLL DEGREES**. Bank must be 28 degrees \pm 3 degrees.

NOTE

If out of tolerance, replace console.

72. Rotate the **ROLL COMMAND KNOB** full **LEFT**.

73. Rotate **LARGE VERNIER KNOB** on Gyro Substitute Test Box **COUNTERCLOCKWISE** to center the needle on Power Section Test Box.

74. On the Gyro Substitute Test Box, read the degree of bank on the **TOP SCALE** labeled **ROLL DEGREES**. Bank must be 28 degrees \pm 3 degrees.

NOTE

If out of tolerance, replace console.

75. Recenter ROLL COMMAND KNOB to CENTER position. Recenter LARGE VERNIER KNOB on Gyro Substitute Test Box back to ZERO on TOP SCALE labeled ROLL DEGREES.
76. Push the HEADING SWITCH to the "ON" position.
77. Place the radio coupler SELECTOR SWITCH to the LOC/NORM mode and while holding IN the RED BUTTON on the rear of the coupler, observe needle on the Power Section Test Box points to zero \pm 2 divisions and the needle on the Output Meter on the Radio Coupler Test Box also reads zero \pm 2 small divisions.
78. Place the radio coupler SELECTOR SWITCH to the OMNI mode.
79. On the Radio Coupler Test Box, find RADIO SIGNAL SUBSTITUTE KNOB immediately to the right of the lower Omni Meter. Pull this KNOB to the OUT or "ON" position.
80. Rotate the RADIO SIGNAL KNOB to deflect lower OMNI METER to the RIGHT 100% POSITION. Observe needle of upper OUTPUT METER deflects RIGHT.
81. Rotate DIRECTIONAL GYRO SELECTOR KNOB on Gyro Substitute Test Box to the LEFT HAND 45 degree position full COUNTERCLOCKWISE.
82. WAIT 90 SECONDS. After waiting the required minimum 90 seconds of time, adjust the right INTERCEPT POTENTIOMETER SCREW located on the side of the radio coupler to center the needle of the Power Section Test Box to ZERO.
83. With OUTPUT METER of Power Section Test Box adjusted to ZERO, observe OUTPUT METER NEEDLE of Radio Coupler Test Box also indicates ZERO.

CAUTION

REMEMBER TO WAIT A MINIMUM OF 30 SECONDS AFTER MAKING ANY INTERCEPT ADJUSTMENTS.

84. Rotate RADIO SIGNAL KNOB on Radio Coupler Test Box to place the needle of the lower Omni Meter to the LEFT HAND 100% POSITION.
85. Rotate the DIRECTIONAL GYRO SELECTOR KNOB on Gyro Substitute Test Box CLOCKWISE to the RIGHT HAND 45 DEGREE POSITION. WAIT 90 SECONDS.
86. Adjust the LEFT INTERCEPT POTENTIOMETER SCREW, located on the side of the radio coupler, to center the needle of the Power Section Test Box to indicate ZERO.

CAUTION

REMEMBER TO WAIT AT LEAST 30 SECONDS BEFORE TAKING ANY READINGS AFTER MAKING INTERCEPT ADJUSTMENTS.

87. After needle of Power Section Test Box indicates ZERO, observe that upper OUTPUT METER of Radio Coupler Test Box indicates ZERO.
88. Refer to Paragraph 5-17 and set radio gain of coupler as outlined in Paragraph 5-17, Page 5-30 of this manual prior to completing the Roll Threshold Adjustment Procedure in the following paragraph.

5-9. ROLL THRESHOLD ADJUSTMENT FOR ALTIMATIC IIC.

Remove the base plate from the bottom of the amplifier to gain access to the roll threshold adjustment potentiometer. (Refer to Figure 5-2.)

CAUTION

Threshold adjustments are to be accomplished with a 12-volt calibrated bench set-up. When adjusting 28-volt systems, convert bench set-up to 12-volt configuration until Threshold Adjustment Procedure is completed. Verify all switches are returned to the 28-volt position prior to reinstallation in 28-volt aircraft. Setting of the large vernier control knob on the Gyro Substitute Test Box is critical when doing this adjustment procedure.

1. Disconnect the AMP connector CD-20 from the rear of the console and set the console aside.
2. Find CONSOLE SUBSTITUTE TEST BOX. Place the POWER SELECTOR SWITCH, located on the lower left hand corner of the Console Substitute Test Box, to the DOWN or "OFF" position.
3. Plug the AMP connector CD-20 into the receptacle, located on the top left corner of the Console Substitute Test Box.
4. Immediately to the right of the AMP connector CD-20 on the Console Substitute Test Box, find the (14 or 28-volt) SLIDE SWITCH. Place this switch in the 14-volt position.
5. Place the DIRECTIONAL GYRO slide switch, located on lower left of Console Substitute Test Box, in the UP or D.G. position.
6. Rotate SELECTOR KNOB, lower center of Power Section Test Box, CLOCKWISE to the "RES" position.
7. Ascertain the DIRECTIONAL GYRO SELECTOR KNOB, located on lower right hand corner of Gyro Substitute Test Box, is in the ZERO or straight "UP" position.
8. Rotate the LARGE VERNIER CONTROL KNOB on Gyro Substitute Test Box to the centered ZERO position reading the TOP SCALE labeled ROLL DEGREES.
9. Place the POWER SELECTOR SWITCH on lower left hand side of Console Substitute Test Box to the "ON" position. Observe SOLENOID LIGHT now glows on Power Section Test Box.
10. Rotate the ROLL TRIM KNOB on Console Substitute Test Box as required to center the needle on the Power Section Test Box to ZERO.
11. Rotate the LARGE VERNIER CONTROL KNOB on Gyro Substitute Test Box CLOCKWISE for a one (1) degree right bank.
12. Observe voltmeter on Power Section Test Box and record meter reading. (Refer to Figure 5-3 for enlarged view of voltmeter.)
13. Rotate the LARGE VERNIER CONTROL KNOB on Gyro Substitute Test Box, COUNTERCLOCKWISE for a one (1) degree left bank.
14. Observe voltmeter on Power Section Test Box and record meter reading. Average the meter readings obtained and refer to Table V-I for correct voltage settings.
15. If voltage setting is correct proceed to next step. If voltage setting is incorrect find the Roll Threshold Adjustment Potentiometer, located on the lower section of the amplifier printed circuit board (refer to Figure 5-2), and adjust to obtain an average of the voltage settings listed in Table V-I by repeating Steps 11 thru 14.
16. Rotate the Power Section Test Box Selector Knob COUNTERCLOCKWISE to the center or "OFF" position.
17. Place the POWER SELECTOR SWITCH on lower left hand side of Console Substitute Test Box to the "OFF" position.
18. Refer to the following paragraph for the Pitch Bench Set-up.

5-10. PITCH BENCH SET-UP FOR ALTIMATIC IIC.

1. Disconnect the AMP connector CD-20 from the Console Substitute Test Box and connect it to the console.
2. Unplug CD-47 connector attached to the face of the Power Section Test Box Amplifier receptacle. Set aside the CD-47 that was removed and in its place install the 4-pin male CD-16 connector.
3. Plug the 5-pin female CD-10 connector into the 5-pin male connector on right hand side of the Console Substitute Test Box.
4. Rotate the LARGE VERNIER CONTROL KNOB on the Gyro Substitute Test Box to read zero on the BOTTOM SCALE labeled PITCH DEGREES.
5. Immediately below the vernier control knob, find a SLIDE SWITCH labeled ROLL and PITCH. Place this switch in the "DOWN" or PITCH position.
6. Ascertain that the VOLTAGE SELECTOR SWITCHES of all the components are in the same position (14 or 28-volts DC) as the bench power supply. This will insure proper autopilot operation and prevent damage to the components.
7. Engage the ALTIMATIC IIC by pushing the ROLL ENGAGE SWITCH, on the console, to the "ON" position. DO NOT EXPECT SOLENOID LIGHT TO GLOW.
8. Push PITCH ENGAGE SWITCH, located on the console, to the "ON" position and observe solenoid light, located on the face of the Power Section Test Box, glows. If light glows, proceed with Step 15.
 - a. If solenoid light does not glow, recheck that CD-16 connector is installed in the receptacle on the face of the Power Section Test Box labeled Amplifier.
 - b. If solenoid light does not glow, recheck power supply voltage and wiring harness for correct connections.
 - c. If solenoid light still does not glow with cables properly connected and proper voltage applied, turn off power supply and proceed with next step.
9. Place the POWER SELECTOR SWITCH, located on the lower left hand corner of the Console Substitute Box to the DOWN or "OFF" position.
10. Remove the AMP connector CD-20 from the rear of the console and plug it into the CD-20 receptacle located on the top left corner of Console Substitute Test Box.
11. Immediately to the right of the AMP connector CD-20 find a 14 or 28-volt SLIDE SWITCH. Ascertain the switch is in the proper voltage position to agree with both the voltage selector switch on top plate of amplifier and the selector switch on the lower left corner of the Power Section Test Box.
12. Reapply voltage from power supply and place power selector switch on lower left hand side of Console Substitute Test Box to the UP or "ON" position. Observe solenoid light now glows on Power Section Test Box.

NOTE

If light DOES glow, replace autopilot CONSOLE. If light DOES NOT glow, replace autopilot AMPLIFIER.

13. Place the POWER SELECTOR SWITCH, located on the lower left hand corner of the Console Substitute Box to the DOWN or "OFF" position.
14. Unplug the AMP connector CD-20 attached to the Console Substitute Test Box and connect it to the CD-20 receptacle on the rear of the console.
15. Rotate the selector knob, located on the face of the Power Section Test Box, full CLOCKWISE to the "RES" position.
16. Make sure LARGE VERNIER CONTROL KNOB on Gyro Substitute Test Box is reading ZERO on the BOTTOM SCALE labeled PITCH DEGREES.
17. Rotate the PITCH COMMAND DISC up on AltiMatic Console, for a full DOWN command and observe needle of Power Section Test Box deflects LEFT.

18. Rotate the PITCH COMMAND DISC down for a full UP command and observe needle of Power Section Test Box deflects to the **RIGHT**.
19. Recenter PITCH COMMAND DISC so that the indice calls for a level attitude.
20. With small slot head screwdriver, adjust the **FIFTH POTENTIOMETER** from the left and located directly below the trim meter on the console to center the needle on the Power Section Test Box to **ZERO**. (Refer to Figure 5-1.)

NOTE

Keep in mind you **MUST WAIT 30 SECONDS** for the autopilot to digest any new information.

21. Rotate the **LARGE VERNIER CONTROL KNOB** on Gyro Substitute Test Box **COUNTERCLOCKWISE** to indicate 7 degrees nose down, reading **BOTTOM SCALE** labeled **PITCH DEGREES**.
22. Rotate PITCH COMMAND DISC UP for a full "DOWN" command.
23. With a small slot head screwdriver adjust the **FOURTH POTENTIOMETER** from the left, located directly below the trim meter on the console, to center the needle on the Power Section Test Box to **ZERO**. If unable to adjust to zero, replace console.
24. Rotate the **LARGE VERNIER CONTROL KNOB** on Gyro Substitute Test Box **CLOCKWISE** to indicate 10 degrees nose up reading **BOTTOM SCALE** labeled **PITCH DEGREES**.
25. Rotate PITCH COMMAND DISC down for a full "UP" command.
26. With a small slot head screwdriver adjust the **SIXTH POTENTIOMETER** from the left, located directly below the trim meter on the console, to center the needle on the Power Section Test Box to **ZERO**. If unable to adjust to zero, replace console.
27. Push the **ALT** engage switch, on the console, to the "**ON**" position.
28. Rotate the **LARGE VERNIER CONTROL KNOB** on Gyro Substitute Test Box **COUNTERCLOCKWISE** until the needle of the Power Section Test Box returns to **ZERO**.
29. Rotate PITCH COMMAND DISC down for a full "UP" command and then UP for a full "DOWN" command and note little change occurs on Power Section Test Box meter. Should a large amount of needle movement be present during pitch command disc movement recheck **ALT ENGAGE SWITCH**, located on the console, is in the **ON** position. (If a large amount of needle movement is still present during pitch command disc movement, replace console.) Recenter pitch command disc.
30. Push all console switches to the "**OFF**" position.
31. Refer to the following paragraph for Pitch Threshold Adjustment Procedure.

5-11. PITCH THRESHOLD ADJUSTMENT FOR ALTIMATIC IIIC.

Remove the cover plate from the top of the amplifier to gain access to the Pitch Threshold Adjustment Potentiometer. (Refer to Figure 5-2.)

CAUTION

Threshold adjustments are to be accomplished with a 12-volt calibrated bench set-up. When adjusting 28-volt systems, convert bench set-up to 12-volt configuration until Threshold Adjustment Procedure is completed. Verify all switches are returned to the 28-volt position prior to reinstallation in 28-volt aircraft. Setting of the large vernier control knob on the Gyro Substitute Test Box is critical when doing this adjustment procedure.

1. Disconnect the AMP connector CD-20 from the rear of the console and set the console aside.
2. Find CONSOLE SUBSTITUTE TEST BOX. Place the POWER SELECTOR SWITCH, located on the lower left hand corner of the Console Substitute Test Box, to the DOWN or "OFF" position.
3. Plug the AMP connector CD-20 into the receptacle, located on the top left corner of the Console Substitute Test Box.
4. Immediately to the right of the AMP connector CD-20 on the Console Substitute Test Box, find the (14 or 28-volt) SLIDE SWITCH. Place this switch in the 14-volt position.
5. Place the ALT CONTROL slide switch, located on lower left of Console Substitute Test box, in the UP or Alt Control position.
6. Place the ALTITUDE CONTROL KNOB, located on upper right of Console Substitute Test Box, to the straight up or 12 o'clock position.
7. Rotate the SELECTOR KNOB, lower center of Power Section Test Box, CLOCKWISE to the "RES" position.
8. Rotate the LARGE VERNIER CONTROL KNOB on Gyro Substitute Test Box to the ZERO position on the BOTTOM SCALE labeled PITCH DEGREES.
9. Immediately below the large vernier control knob on Gyro Substitute Test Box, find a SLIDE SWITCH labeled ROLL and PITCH. Place this switch in the "DOWN" or PITCH position.
10. Place the POWER SELECTOR SWITCH on lower left hand side of Console Substitute Test Box to the "ON" position. Observe SOLENOID LIGHT now glows on Power Section Test Box.
11. Rotate the PITCH TRIM KNOB on Console Substitute Test Box as required to center the needle on Power Section Test Box to ZERO.
12. Rotate LARGE VERNIER CONTROL KNOB on Gyro Substitute Test Box COUNTERCLOCKWISE to indicate three-quarters (3/4) degree nose down, reading BOTTOM SCALE labeled PITCH DEGREES.
13. Observe voltmeter on Power Section Test Box and record meter reading. (Refer to Figure 5-3 for enlarged view of voltmeter.)
14. Rotate the LARGE VERNIER CONTROL KNOB on Console Substitute Test Box CLOCKWISE to indicate three-quarters (3/4) degree nose up, reading BOTTOM SCALE labeled PITCH DEGREES.
15. Observe voltmeter on Power Section Test Box and record meter reading. Average the meter readings obtained and refer to Table V-II for correct voltage settings.
16. If voltage setting is correct proceed to next step. If voltage setting is incorrect find the Pitch Threshold Adjustment Potentiometer, located on upper section of amplifier printed circuit board, (refer to Figure 5-2) and adjust to obtain an average of the voltage setting listed in Table V-II by repeating Steps 12 thru 15.
17. Place the POWER SELECTOR SWITCH on Console Substitute Test Box to the "OFF" position.
18. Disconnect test equipment and associated cables and reinstall the components in the airplane.
19. Proceed with ground checks and flight adjustments.

5-12. ALTIMATIC IIC GROUND CHECKS WITH RADIO COUPLER (ROLL).

1. Remove the console face plate by removing the roll command knob and four face plate mounting screws. After removing the face plate, reinstall the roll command knob to facilitate accomplishing in-flight adjustments.
2. Center the roll command knob and position HDG and ROLL engage switches to the "OFF" position.
3. Start airplane engine to obtain gyro stability.

4. Place the airplane control wheel to approximately neutral aileron or level flight position. Push ROLL engage switch to the "ON" position. Move control wheel right and left to check for servo engagement.

5. Rotate the Roll Command Knob to the right and to the left and observe that the airplane control wheel moves in the correct direction. (The airplane control wheel can be stopped in any position and will not return to level position by centering the roll command knob. The airplane wheel will remain stationary at the time the roll command knob is approximately centered or at its zero electrical output position.)

6. Center the heading bug of the directional gyro or horizontal situation indicator and push console HDG SWITCH "ON." WITH THE CONSOLE HDG SWITCH PUSHED TO THE "ON" POSITION, THE ROLL COMMAND KNOB ON THE CONSOLE BECOMES INOPERATIVE.

7. Set the heading bug for a heading change to the right, observe control wheel should turn right. Make same check to the left. Return the heading bug to existing aircraft heading.

8. Turn on number one (1) NAV receiver and tune in a local OMNI station.

9. Observe warning flag on face of OMNI converter or HSI retracts from view. (If flag does not fully retract, this indicates an unusable OMNI signal is present.) Before proceeding, a usable OMNI signal must be present or utilize an approved OMNI simulator.

10. Rotate the OBS knob (or the CRS knob of the HSI) to center the CDI needle and provide an on course signal with a "TO" indication.

NOTE

On installations incorporating the DG-360 the A/P Radio Course Arrow is placed on the heading corresponding to the radial selected by the OBS.

11. Place radio coupler in omni mode. Rotate OBS knob (or the CRS knob of the HSI) to cause the course deviation indicator to move to the right and to the left and observe that the control wheel moves to the same side as the Course Deviation Needle.

12. Repeat Steps 8 thru 11 with number two (2) NAV receiver on systems incorporating the standard DG or the DG-360.

13. Push ROLL ENGAGE SWITCH to the "OFF" position. Rotate the control wheel right and left and observe that the servo disengaged.

5-13. GROUND CHECK - PITCH.

1. Plug the CD-18 lead from attitude horizon into the CD-18 plug of the Gyro Substitute Test Box.

2. Place the roll pitch selector switch on Gyro Substitute Test Box to the PITCH position.

3. Rotate the large vernier control knob on Gyro Substitute Test Box to read ZERO on BOTTOM SCALE labeled PITCH DEGREES.

4. Pull AUTOMATIC PITCH TRIM CIRCUIT BREAKER and/or place panel mounted trim switch to the OUT position.

5. Turn ON airplane Master Switch.

6. Push roll engage switch "ON" and stop control wheel rotation by adjusting ROLL COMMAND KNOB.

7. Center trim meter on console by rotating pitch command disc.

8. Push pitch engage switch ON. Move control column fore and aft and note that pitch servo engaged. Listen for audible sound.

9. Rotate PITCH COMMAND full up and observe control column moves aft.

10. Rotate PITCH COMMAND DISC full down and observe control column moves forward.

NOTE

On the PA-31 series airplane, when checking the pitch portion of the autopilot on the ground, due to the weight of the elevator and the down spring in the elevator control system, with the pitch servo engaged, the pitch servo clutch will slip instead of moving the elevator.

11. Rotate PITCH COMMAND DISC to center position.
12. Push pitch engage switch OFF. Move control column fore and aft and note that pitch servo disengaged.
13. Push TRIM CIRCUIT BREAKER and/or the panel mounted trim switch to the IN or ON position.
14. Push the roll engage switch and the pitch engage switch ON.
15. Rotate pitch command disc for full NOSE UP command and hold control wheel from moving aft. Pitch trim should trim nose UP after a slight delay and trim meter should deflect up.
16. Rotate pitch command disc for full NOSE DOWN command and hold control wheel from moving forward. Pitch trim should trim nose DOWN after a slight delay and trim meter should deflect down.
17. Recenter pitch command disc.
18. Depress the disengage button incorporated in the trim switch and move the trim switch forward. Autopilot should disengage and pitch trim should trim nose DOWN.
19. With the disengage button depressed move the switch aft. Pitch trim should trim nose UP.
20. The trim switch should be inoperative in both directions if the disengage button is not depressed.
21. Disconnect the CD-18 lead from the Gyro Substitute Test Box and connect it to the artificial horizon.

NOTE

PA-31 series airplanes ONLY. In the event it cannot be determined by an audible sound that the pitch servo motor is running in response to pitch signals from the pitch command disc, it will be necessary to remove the center floor panel. When removing panel on PA-31P airplanes, handle panel carefully to avoid damaging panel sealing gasket. Ascertain panel sealing gasket is clean and undamaged prior to installation to prevent cabin pressure leaks. Connect the CD-16 connector to the amplifier connector on the Power Section Test Box and the CD-16 extension to the servo and the servo connector also on the Power Section Test Box. Place the selector switch on the Power Section Test Box to the MTR position. Check for pitch amplifier output on the meter of the Power Section Test Box and verify the servo motor is operating when performing Steps 8 thru 12.

5-14. ALTIMATIC IIC FLIGHT ADJUSTMENTS WITH RADIO COUPLER (ROLL).

1. The aircraft shall be loaded to or near its AFT-C.G. LIMIT for flight set-up to assure all flight profiles are met. Consult AIRCRAFT WEIGHT AND BALANCE DATA TO ENSURE FUEL BURN DURING FLIGHT SET-UP DOES NOT PLACE AIRCRAFT OUTSIDE THE C.G. ENVELOPE. Previous Altimatic series Autopilots do not require this loading. (Refer to Flight Manual for proper power settings.)

NOTE

For adjusting descent, 19 inches of mercury manifold pressure must be used on all airplanes except the PA-31-310, PA-31-325 and PA-31-350 which must be adjusted at 20 inches of mercury and the PA-31P which must be adjusted at 25 inches of mercury.

2. MAKE CERTAIN RUDDER TRIM IS ADJUSTED TO CENTER THE BALL. IF RUDDER IS INCORRECTLY TRIMMED, THE ALTIMATIC WILL FLY THE AIRPLANE WITH A WING LOW TO COMPENSATE FOR OUT OF TRIM RUDDER.

NOTE

SMOOTH AIR IS REQUIRED.

3. Set the coupler selector switch in the OMNI mode.
4. Set the heading bug to the aircraft heading.
5. Push roll engage switch "ON." Depress RED BUTTON on rear of coupler and push HDG engage switch ON. Keep coupler switch depressed during next adjustment.
6. Allow airplane roll attitude to stabilize and if necessary, adjust for straight and level flight (wings level and ball centered). To do this, adjust the potentiometer located inside the SECOND HOLE from the left. After each adjustment, allow the airplane attitude to stabilize and observe it for two minutes to insure airplane is maintaining level flight. Release coupler adjustment switch.
7. Place COUPLER SELECTOR SWITCH in the HEADING mode and observe that airplane maintains selected heading ± 2 degrees.
8. Rotate HEADING BUG 150 degrees left and observe airplane bank angle. Adjust left bank screw of console to obtain 20 degree bank. Rotate ADJUSTMENT SCREW clockwise to increase bank angle.

NOTE

Keep heading bug at least 25 degrees left of directional gyro HEADING until adjustment is complete.

9. Rotate HEADING BUG 150 degrees right and observe airplane bank angle. Adjust right bank screw of console to obtain 20 degree bank. Rotate ADJUSTMENT SCREW clockwise to increase bank angle.

NOTE

Keep heading bug at least 25 degrees right of directional gyro HEADING until adjustment is complete.

10. Turn on radio and rotate the OBS knob (or the CRS knob of the HSI) to deflect CDI needle full left.

NOTE

Full left needle deflection must be maintained until adjustment is complete. This can be accomplished by being at least 20 miles from the Omni station and flying approximately to or from the station.

11. Push HDG SWITCH "OFF" and set HEADING BUG 45 degrees right of center index. Place COUPLER in OMNI mode.
12. Push HDG SWITCH "ON" and allow the airplane heading to stabilize for 90 seconds.
13. Adjust LEFT INTERCEPT SCREW on side of radio coupler as necessary to stabilize heading bug 45 degrees right of center index. Turn adjustment screw CLOCKWISE to increase intercept angle. Allow 90 seconds for HEADING to stabilize after each adjustment.

THIS PAGE INTENTIONALLY LEFT BLANK

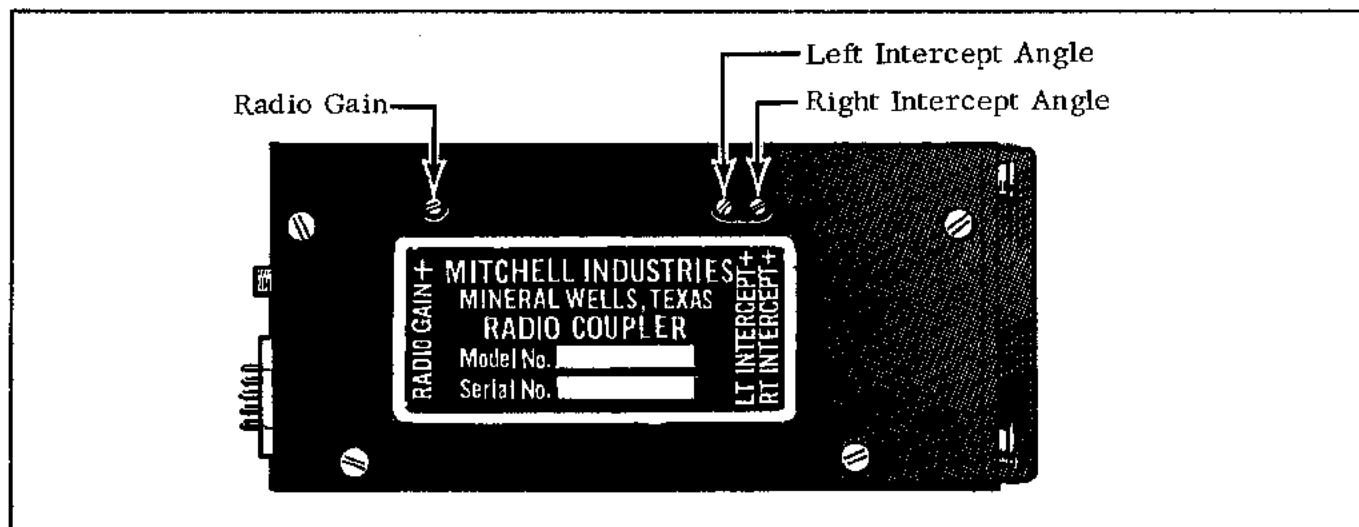

Figure 5-6. Radio Coupler Adjustment Points

14. To adjust right intercept angle, repeat Steps 10 thru 13 with omni needle deflected full right and heading bug 45 degrees to left of center index.

15. Center CDI needle on a "TO" bearing and set heading bug to match omni bearing. Allow airplane to fly to the omni station and observe that CDI needle stays CENTERED. If CDI needle does not maintain center, adjust ROLL centering toward CDI needle. Repeat Steps 7, 8 and 9.

5-15. ALTIMATIC IIC FLIGHT ADJUSTMENT - PITCH.

1. The aircraft shall be loaded to or near it's AFT-C.G. LIMIT for flight set-up to assure all flight profiles are met. Consult AIRCRAFT WEIGHT AND BALANCE DATA TO ENSURE FUEL BURN DURING FLIGHT SET-UP DOES NOT PLACE AIRCRAFT OUTSIDE THE C.G. ENVELOPE. Previous Altimatic series Autopilots do not require this loading. (Refer to Flight Manual for proper power settings.)

NOTE

SMOOTH AIR IS REQUIRED.

2. For adjusting descent, 19 inches of mercury manifold pressure must be used on all airplanes except the PA-31-310, PA-31-325 and PA-31-350 which must be adjusted at 20 inches of mercury and the PA-31P which must be adjusted at 25 inches of mercury.

3. Push roll engage switch ON, adjust roll command knob as required for wings level flight.

4. Rotate pitch command disc as required to center trim meter.

5. Observe existing altitude and push ALT engage switch ON. Allow aircraft to stabilize and observe that aircraft is holding the same altitude at which the ALT hold function was engaged. If aircraft does not hold engage altitude, adjust the FIFTH POTENTIOMETER from the left, on the console, as required to maintain existing altitude.

NOTE

Turning potentiometer clockwise will increase altitude.

6. Push pitch engage switch OFF. Observe existing altitude and push ALT engage switch ON and allow aircraft to stabilize and observe that aircraft is holding the same altitude at which the ALT hold function was engaged. Repeat Steps 5 and 6 until correct results are obtained.

7. Center the pitch command disc and push ALT engage switch OFF.
8. Rotate pitch command disc, if necessary, to maintain level flight. After aircraft is stabilized in level flight, observe that pitch command disc is centered $\pm 1/8''$.
9. Reduce the power setting per appropriate airplane Flight Manual and rotate the Pitch Command Disc UP for a full DOWN command. After the aircraft has stabilized in descent, adjust the FOURTH POTENTIOMETER from the left, on the console, for a 7 degree descent. (5 degrees on PA-32 and PA-34-200T.)

CAUTION

It may be necessary to reduce power to prevent excessive speed.

10. Advance the power setting per appropriate airplane Flight Manual and rotate pitch command disc DOWN for a full UP command. After the aircraft has stabilized in climb, adjust the SIXTH POTENTIOMETER from the left, on the console, for a 10 degree climb. (7 degrees on PA-32 and PA-34-200T.)
11. Recenter the pitch command disc.
12. This completes the Flight Set-up.

5-16. ALTIMATIC IIC GROUND CHECK (OPTIONAL YAW DAMPER).

1. Level the aircraft laterally using a level or bubble protractor. Refer to appropriate Airframe Service Manual for leveling instructions.
2. Gain access to yaw damper amplifier and loosen locknut on adjustment potentiometer.
3. Turn ON airplane Master Switch.
4. Push panel mounted yaw damper engage switch ON.
5. Observe system for rudder pedal movement or slowly running rudder servo.
6. Adjust centering potentiometer as required to stop rudder servo movement.
7. Recycle the system two or three times to insure servo movement is completely cancelled.
8. After adjustment is complete secure locknut on potentiometer.

NOTE

Any movement of the aircraft, or moving around in the aircraft with the yaw system engaged, can cause the rate gyro in the yaw damper to send a corrective signal to the servo. This signal will cause the servo to run unintentionally, so during the adjustment procedure all movement should be kept to a minimum.

9. With the yaw damper system engaged, go to the rear of the aircraft and move the tail of the aircraft, laterally back and forth. Observe rudder action. The yaw damper should attempt to move the rudder opposite to the yaw direction.

5-17. CHECK AND ADJUSTING RADIO GAIN.

Although the radio gain on all couplers from the factory is preset, the following procedures are for bench adjustment of the radio coupler gain. For omni converters with standard ARINC meter outputs, it will be necessary to set up the autopilot on the bench as per paragraph 5-8 for the AltiMatic IIC. After the equipment is connected and functioning, perform the following adjustments and steps.

NOTE

The Piper Omni/Localizer Coupler presents a high impedance load (greater than 10K ohms) to the radio installation. Therefore, it will not "load down" the omni converter.

- a. Adjusting Coupler Gain for Standard ARINC.
 1. VERY SLOWLY rotate the RADIO SIGNAL SUBSTITUTE KNOB in the direction required to cause the omni meter needle to move slowly back toward center.
 2. While omni meter needle is traveling slowly toward center, observe upper output meter (directly above omni meter on Coupler Test Box) and note the moment the upper output meter begins to respond.
 3. The instant the upper output meter needle shows response, stop rotation of the RADIO SIGNAL SUBSTITUTE KNOB.
 4. Read the lower omni needle and determine what percentage on the dial was reached when upper output meter needle shows response.

NOTE

At 100% (\pm one meter division) the upper output meter should just begin to move. Adjust the radio gain screw on the coupler until the above indication can be obtained.

5. If radio gain has been adjusted, recheck both intercept angles and adjust if necessary.
6. Upon completion of radio gain adjustment, refer to Paragraph 5-9, page 5-21 of this manual for Roll Threshold Adjustment Procedure.
- b. Adjusting Coupler Gain for unknown Omni Converter: It is necessary to determine the output signal capabilities of the unknown omni converter as compared to a standard ARINC signal.
 1. Remove the airplane cable CD-34 connector from the rear of the radio coupler in the airplane.
 2. Plug this airplane cable CD-34 plug into the CD-34 connector located on the top right corner of Radio Coupler Test Box labeled "RADIO."

NOTE

The CD-34 extension cable can be used to make this connection.

3. Make sure RADIO SIGNAL SUBSTITUTE KNOB on Coupler Test Box is in the "IN" position.
4. Turn on Master Switch.
5. Turn on VOR Radio.
6. Tune in a local OMNI station.

CAUTION

Make sure you are receiving a strong usable OMNI signal before taking any readings. It is good practice to use an OMNI signal generator.

7. Center CDI on OMNI set with OBS by rotating OBS with a "TO" reading.

8. Note OMNI meter needle on Radio Coupler Test Box is centered.
9. Rotate the OBS of the radio enough to drive CDI just to the end of its travel (off scale) to a full deflection.
10. Read the OMNI meter needle on the Coupler Test Box and note the reading in percent.
11. Turn off airplane Master Switch and remove Coupler Test Box from airplane.
12. Proceed with the following steps if the roll set-up has been completed. If the roll has not been set up, complete set-up at this time.
13. After completing roll set-up, pull OUT the RADIO SIGNAL SUBSTITUTE KNOB on the Coupler Test Box.
14. Place the switch on the radio coupler to the LOCALIZER/NORM position.
15. Place roll switch "ON."
16. Place heading switch "OFF."
17. Place DG to "ZERO."
18. Rotate the RADIO SIGNAL SUBSTITUTE KNOB right or left until OMNI meter needle indicates the same percentage figure as read in the airplane.
19. Wait three minutes to insure Coupler Memory Bank is filled.
20. VERY SLOWLY rotate the RADIO SIGNAL SUBSTITUTE KNOB in the direction required to cause the OMNI meter needle to move slowly back towards center.
21. While OMNI meter needle is traveling slowly towards center, observe upper output meter and note the moment the upper output meter needle begins to respond.
22. The instant the upper output meter needle shows response, stop rotation of the radio signal substitute knob.
23. Read the lower OMNI meter needle and determine what percentage on the dial was reached when upper output meter needle shows response.

NOTE

Adjust radio gain on coupler so that upper output meter needle responds within ± 1 lower meter division of the percentage as originally read on airplane radio.

24. If coupler gain has been adjusted, recheck both intercept angles and adjust if necessary.

5-18. PIPER OMNI/LOCALIZER COUPLER MODIFICATION (1C388 SERIES).

The Piper Omni/Localizer Coupler is used in conjunction with various configurations of avionics equipment. Depending on the type avionics equipment installed in the airplane, the coupler should be modified as follows:

- a. When the coupler is used in conjunction with the VOA-4, -5, -8 or -9 and/or other converters where $20^\circ = 150$ microamps, modify as follows:
 1. Identify the 1C388 coupler as "F" mod or higher (letter F at end of serial nos.).
 2. Remove eight screws and cover of radio coupler.
 3. Locate clipped jumper across 10K resistor. (Refer to Figure 5-7.)
 4. Using small soldering iron, carefully re-solder jumper. (Exercise extreme caution to prevent inadvertent damage with soldering iron.)
 5. Replace cover and secure with eight screws.
- b. When the coupler is used in conjunction with VOA-40 or VOA-50 and/or other converters where $10^\circ = 150$ millivolts, the jumper is clipped so the 10K resistor is in the circuit.

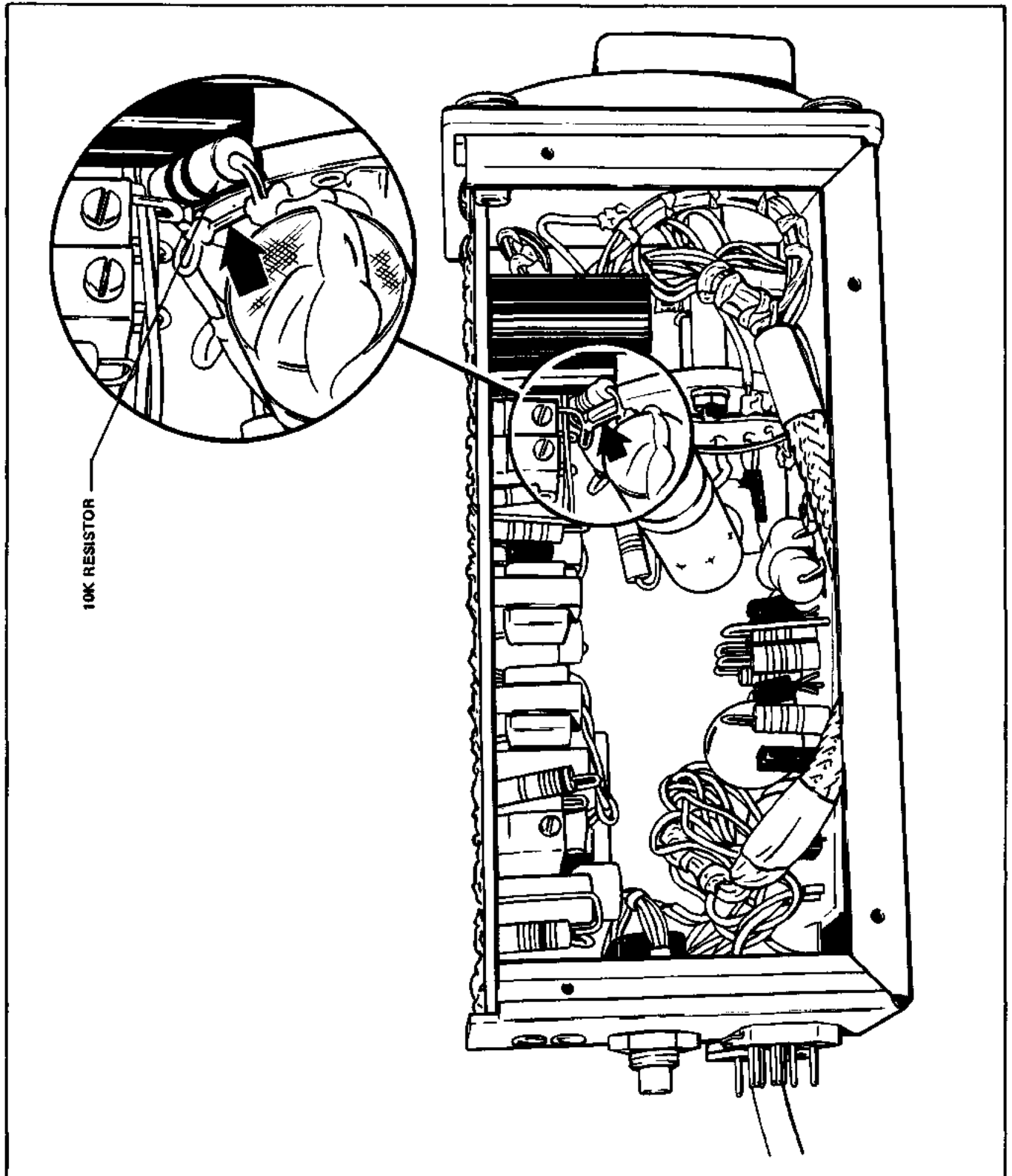

Figure 5-7. Piper Omni/Localizer Coupler Modification Detail

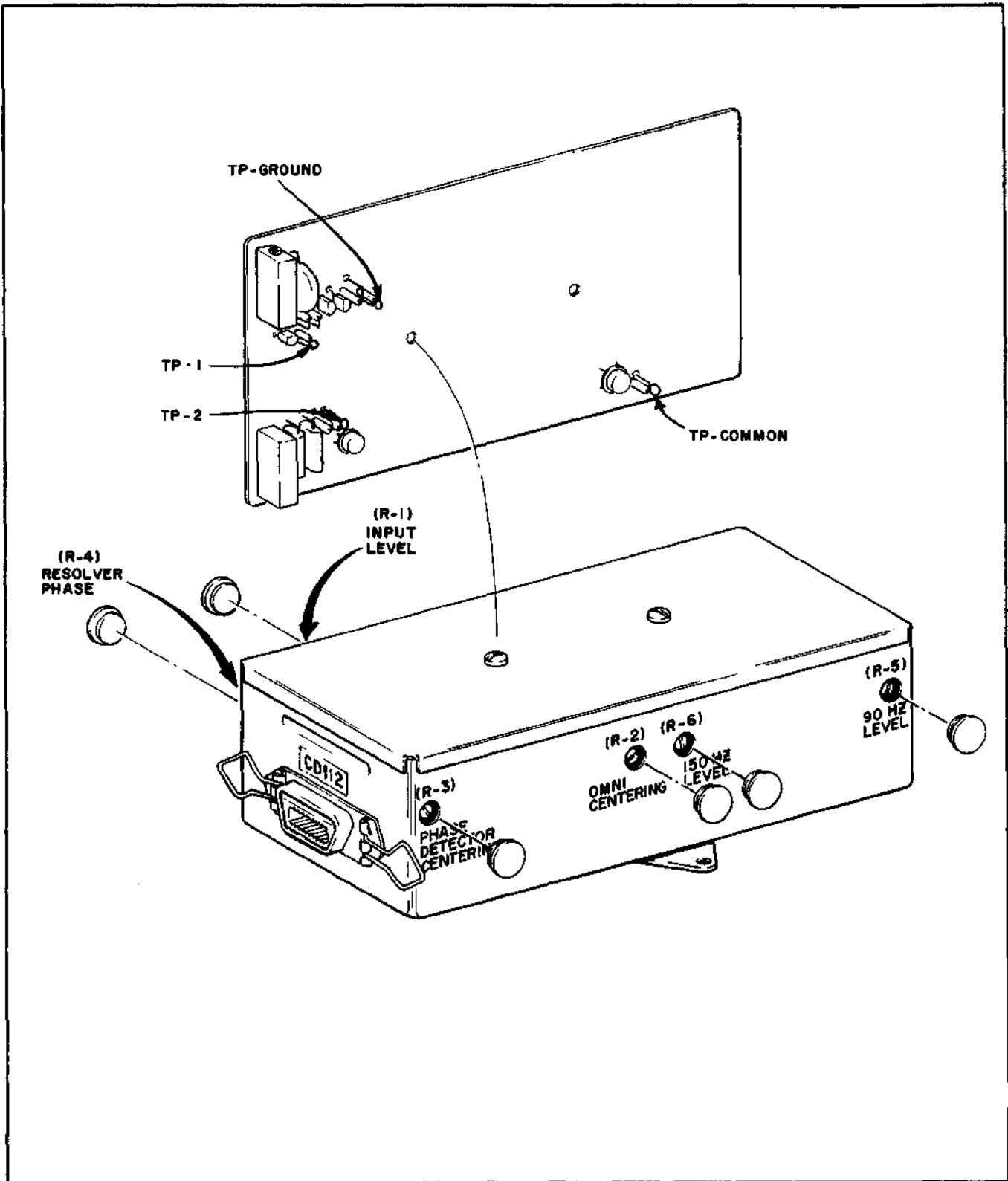

Figure 5-8. NAV Converter (IC707) Adjustment Potentiometers

5-19. NAV CONVERTER (1C707) ALIGNMENT PROCEDURE.

The Navigation Converter (1C707) is designed to accept any VHF radio receiver omni composite signal between .3 VRMS and 3.0 VRMS signal level and any standard ARINC resolver signal level as specified by ARINC Report No. 407-1 for OBS resolvers. The 1C707 can provide sufficient output, isolated from ground but not necessarily from the deviation output circuit, to drive a total of 4 flag alarm movements of 1000 OHMS, 250ua from the VOR/LOC function. The flag alarm output requires no adjustment when adding one to four loads. The deviation indicator output circuits will provide a suitable signal, isolated from ground, to drive 5 localizer 1000 OHM 150-0-150 micro ampere deviation indicator movements in parallel with suitable service adjustments to set proper course sensitivity independently on localizer and VOR functions, to the particular standardized course width. The TO/FROM circuits of the 1C707 is capable of delivering 200 micro amperes (+ 20%) to each of two paralleled TO/FROM indicators, each of 200 OHMS ± 15%. No adjustment is required to vary TO/FROM loads.

CAUTION

The EDO-AIRE 1C707 VOR/LOC Converter Maintenance Manual AK423 should be utilized in conjunction with the Alignment Procedure outlined in the following paragraphs.

- a. 1C707 OMNI/LOCALIZER CONVERTER SET UP PROCEDURE. (Refer to Figure 5-8.)

NOTE

Required Test Equipment - TIC-12A VOR Simulator Generator or, IFR-401L VOR Simulator Generator or Equivalent.

1. Connect 1C707 Omni Converter to Navigation Receiver and Deviation Indicator.
2. Supply 28/14 VDC to Pin 13 (standard A/C power).
3. With converter connected and all equipment set up for standard VOR operation, apply a standard VOR test signal from a TIC-T-12A Omni Simulator (or equivalent) to the antenna terminals of the navigation receiver. (Use simulator operating procedure to accomplish task.)
4. Verify that all equipment is operating before proceeding. (See Note)

CAUTION

Test Point Common is approximately 6 volts above ground. Do not inadvertently ground the test point with scope or meter ground lead.

NOTE

When using VOM, set level at 1.41 VRMS between TP-1 or TP-2 and Test Point Common.

When using scope set level at 4 VP-P. From TP-ground use either AC coupling or D.C. coupling. TP-1 and TP-2 have approximately 6 V.D.C. component.

5. With a standard VOR signal applied adjust R-1 VOR receiver (input level) for 4.0 VP-P or 1.41 VRMS at Test Point 1. See Figure 5-8. (See Note)

6. Check for 4 VP-P or 1.41 VRMS \pm 15% at Test Point 2. See Figure 5-8. (See Note)
7. Set generator to 0° "TO" and resolver to 0°. Adjust R + 2 (Omni Centering) for zero on deviation indicator. Access to omni centering adjustment on side of the converter.
8. Set generator to 0° "FROM." Adjust R-3 (Phase Detector Bal) to correct for 50% of the error on deviation indicator. Access to phase detector adjustment on side of the converter.
9. Repeat Steps 7 and 8 until the generator can be changed from 0° TO, to 0° FROM with no error indicated on deviation indicator.
10. Set generator to 90°. Set resolver to 90°. Adjust R-4 (Resolver 0) to reduce deviation indicator reading approximately 80%. Access to resolver adjustment on side of the converter.
11. Repeat Steps 7 and 10 until no error is indicated in either step.
12. Recheck Step 5.
13. Set generator to 0° "TO." Set resolver until deviation indicator just reaches full scale deflection. The resolver should read 11° \pm 1° (minor adjustment of input level control may be made to accomplish above but reading in Step 5 should not vary more than \pm 20%).
14. Vary resolver from 80° to 280°. "TO - FROM" should indicate "TO."
 - a. Vary resolver from 100° to 260° "TO - FROM" should indicate "FROM." (The above may also be accomplished by setting the resolver to 0° and varying the generator to the same bearings indicated.) Check VOR error. Limit 1° at any point.
15. Delete 9960 Hz. Check for NAV flag in full view.
 - a. Delete 30 Hz. Check for NAV flag in full view.
16. Set NAV receiver to localizer frequency.
17. Set up simulator for standard localizer signal as defined by simulator operating manual.
18. With modulation depth control set to 0 db adjust R-5 (90 Hz level) or R-6 (150 Hz level) for zero deflection on the deviation indicator. Access to the 90 Hz and 150 Hz adjustment can be found on the side of the converter box.
 19. Set modulation depth control to + 4 db. Deviation indicator should deflect 60%.
 20. If deflection exceeds 60%, set modulation depth control to zero db and simultaneously decrease R-5 (90 Hz level) and R-6 (150 Hz level) 2 or 3 turns to maintain zero deviation on indicator. (If less than 60% increase 90 and 150 Hz.)
 21. Repeat Steps 19 and 20 until 4 db modulation depth gives 60% deflection.
 22. -4 DB modulation depth should give 60% right deflection. Set modulation depth to zero.
 23. "TO - FROM" should indicate "TO."
 24. Delete 90 Hz; NAV Flag should be in full view, "TO - FROM" should be out of view and full left deflection.
 25. Delete 150 Hz. Indications same as Step 24, except with full right deflection.
 26. Set modulation depth control to +4 db. "TO - FROM" should start to indicate "TO."
 27. Decrease the simulator signal level until 4 db modulation depth gives 30% deflection. NAV Flag should be in partial view.

NOTE

When OBS is 180° out of phase with the deviation test signal reverse pins 20 and 2 on converter connector CD-112.

5-20. ADJUSTMENTS OF SLAVING SUB-SYSTEM.

The following adjustments of the slaving sub-system must be made any time a component is replaced in the system or if large heading errors exist in the system. A compass rose must be available to accurately determine the actual airplane heading or a Master Sighting Compass may be used. Make duplicates of the sample charts in Figure 5-9 to record pertinent information required during the following adjustment procedures.

CAUTION

All Flux Sensor mounting hardware and other hardware within one to two feet of the Flux Sensor must be of non-magnetic material to reduce the stray magnetic fields in the area of the Flux Sensor.

NOTE

The serviceman must gain access to the Flux Sensor and North-South/East-West Corrector as outlined in Section III of this manual, Removal and Installation, for the type of airplane being serviced.

1. Taxi the airplane to the compass rose and align the airplane on 0 degrees heading, utilizing the compass rose or a Master Sighting Compass to arrive at the heading.
2. Record the actual magnetic heading on the deviation chart.
3. Record the Horizontal Situation Indicator azimuth card reading on the deviation chart.
4. Determine and record the deviation between the actual magnetic reading and the azimuth card reading. If the azimuth card reads high, the deviation is plus.
5. Taxi the airplane for an East Heading, utilizing the compass rose or a Master Sighting Compass to arrive at the heading.
6. Record the actual magnetic heading on the deviation chart.
7. Record the Horizontal Situation Indicator azimuth card reading on the deviation chart.
8. Determine and record the deviation between the actual magnetic reading and the azimuth card reading. If the azimuth card reads high, the deviation is plus.
9. Taxi the airplane for a South Heading, utilizing the compass rose or a Master Sighting Compass to arrive at the heading.
10. Record the actual magnetic heading on the deviation chart.
11. Record the Horizontal Situation Indicator azimuth card reading on the deviation chart.
12. Determine and record the deviation between the actual magnetic reading and the azimuth card reading. If the azimuth card reads high, the deviation is plus.
13. Taxi the airplane for a West Heading, utilizing the compass rose or a Master Sighting Compass to arrive at the heading.
14. Record the actual magnetic heading on the deviation chart.
15. Record the Horizontal Situation Indicator azimuth card reading on the deviation chart.
16. Determine and record the deviation between the actual magnetic reading and the azimuth card reading. If the azimuth card reads high, the deviation is plus.
17. Plot the deviations on the initial deviation graph.
18. If the deviation pattern is not centered around zero, rotate the Flux Sensor clockwise for minus deviations or counterclockwise for plus deviations. Plot final deviations on the Final Deviation Graph.

19. Taxi the airplane for a 0 degree heading, utilizing the compass rose or a Master Sighting Compass to arrive at the heading.

20. Adjust the North-South Corrector Adjustment (refer to Figure 5-10) by rotating the potentiometer (clockwise for minus or counterclockwise for plus deviations) in the correct direction for one half the difference between North and South deviations. Record the new deviation for North and South on the Final Deviation Graph.

21. Taxi the airplane for an East Heading, utilizing the compass rose or a Master Sighting Compass to arrive at the heading.

22. Adjust the East-West Corrector Adjustment (refer to Figure 5-10) by rotating the potentiometer (clockwise for minus or counterclockwise for plus deviations) in the correct direction for one half the difference between East and West deviations. Record the new deviation for East and West on the Final Deviation Graph.

23. Taxi the airplane for a South Heading, utilizing the compass rose or a Master Sighting Compass to arrive at the heading. Record new deviation on Final Deviation Graph.

24. Taxi the airplane for a West Heading, utilizing the compass rose or a Master Sighting Compass to arrive at the heading. Record new deviation on Final Deviation Graph.

25. The deviations should now center around the zero reference line of the Final Deviation Graph. If the error exceeds ± 2 degrees, the complete procedure must be reaccomplished.

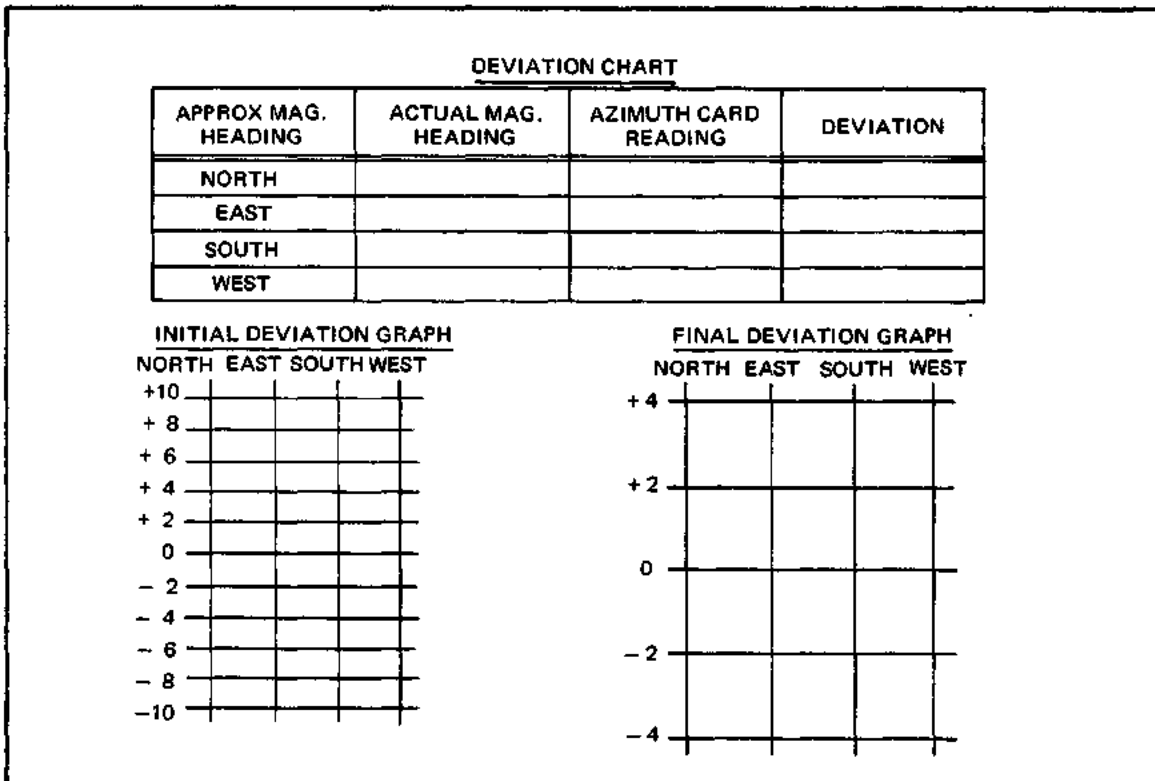

Figure 5-9. Sample Deviation Charts

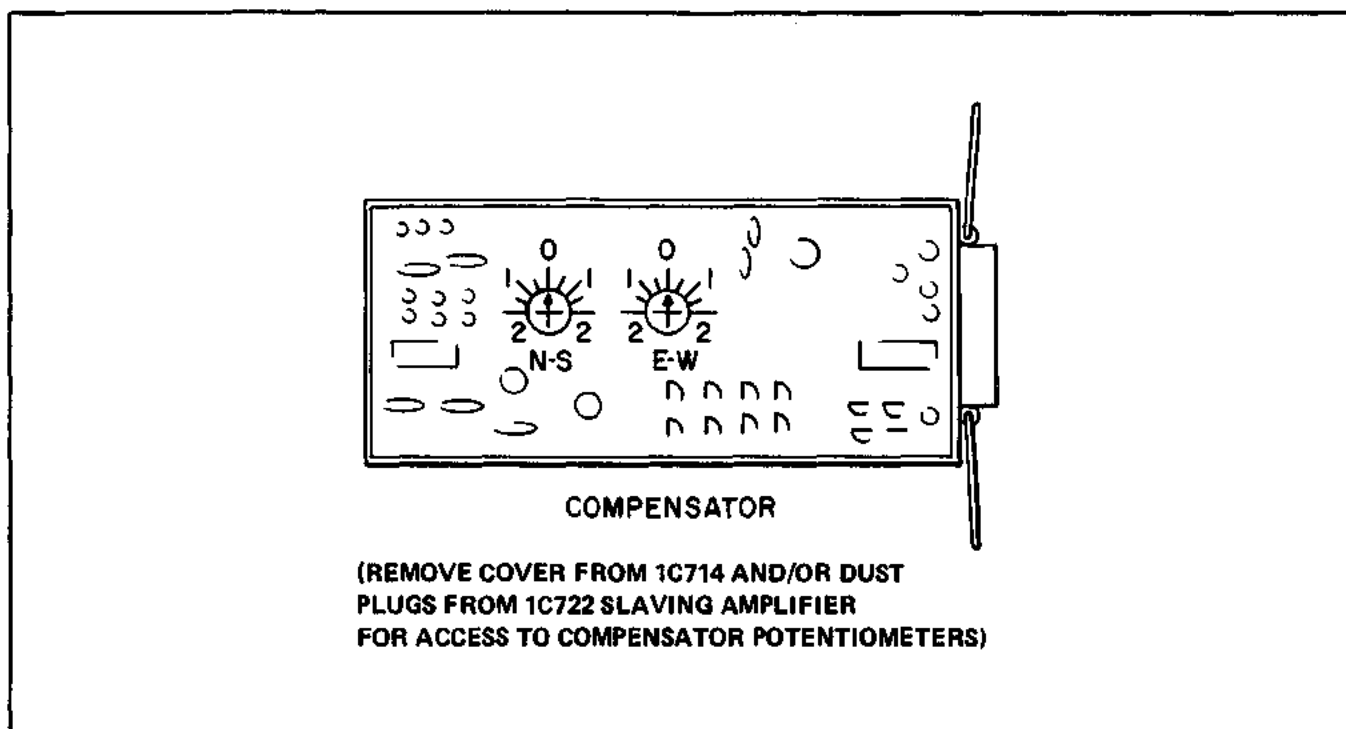

Figure 5-10. Slaving Amplifier, N-S/E-W Corrector Adjustment Potentiometers

5-21. ALTIMATIC IIC WITH OPTIONAL KING KCS-55 COMPASS SYSTEM ALIGNMENT PROCEDURE.

The AltiMatic IIC may incorporate the optional KCS-55 compass system in lieu of the EDO-AIRE Mitchell compass system. The KCS-55 compass system utilizes a KA-52 autopilot adapter which requires special adjustment to obtain correct bank and intercept angles. The following paragraphs provide the information to accomplish the required adjustment procedures.

The 1C388-3 Radio Coupler is utilized with this system as it will couple any ARINC compass system to the autopilot. Should the KA-52 autopilot adapter require replacement this procedure must be accomplished. If the KA-52 is not adjusted properly, on existing systems, the bank and intercept angles will be something less than the recommended setting. Therefore, this procedure should be utilized prior to setting the bank and intercept angles of the autopilot.

- a. KA-52 AUTOPILOT ADAPTER ALIGNMENT PROCEDURE. (Refer to Figure 5-12.)

NOTE

Required Test Equipment - Precision Voltmeter and a locally fabricated In-Line Test Box as shown in Figure 5-11.

1. Disconnect the compass system harness connector CD-33 from the radio coupler pigtail connector CD-33.
2. Install the In-Line Test Box by connecting it in series with the compass system harness connector CD-33 and the radio coupler pigtail connector CD-33.
3. Position the In-Line Test Box so it is accessible for making voltage measurements.

4. Gain access to the KA-52 autopilot adapter as outlined in Section III of this manual, Removal and Installation, for the type of airplane being serviced.

5. Remove cover from KA-52 autopilot adapter (refer to Figure 5-12) to gain access to the adjustment potentiometers.

6. Center the roll command knob on the autopilot console and place the Roll engage and HDG engage switches in the "OFF" position.

7. Start airplane engine to obtain gyro stability.

8. Rotate HDG knob as required to align heading bug with lubber line at top of HSI (Horizontal Situation Indicator).

9. Rotate CRS knob as required to align the course arrow with lubber line at top of HSI.

10. Place radio coupler selector switch in the HDG mode.

11. Push Roll engage and HDG engage switches to the "ON" position.

12. Rotate HDG knob clockwise to displace heading bug 35 degrees to right of lubber line (to reach maximum signal saturation) on HSI.

13. Connect Precision Voltmeter leads to In-Line Test Box (positive lead to pin A and negative lead to pin F). Observe, AC voltage reading should be $7.0 \pm .2$ volts AC. If voltage reading is incorrect adjust HDG potentiometer of KA-52 autopilot adapter to obtain correct voltage setting.

14. Rotate HDG knob counterclockwise to displace heading bug 35 degrees to left of lubber line (to reach maximum signal saturation) on HSI.

15. With Precision Voltmeter still connected to In-Line Test Box as outlined in step 13. Observe, AC voltage reading should be $7.0 \pm .2$ volts AC. If voltage reading is correct proceed to next step. If voltage reading is incorrect adjust HDG potentiometer of KA-52 autopilot adapter to obtain correct voltage setting.

16. Rotate HDG knob as required to align heading bug with lubber line at top of HSI and remove voltmeter leads from In-Line Test Box.

17. Rotate CRS knob as required to displace course arrow at least 90 degrees to the right of the on course heading.

18. Connect Precision Voltmeter leads to In-Line Test Box (positive lead to pin B and negative lead to pin C). Observe, AC voltage reading should be $7.0 \pm .2$ volts AC. If voltage reading is incorrect adjust CRS potentiometer of KA-52 autopilot adapter to obtain correct voltage setting.

19. Rotate CRS knob as required to displace course arrow at least 90 degrees to the left of the on course heading.

20. With Precision Voltmeter still connected to In-Line Test Box as outlined in step 18. Observe, AC voltage reading should be $7.0 \pm .2$ volts AC. If voltage is correct proceed to next step. If voltage reading is incorrect adjust CRS potentiometer of KA-52 autopilot adapter to obtain correct voltage setting.

21. This completes the alignment procedure for the KA-52 autopilot adapter.

22. Disengage autopilot and shut down airplane engine.

23. Disconnect Precision Voltmeter leads from In-Line Test Box and remove In-Line Test Box from airplane.

24. Connect KCS-55 harness connector CD-33 to radio coupler pigtail connector CD-33.

25. Install cover on KA-52 autopilot adapter and secure.

26. Refer to paragraph 5-14 for AltiMatic IIIC Flight Adjustment Procedure with Radio Coupler (Roll).

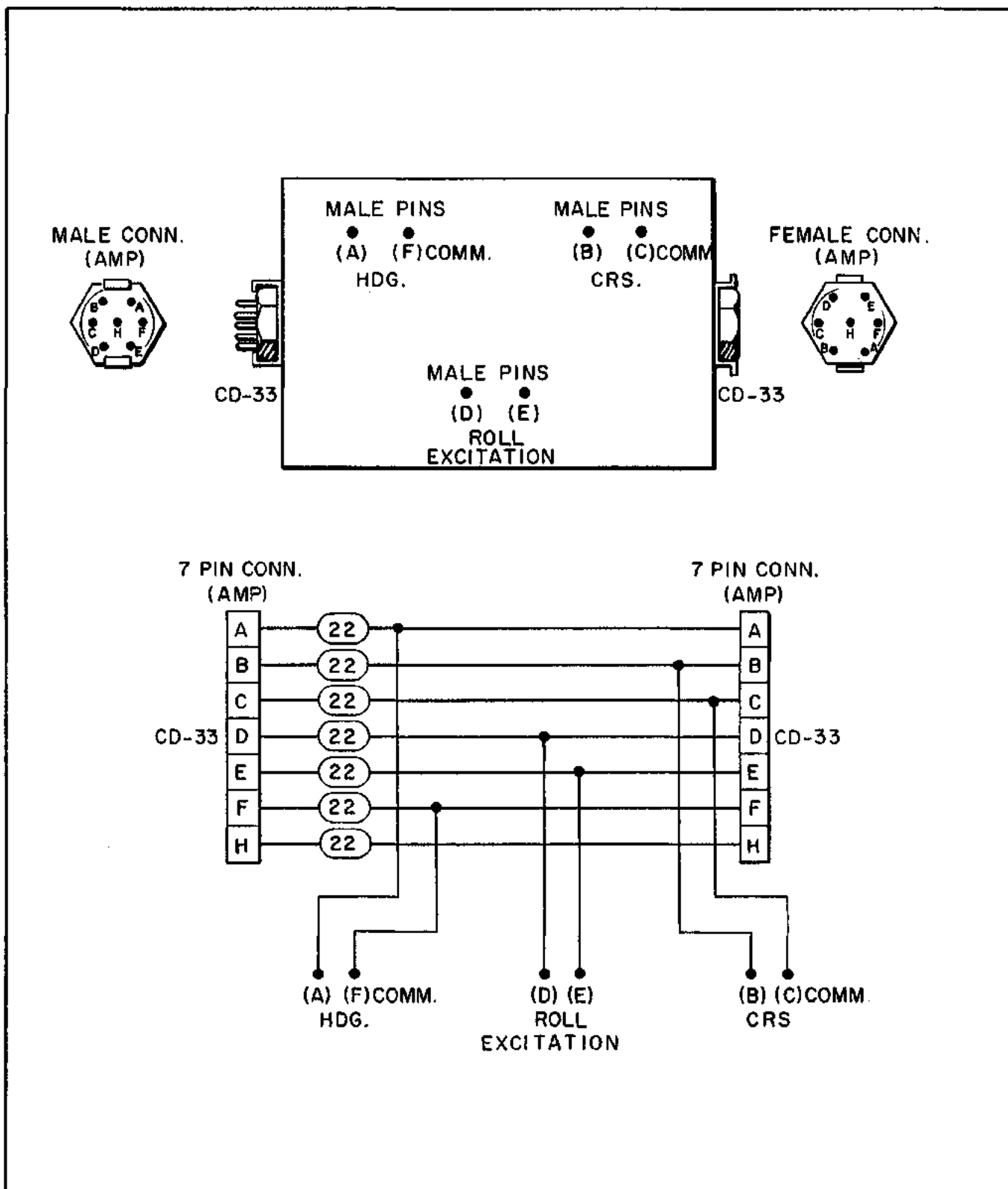

Figure 5-11. In-Line Test Box (Locally Fabricated)

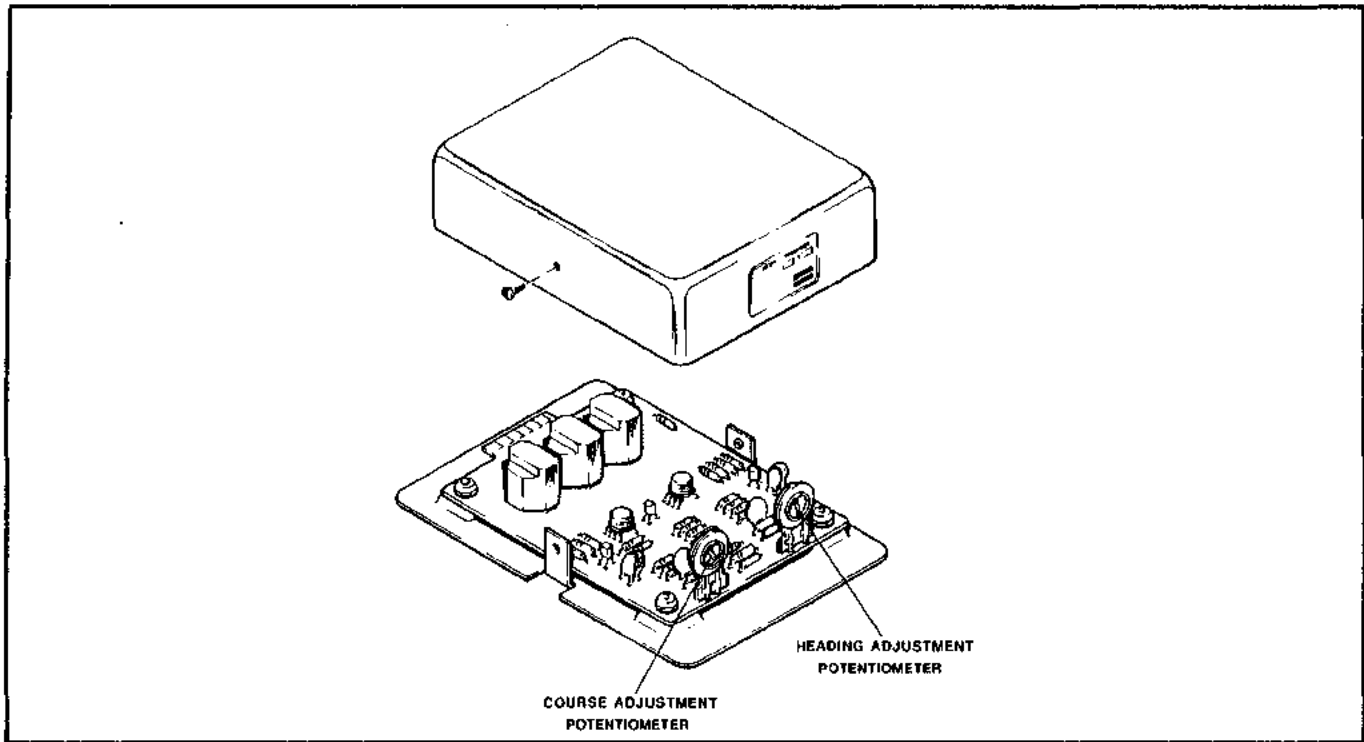

Figure 5-12. KA-52 Autopilot Adapter

➔ 5-22. YAW DAMPER GROUND CHECK.

The Yaw Damper consists of four components: the Yaw Damper Amplifier (which contains the rate gyro, electrolytic potentiometer, and the servo amplifier); the Rudder Servo; the Yaw Damper ON-OFF Switch and Control Wheel disconnect switching; and the interconnecting wiring harness.

The Logic Chart is designed to help locate and isolate, an in-aircraft system problem without dismantling the system. (Refer to Fig. 5-13 and Fig. 5-14 for Bench Test hook-up and wiring diagrams in Section VI.)

TABLE V-III. TROUBLE ISOLATION BLOCK DIAGRAM

IN AIRCRAFT TROUBLESHOOTING
LOGIC CHART

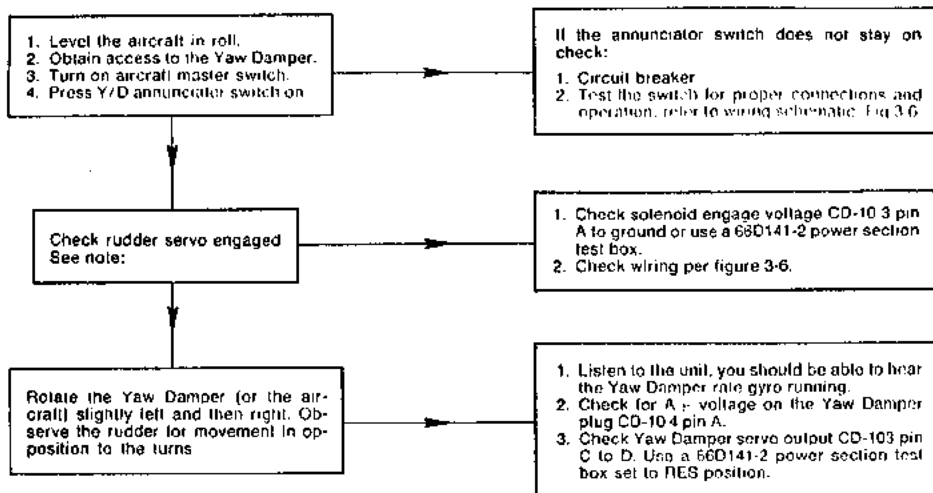

NOTE: Because of nose wheel steering/rudder interconnect in some aircraft, it may be necessary to observe the rudder servo while it is engaged to be sure it is operating properly.

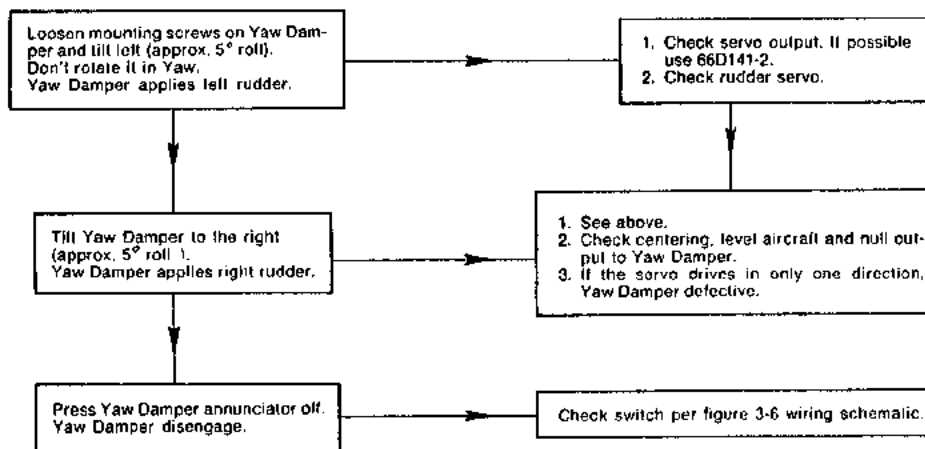

With the aircraft leveled in roll; adjust the pot on the front of the 1C651-() for a zero output to the Yaw servo motor. Use a 66D141-2 power section or equivalent meter to monitor servo motor voltage.



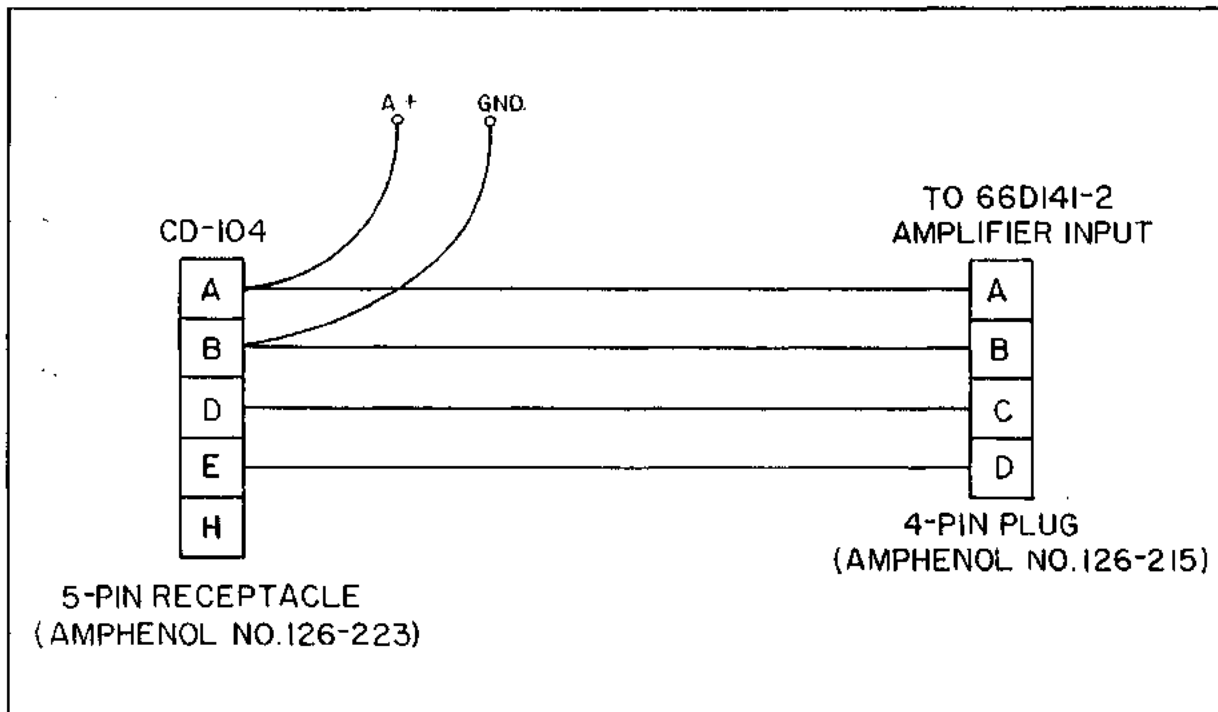

Figure 5-13. Bench Test Wiring Harness
Yaw Damper

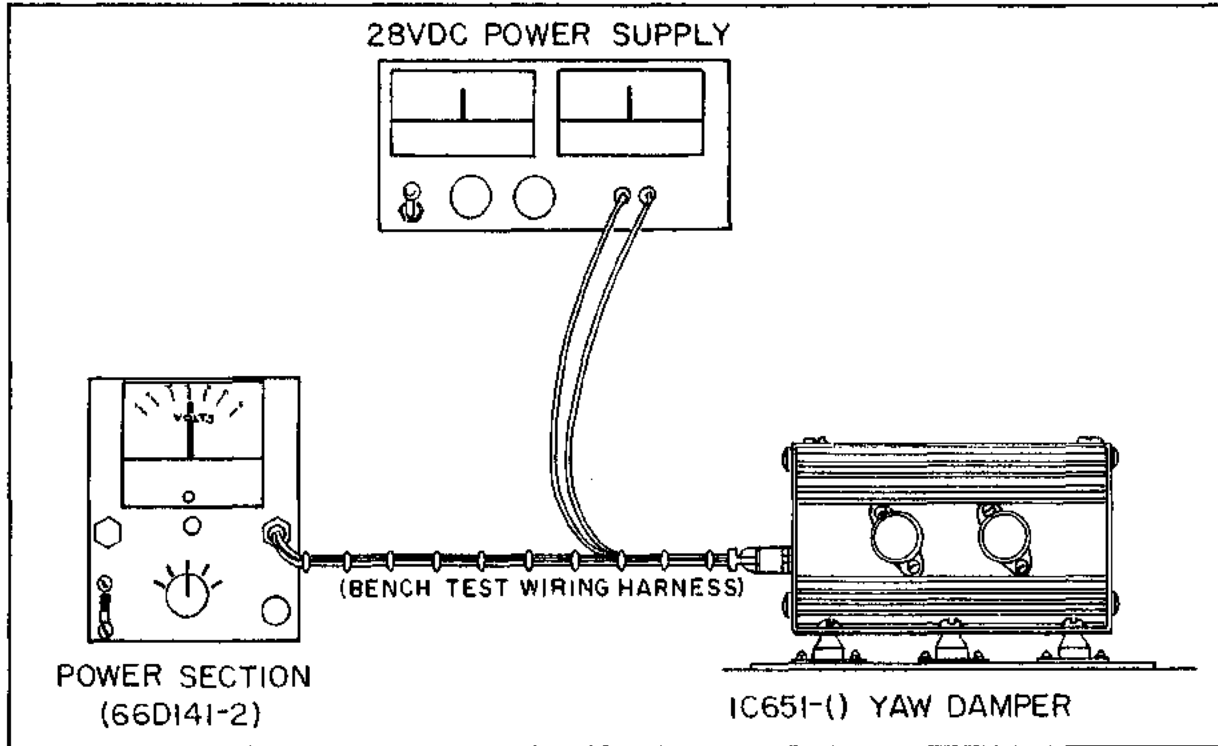

Figure 5-14. Test Equipment Hook-Up
Yaw Damper

SECTION VI
WIRING DIAGRAMS

Paragraph	Page
6-1. Introduction	6-1

SECTION VI

WIRING DIAGRAMS

6-1. INTRODUCTION. This section of the manual consists of wiring diagrams of the electrical harnesses and mating connectors of the AltiMatic IIC Autopilot. The wiring diagrams should be utilized for troubleshooting the system for defective wiring and mating connectors. A continuity test of the system can be performed with an ohmmeter. This test will clarify the harness is good and capable of carrying current. Should any wire or connector fail to produce a reading on the ohmmeter, they are defective and must be replaced. Refer to the following pages for the Wiring Diagrams for the AltiMatic IIC installations on the various Piper airplanes.

Figure 6-1. Altimatic III C Block Diagram, PA-23-250 (six place) E & F (up to S/N 27-7754002) Models

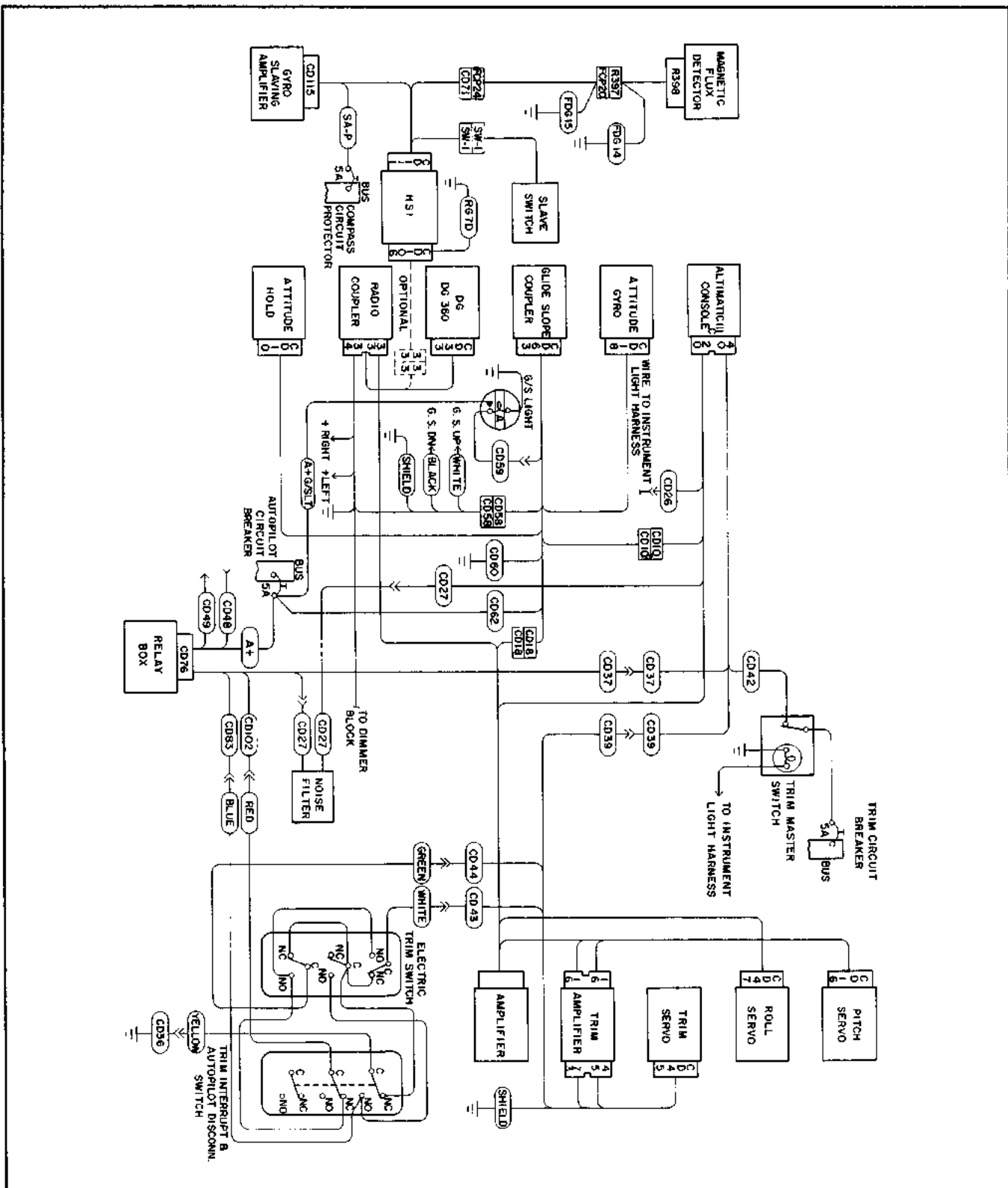

15647-B

Figure 6-3. Altmatic III C Block Diagram, PA-31-310 and PA-31-325

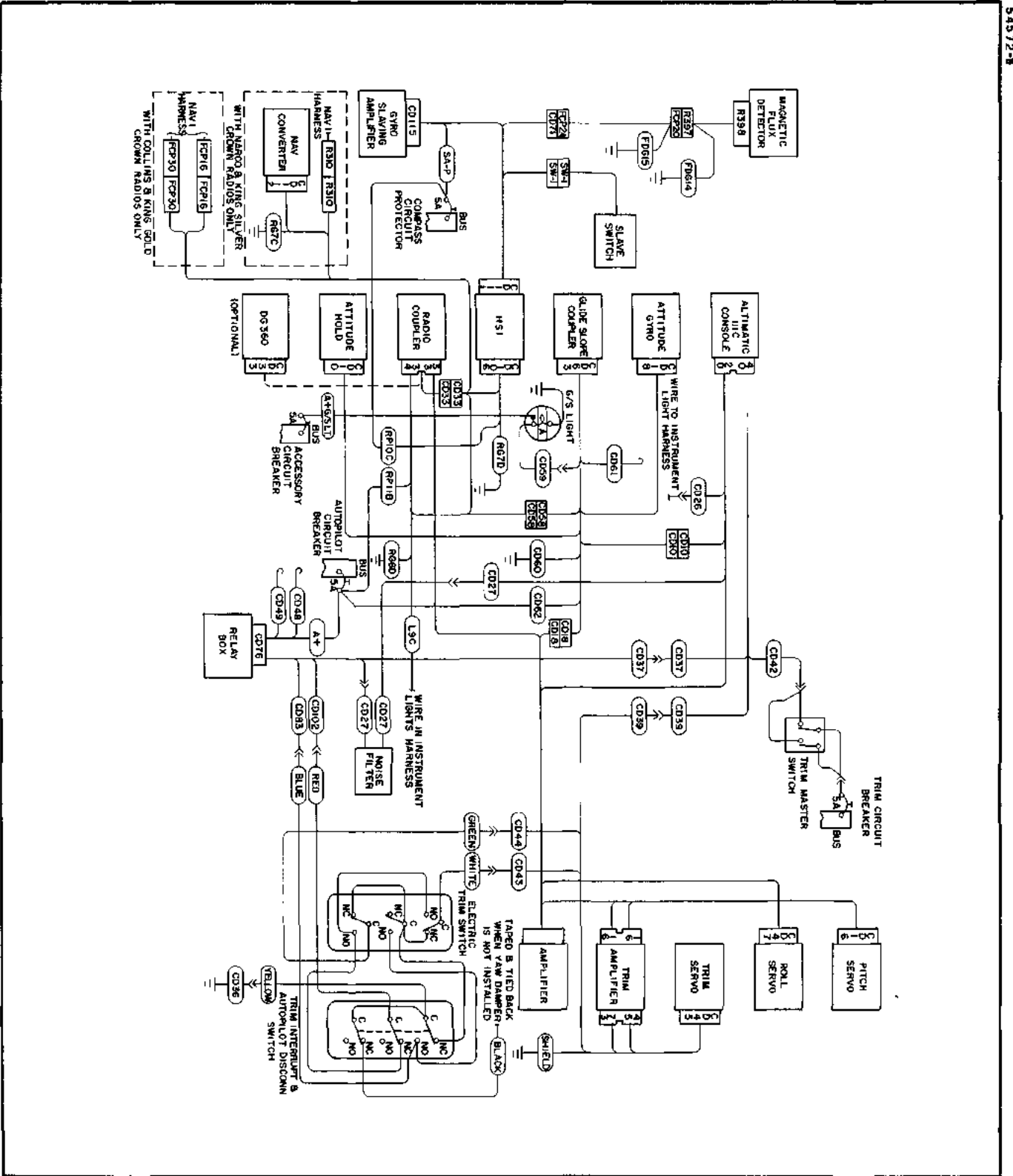
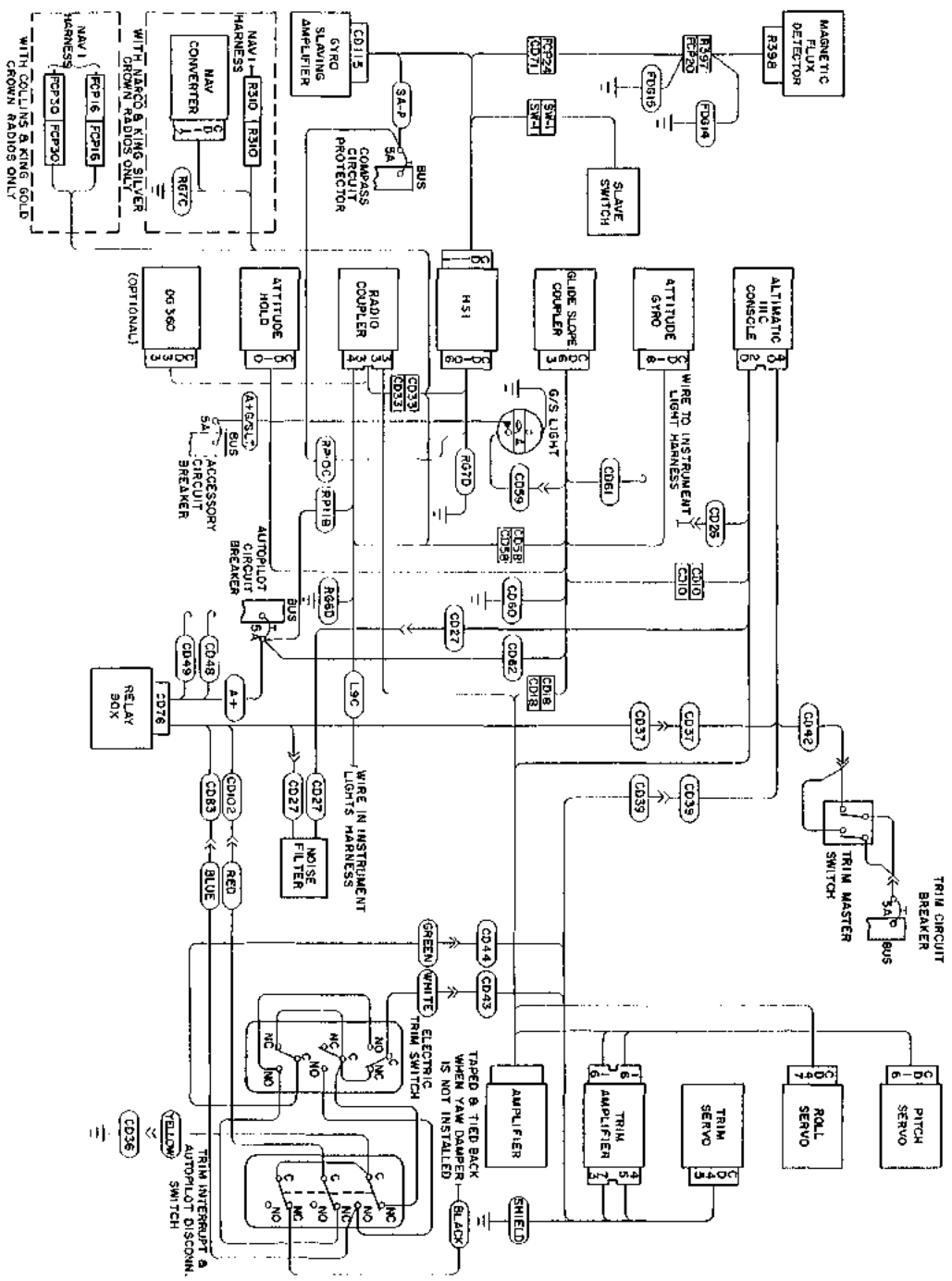
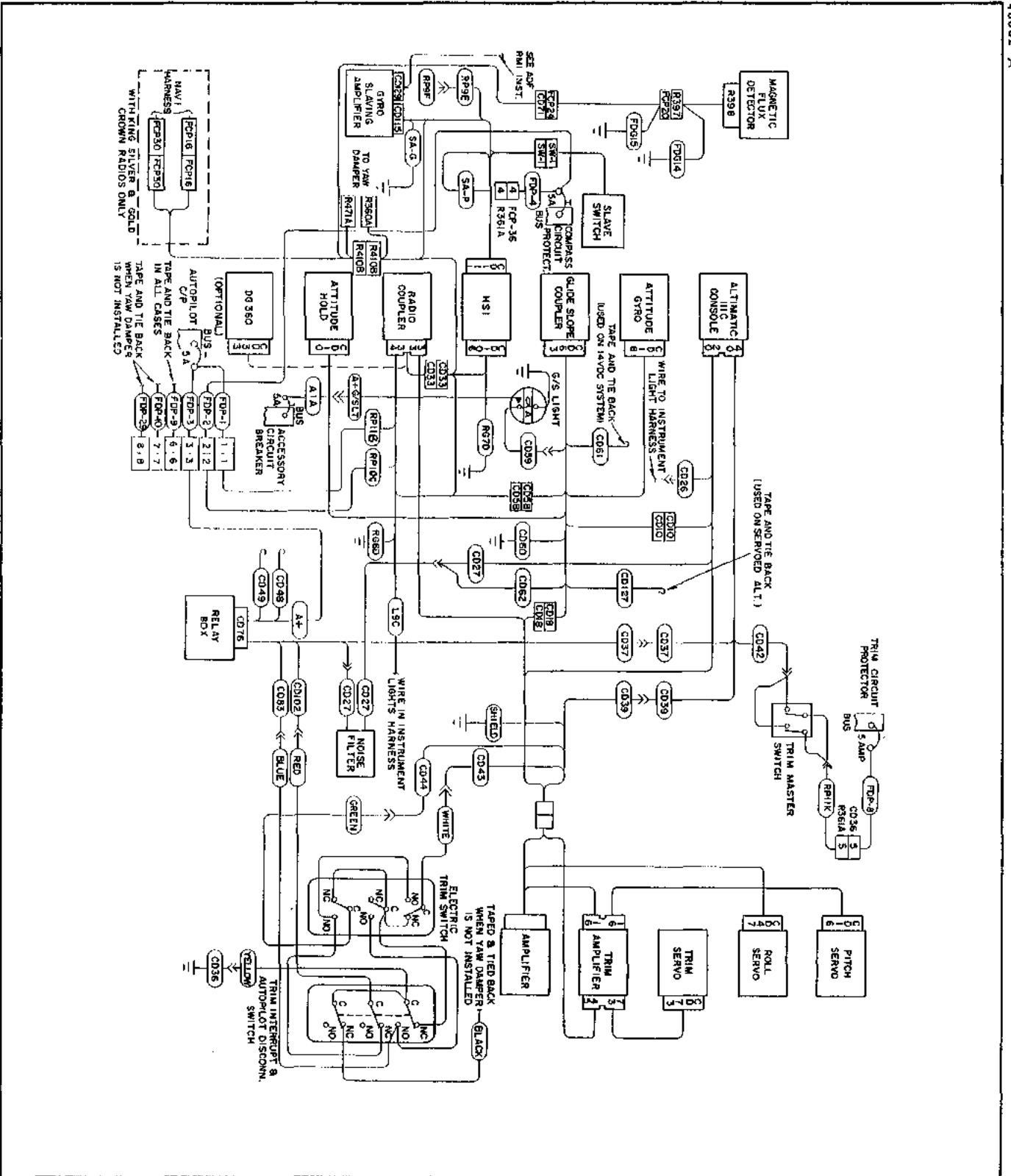

Figure 6-4. Altimatec IIC Block Diagram, PA-31-350



54512-8

Figure 6-5. Altimatec IIC Block Diagram, PA-31P



48832-A

Figure 6-7. Altmatic IIC Block Diagram, PA-34-200T and PA-44-180

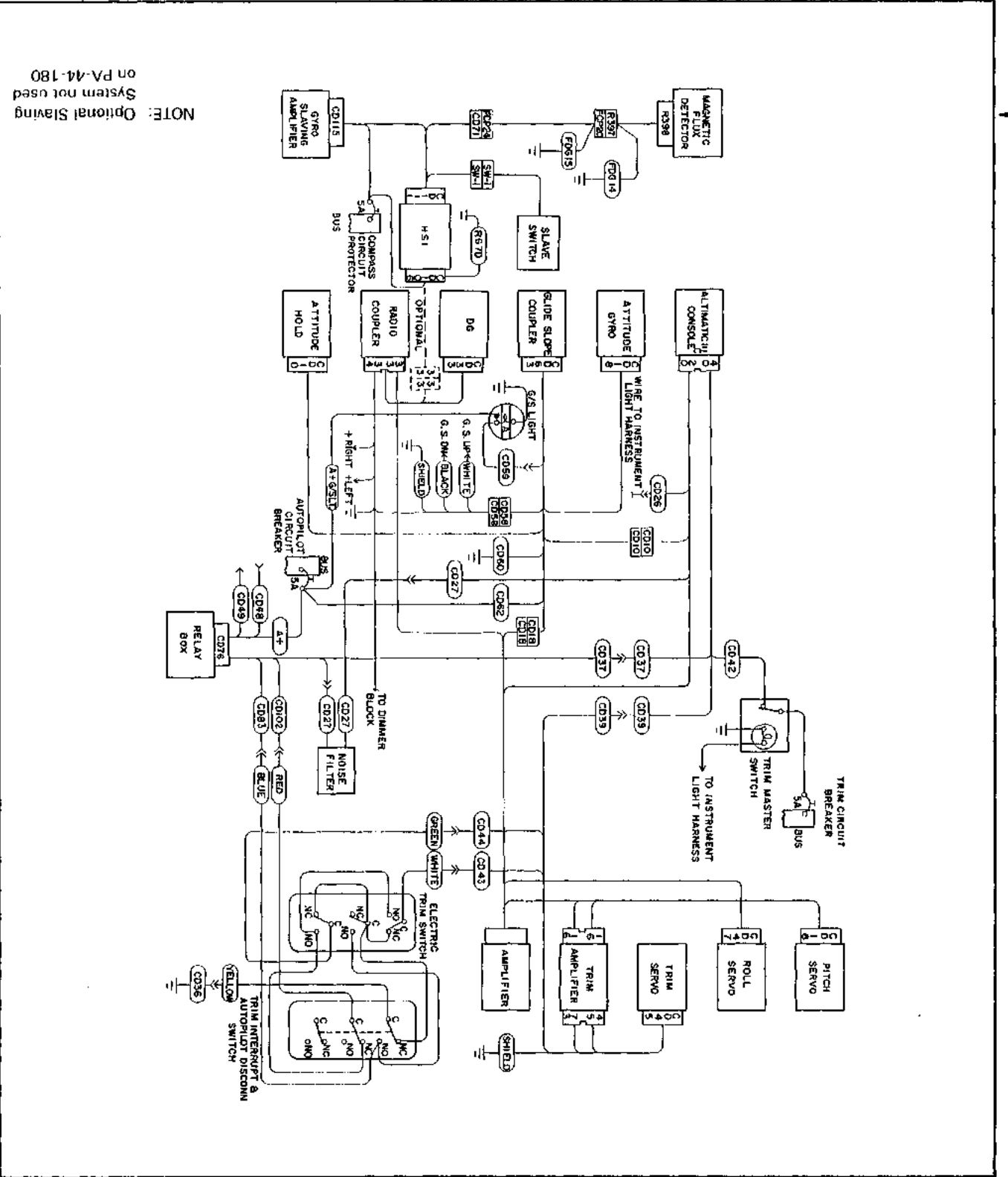

NOTE: Optional Slaving System not used on PA-44-180

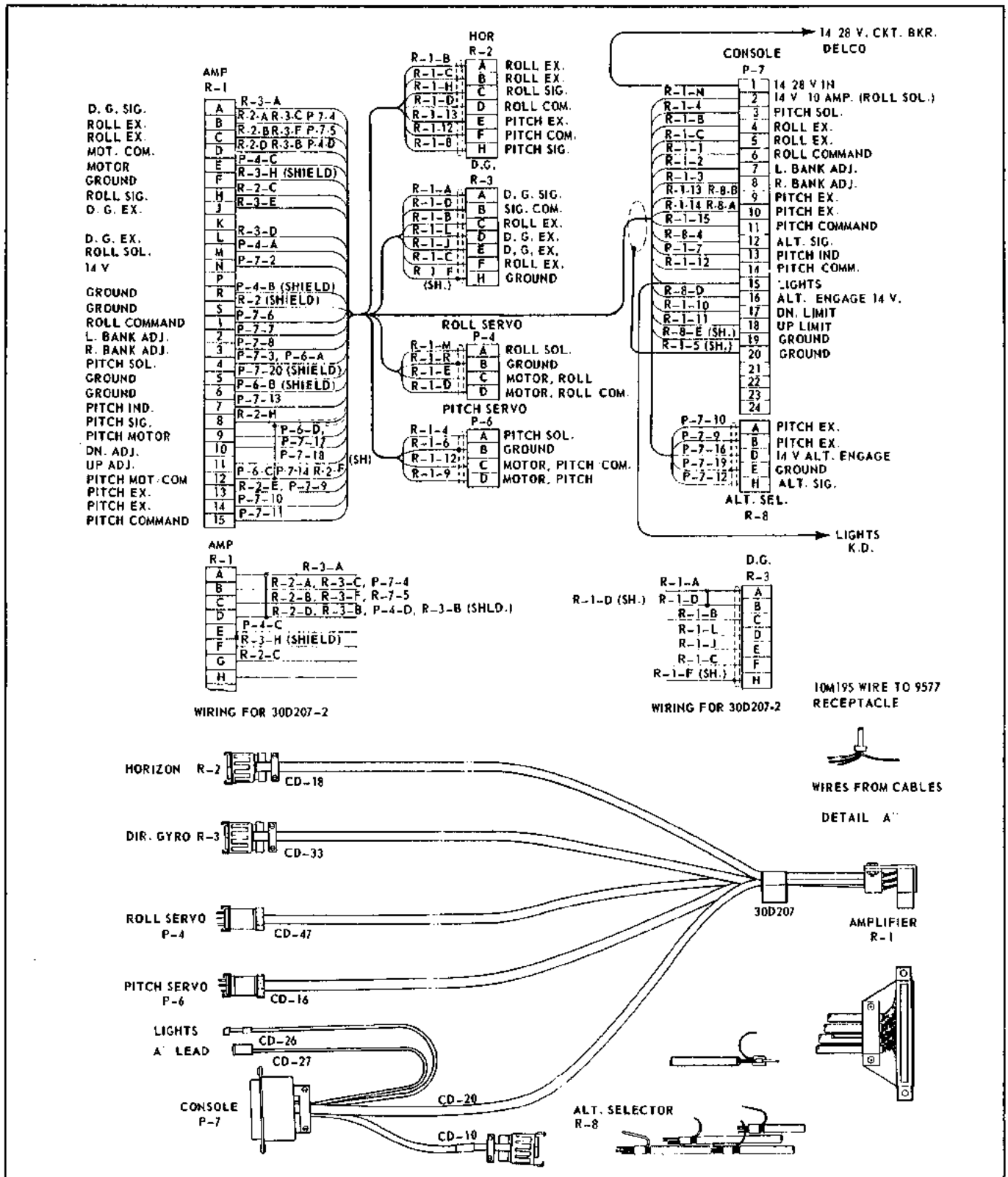

Figure 6-8. AltiMatic IIC Harness

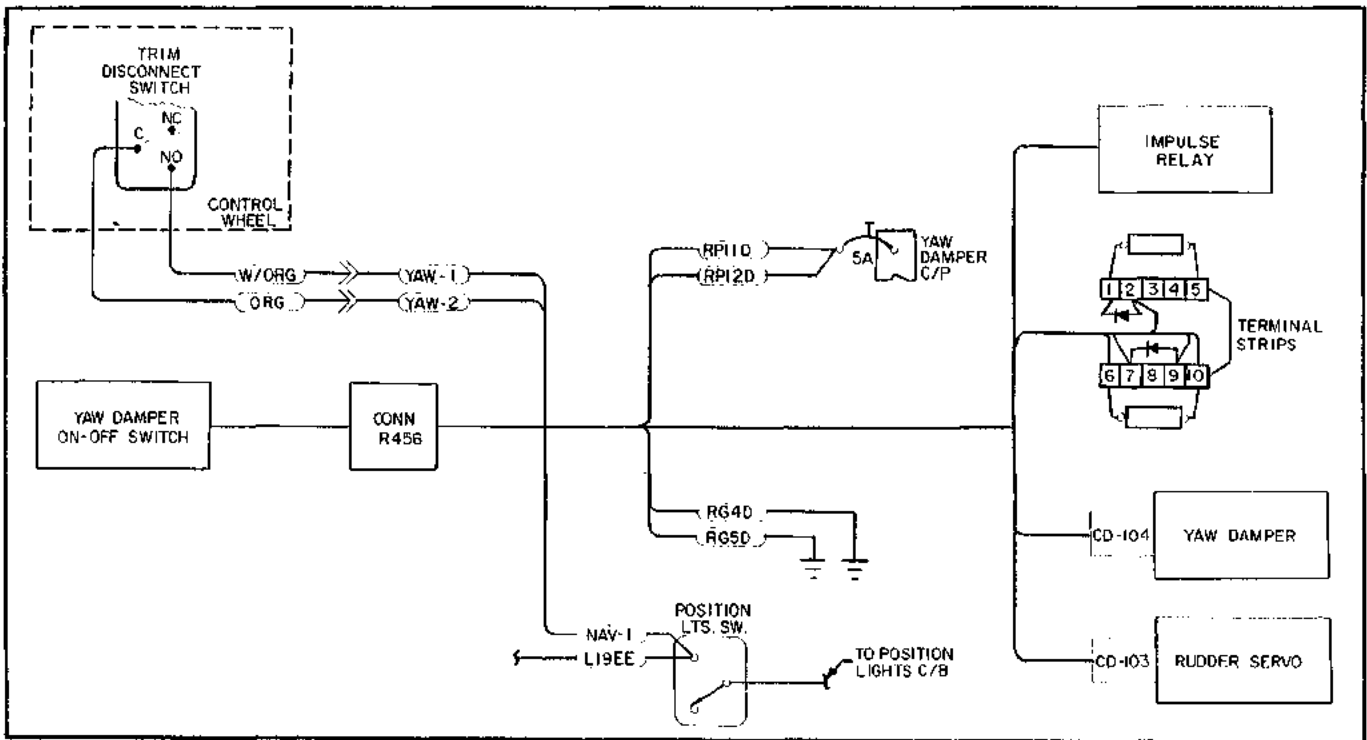

Figure 6-8a. Yaw Damper Block Diagram, PA-31-310, PA-31-325 and PA-31-350

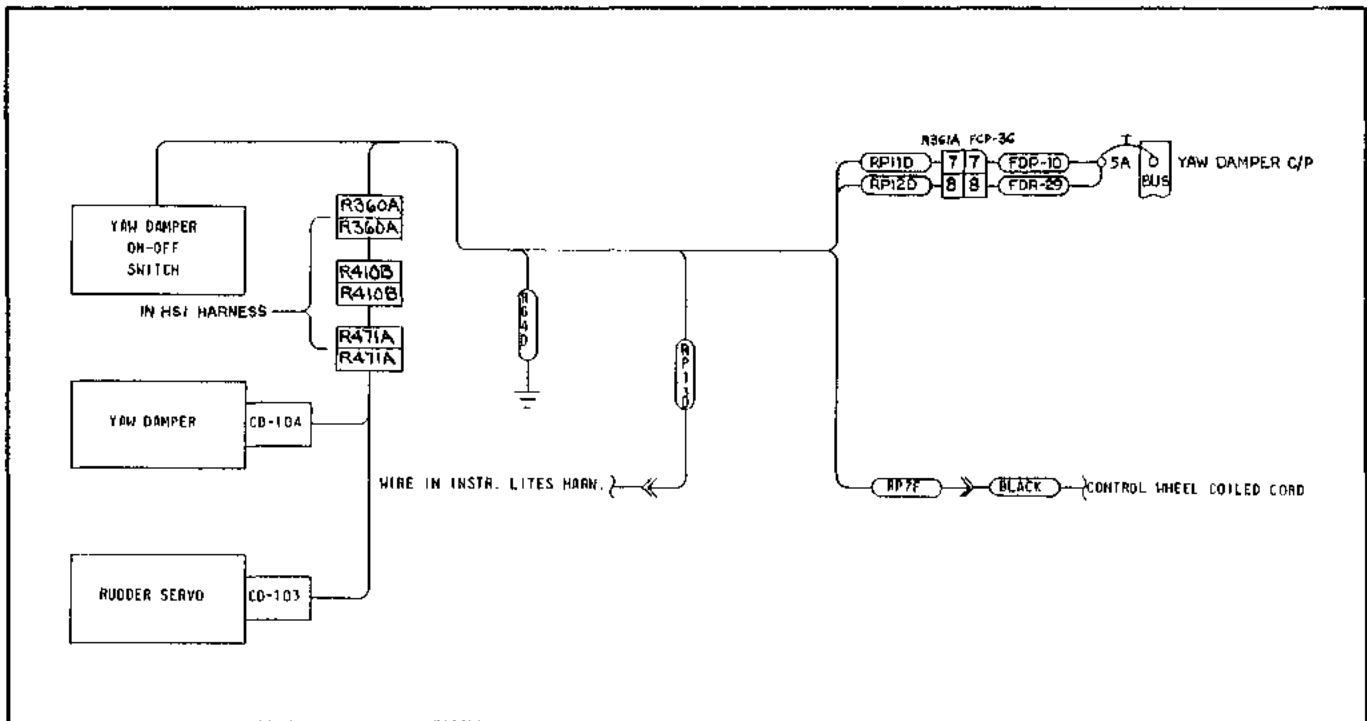

Figure 6-8b. Yaw Damper Block Diagram, PA-31P

84549

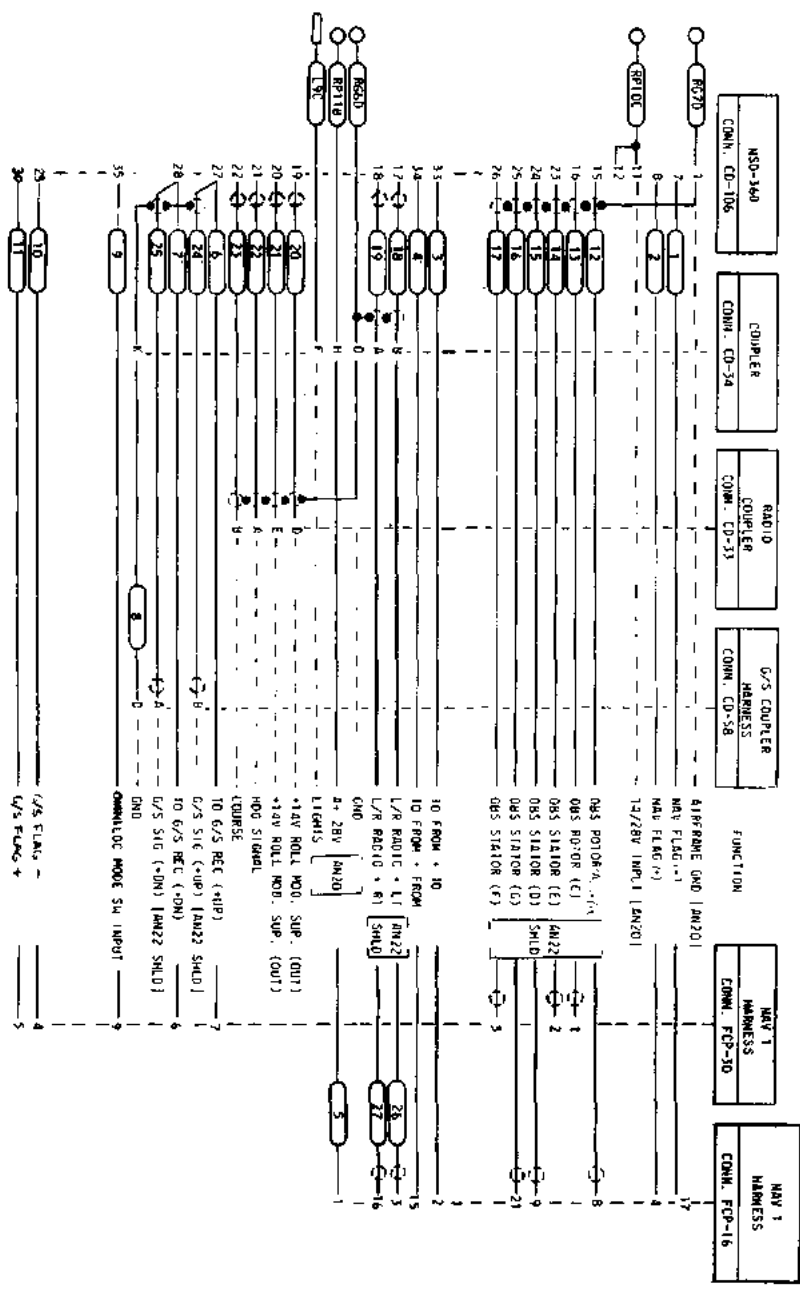
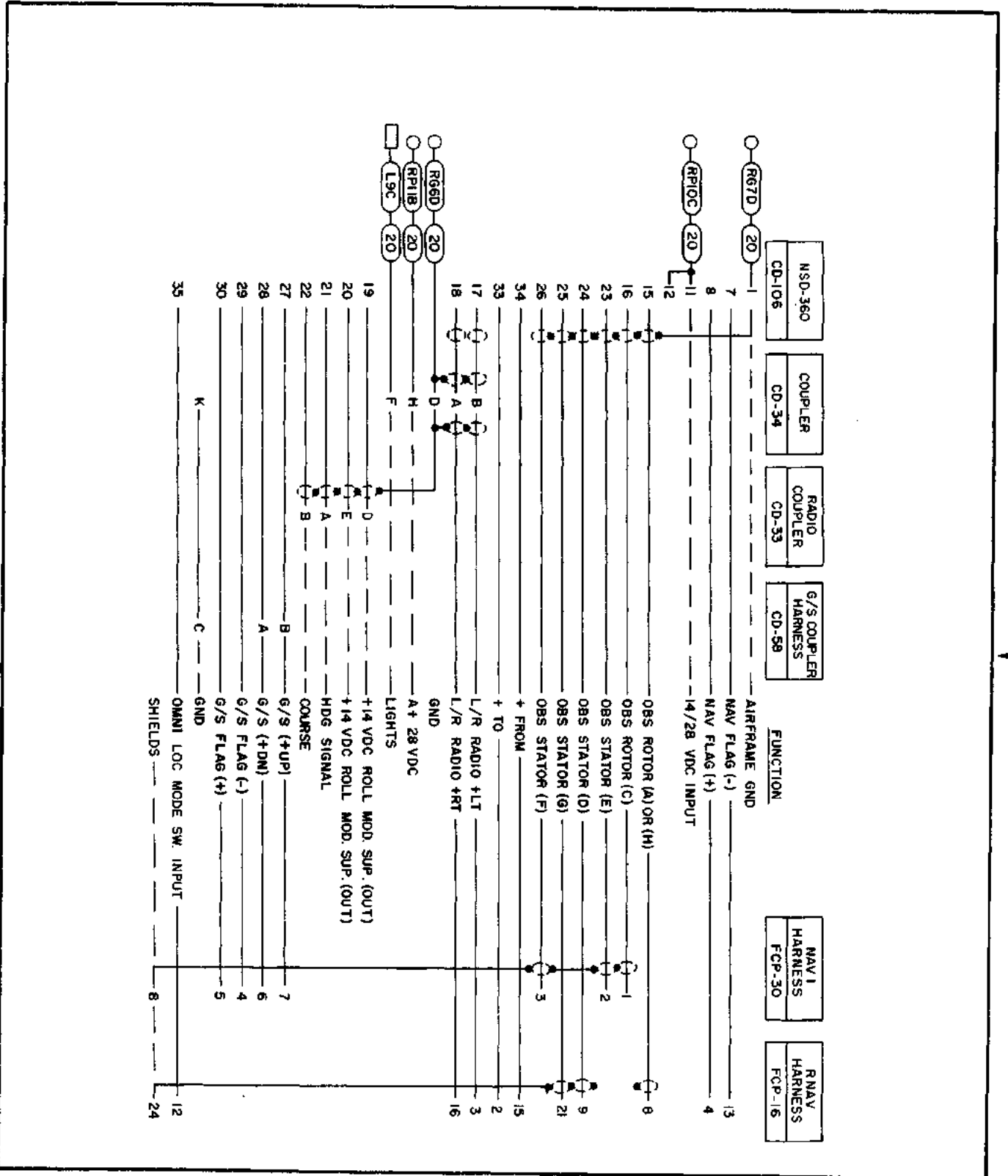
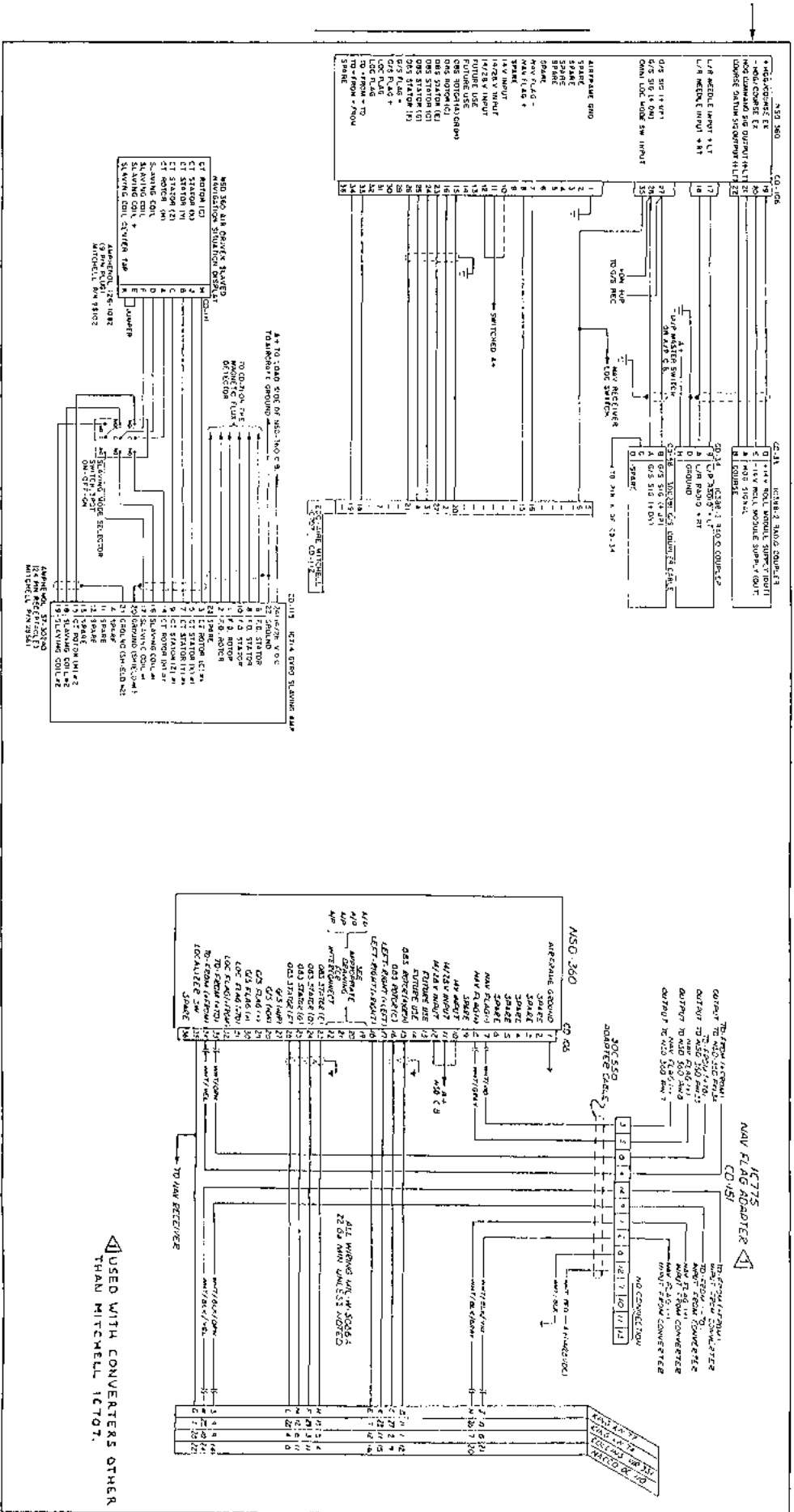

Figure 6-11. Horizontal Situation Indicator Harness (Optional) without IC707

WIRING DIAGRAMS
REVISED: 8/10/78

Figure 6-11a. Horizontal Situation Indicator Harness (Optional) With RNAV





WIRING DIAGRAMS
REVISED: 3/10/78

Figure 6-12. Horizontal Situation Indicator Schematic Staved (Optional)

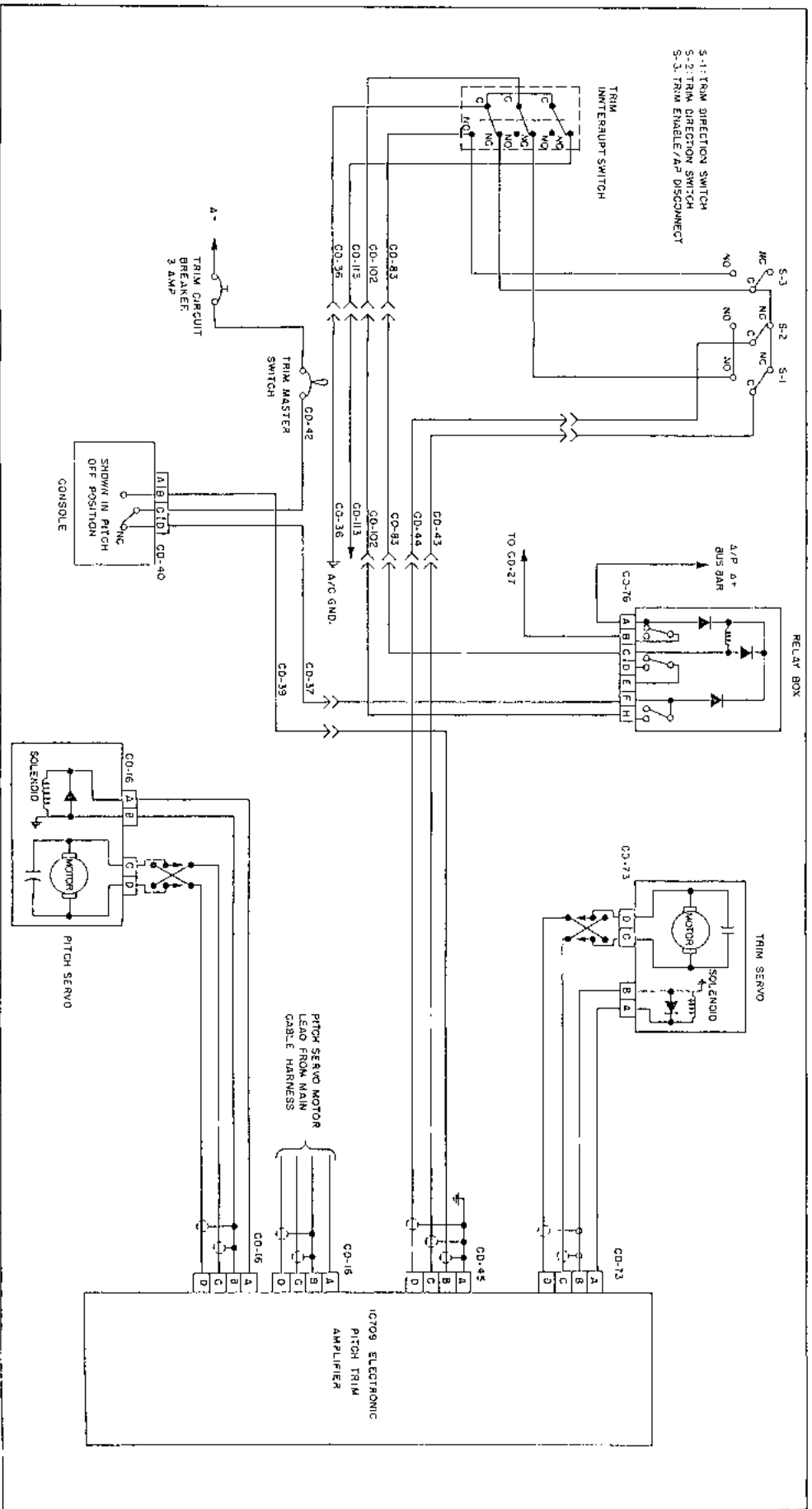

Figure 6-13. Electronic Trim System Schematic

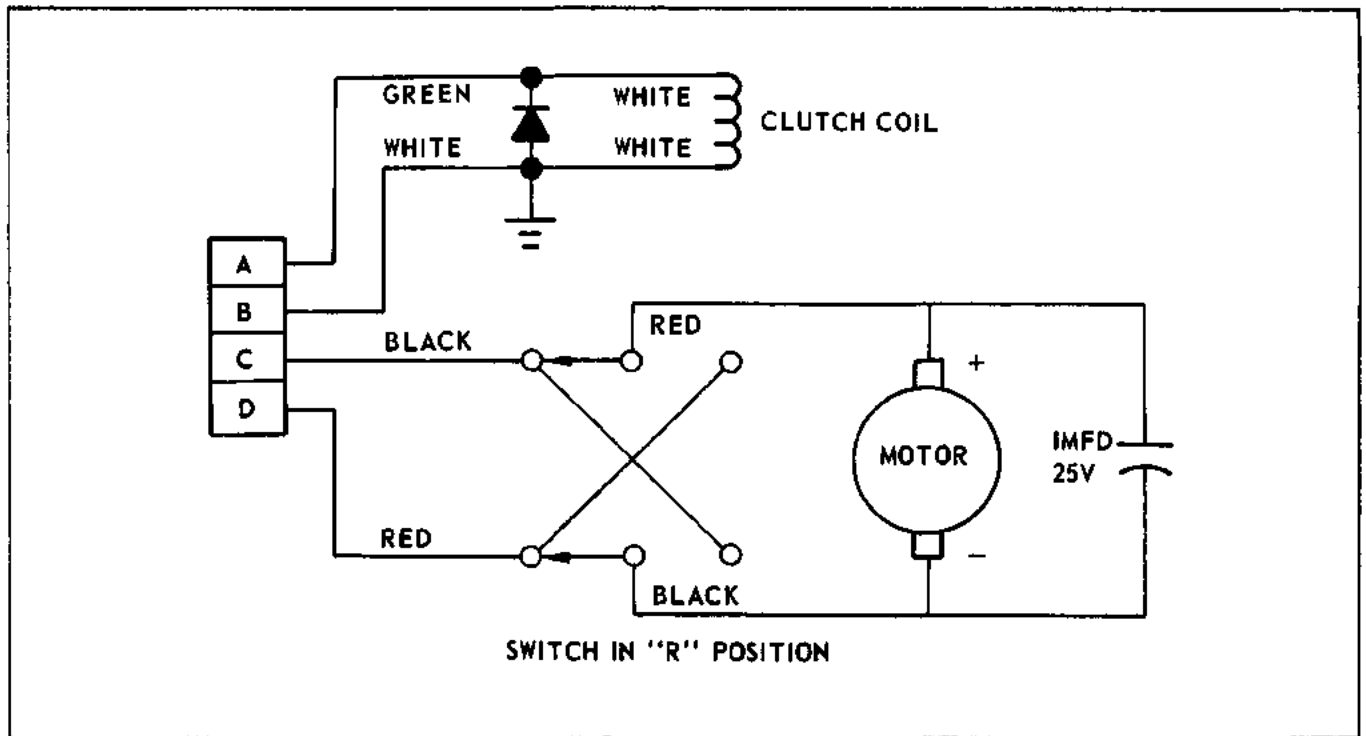

Figure 6-14. Servo Schematic

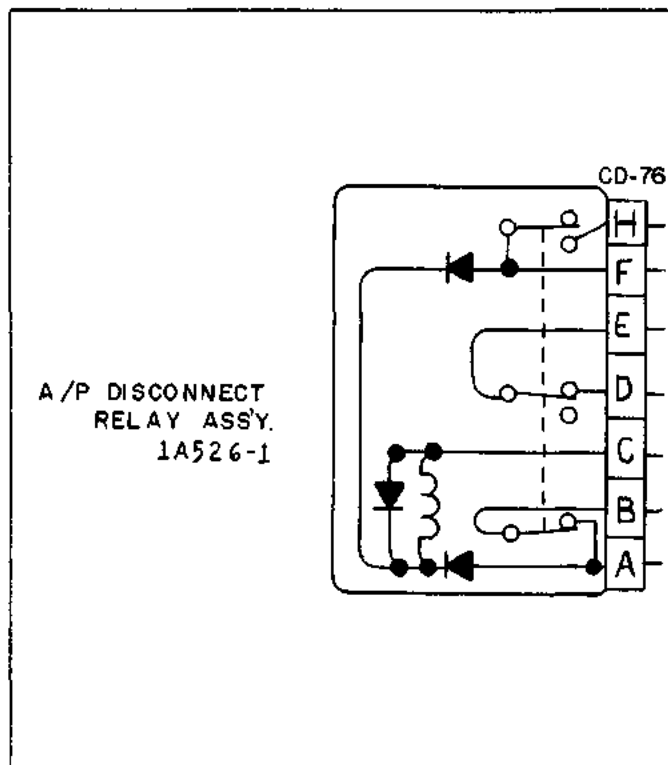

Figure 6-15. Relay Box Schematic

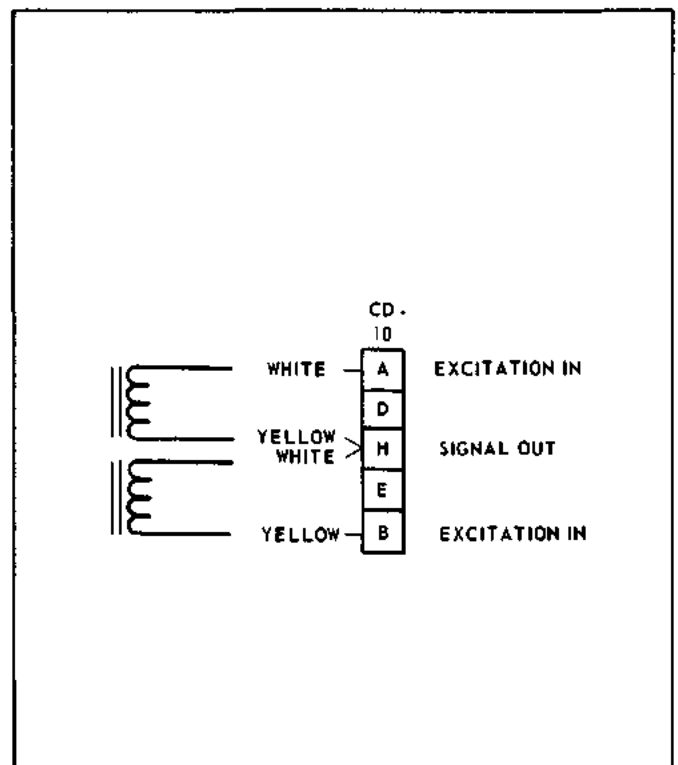

Figure 6-16. Altitude Hold Unit Schematic

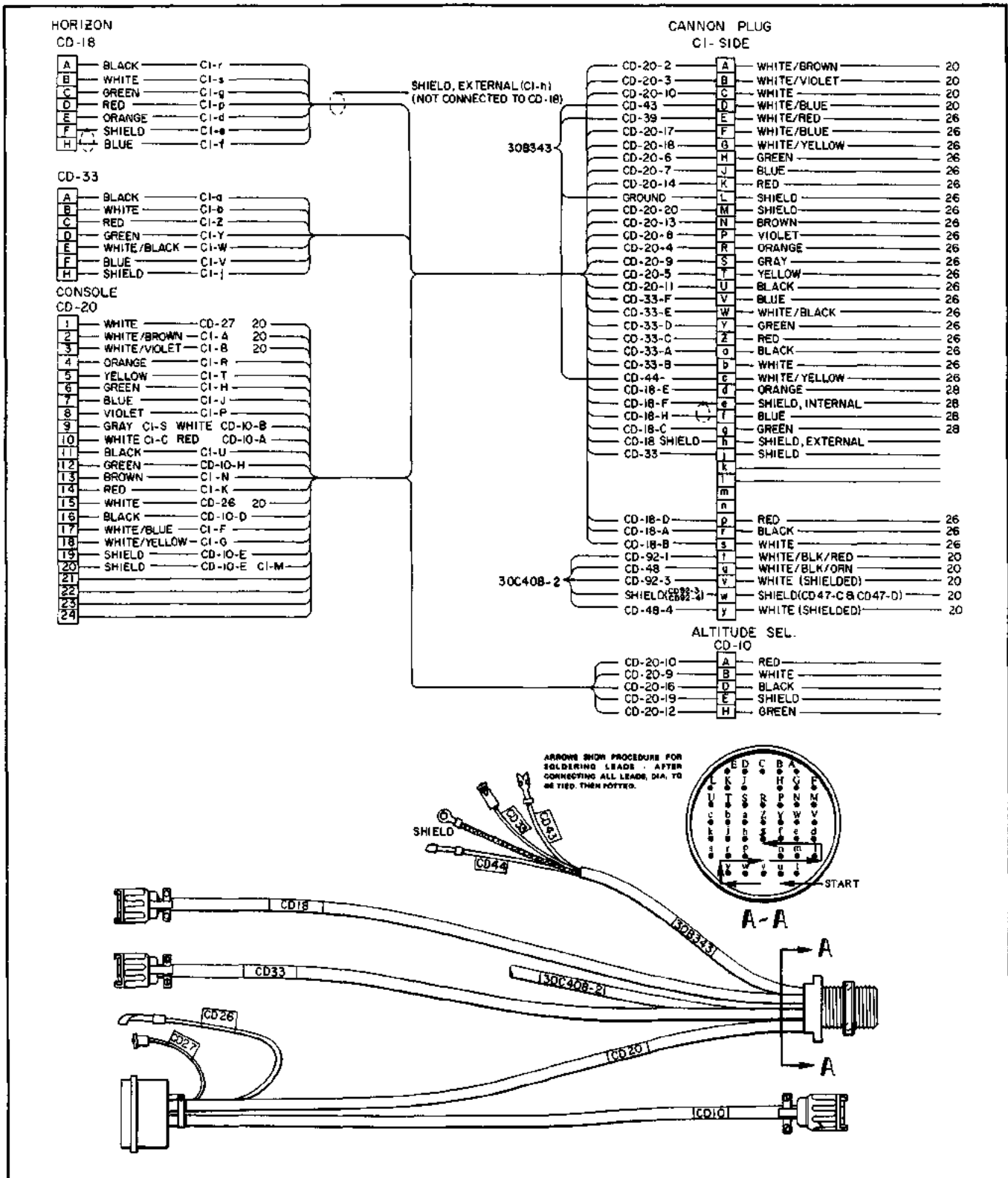

Figure 6-17. AltiMatic IIC Pressure Bulkhead Connectors (PA-31P)

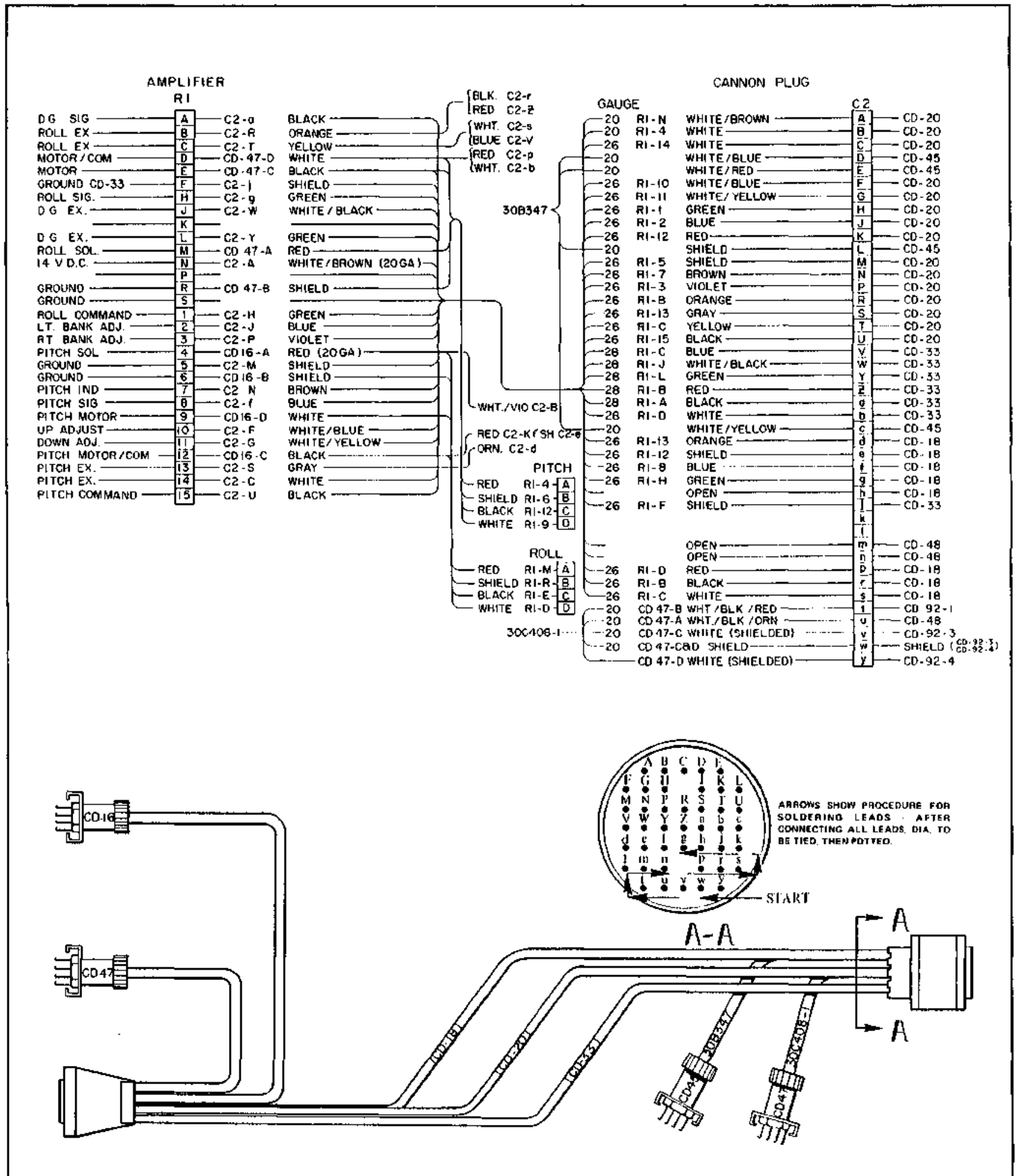

Figure 6-17. AltiMatic IIC Pressure Bulkhead Connectors (PA-31P) cont.

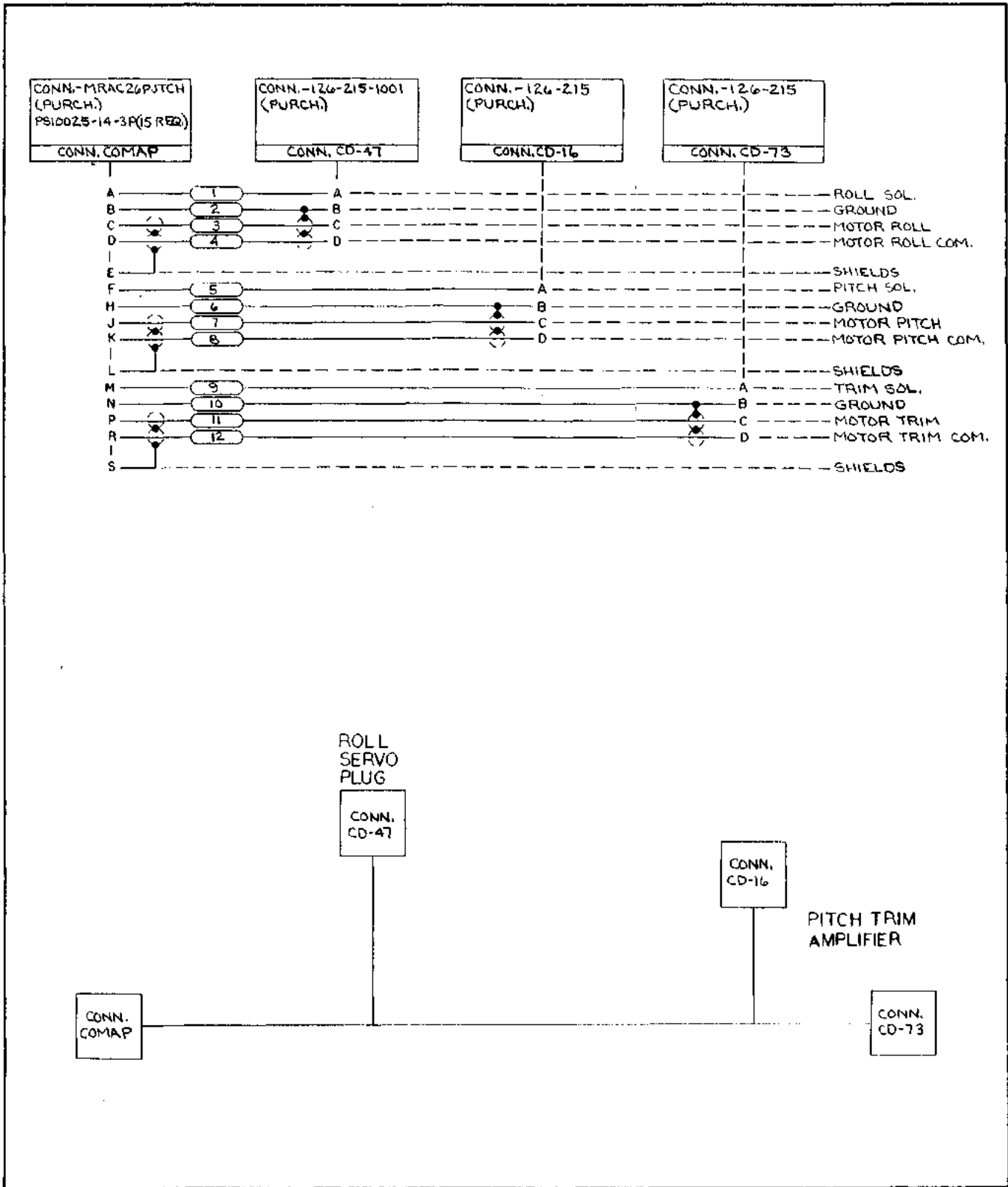

Figure 6-18. Servo, ALT IIC A/P Harness, PA-23-250 (Six Place)

28277-2

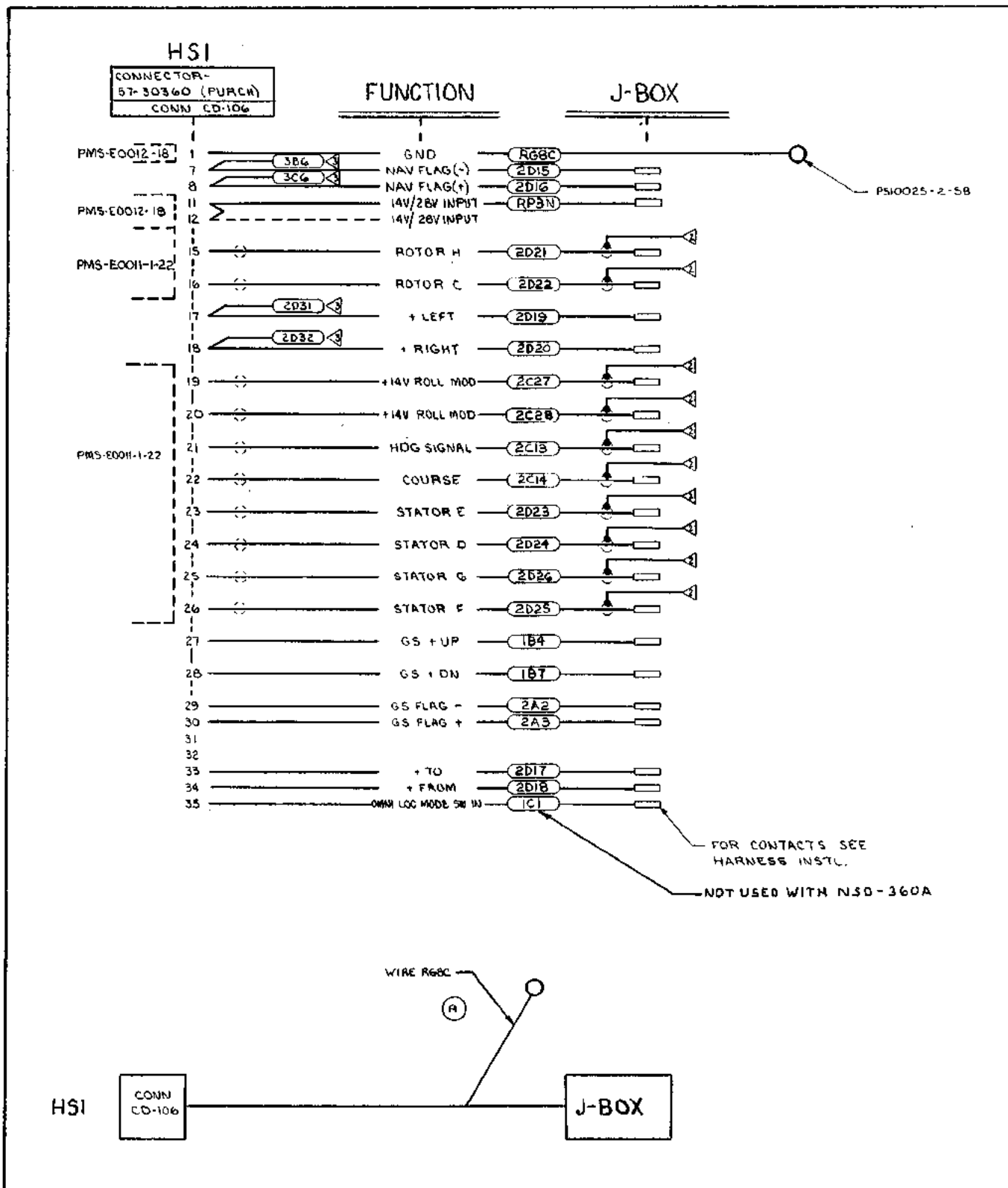

Figure 6-19. HSI Harness, PA-23-250 (Six Place)

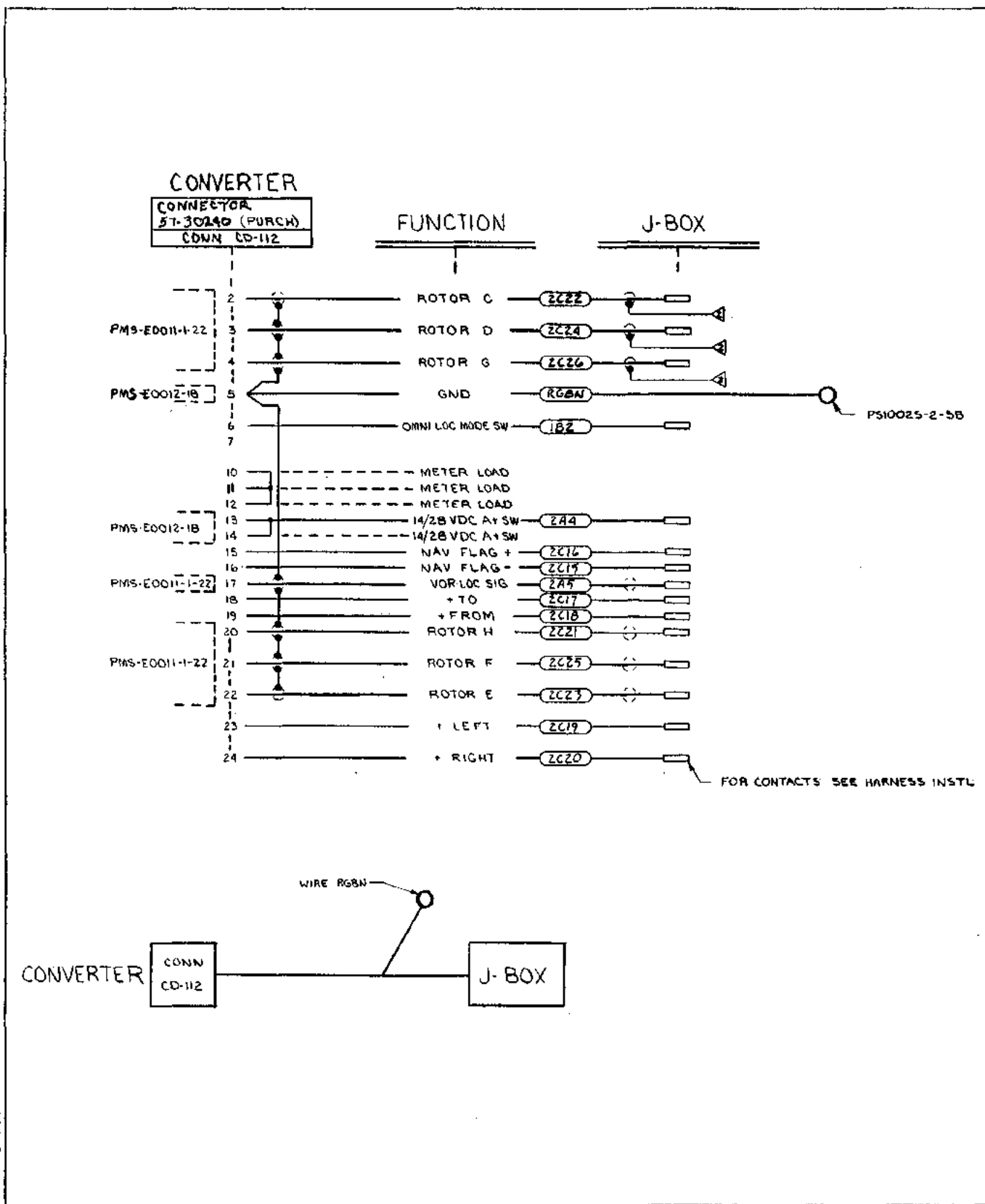

Figure 6-20. Converter Harness, PA-23-250 (Six Place)

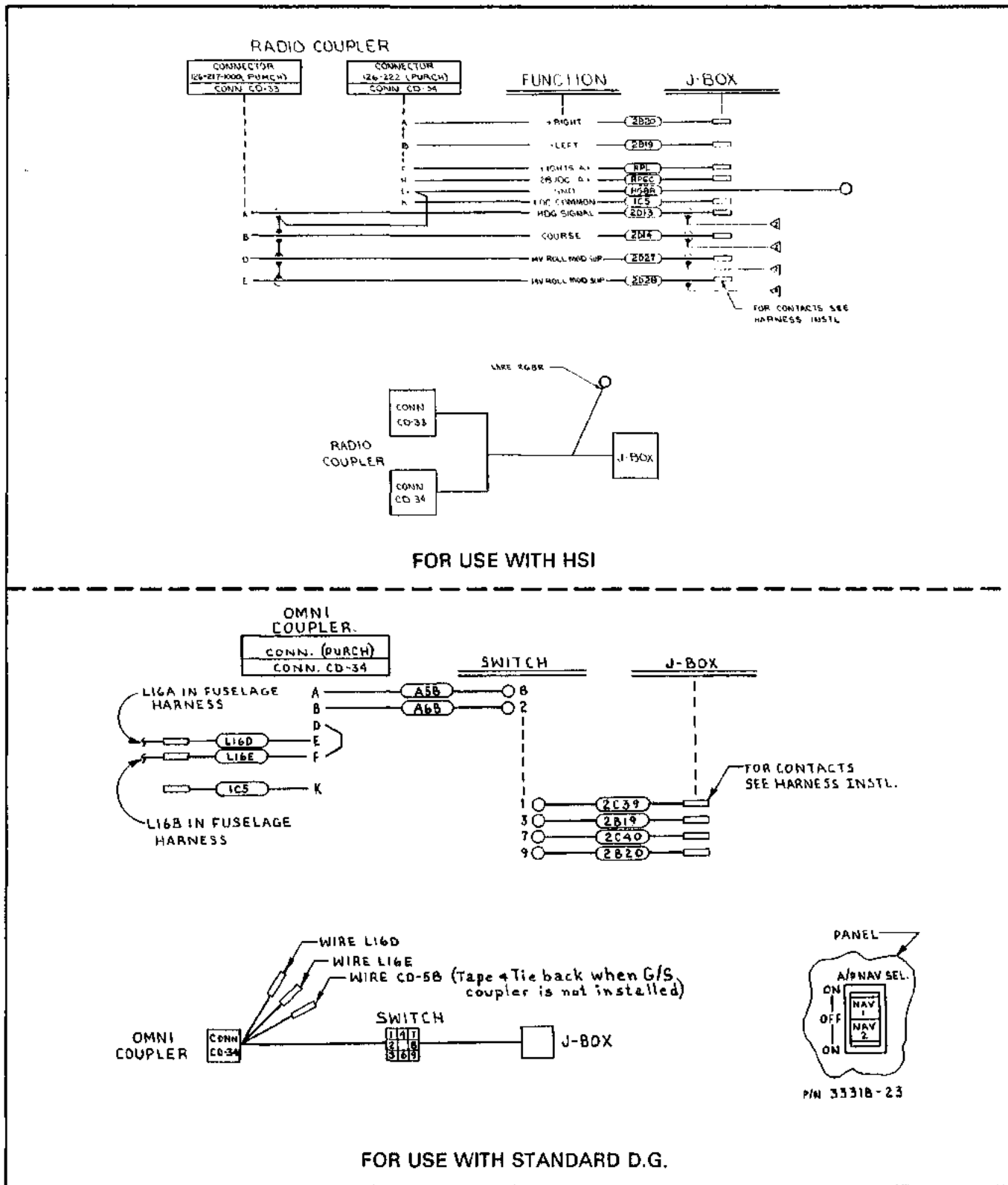

Figure 6-21. Radio Coupler Harness, PA-23-250 (Six Place)

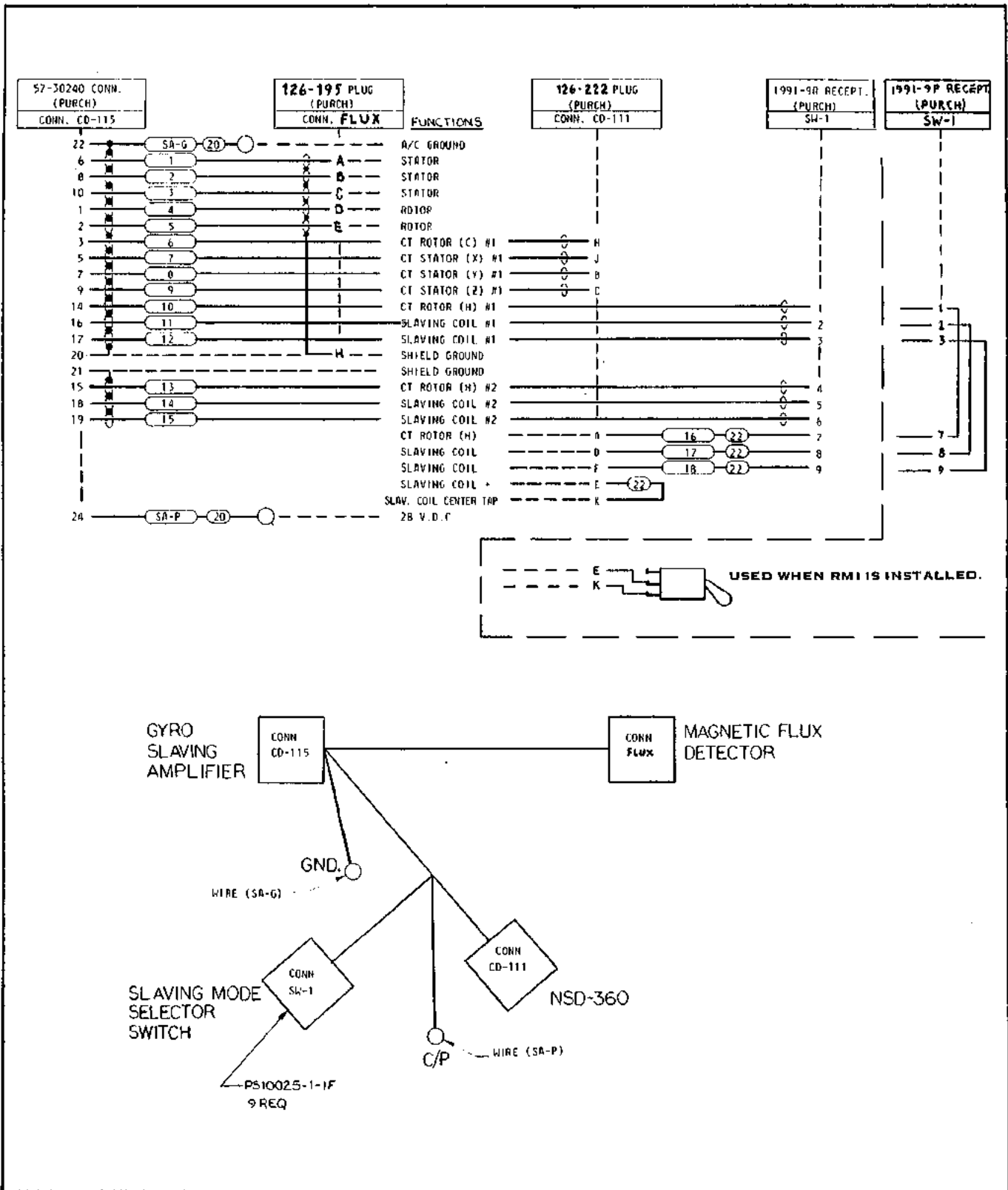
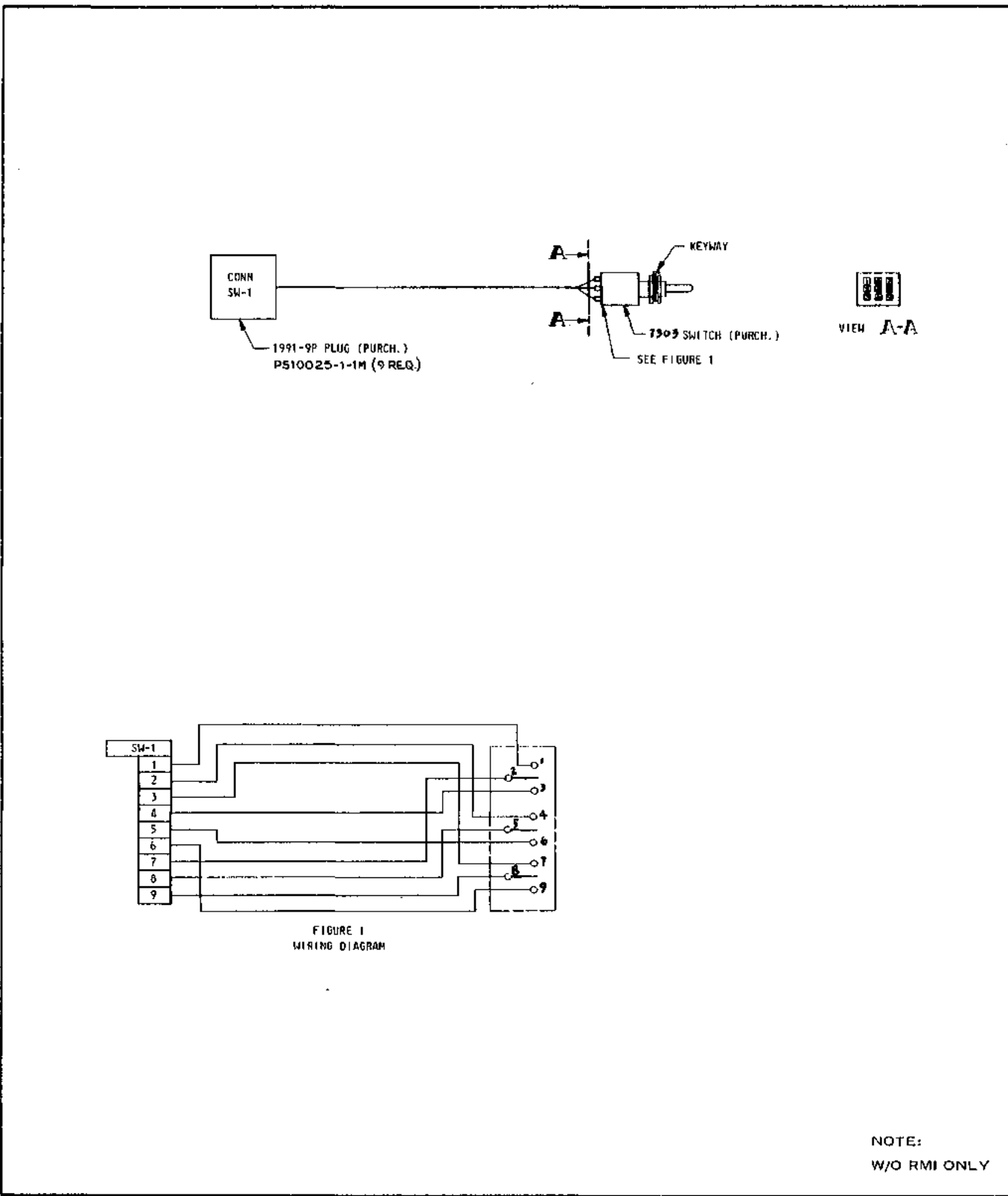

Figure 6-22. Gyro Slaving Harness, PA-23-250 (Six Place)



15640-2-C

Figure 6-23. Slaving Switch Harness, PA-23-250 (six place), PA-31-310; -325; -350 and PA-31P

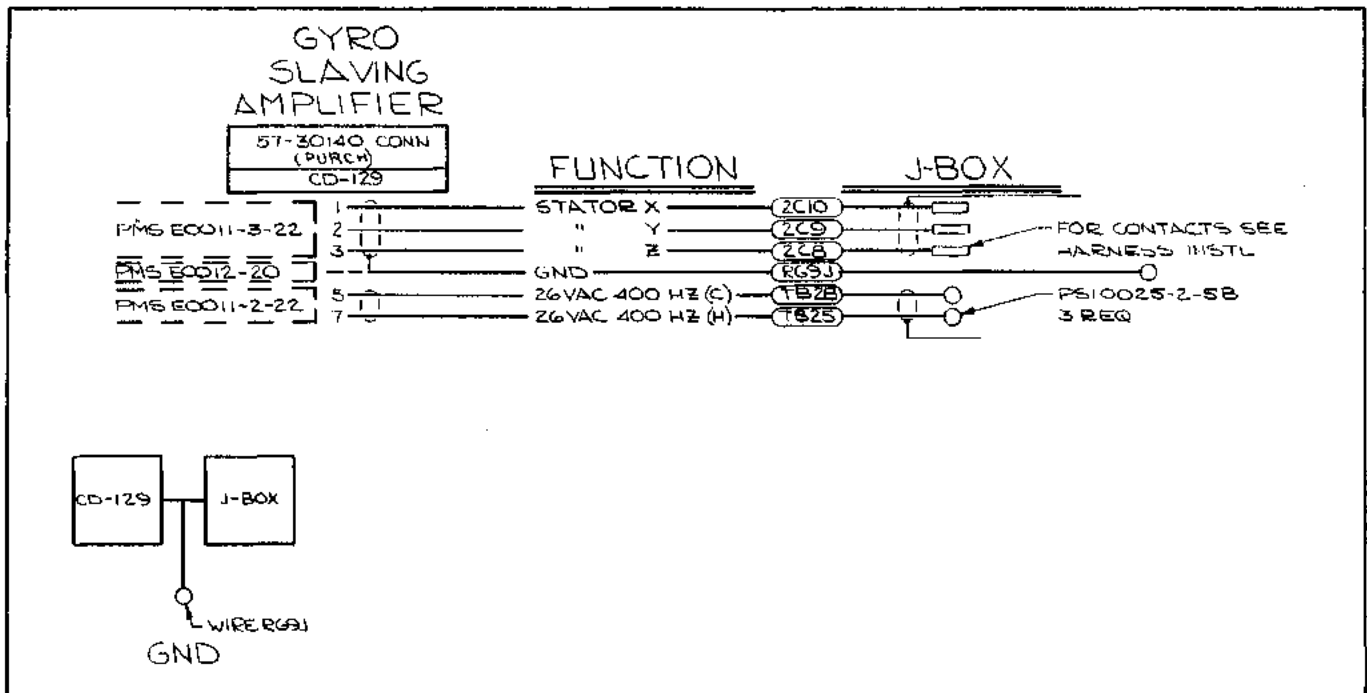

Figure 6-24. RMI Boot Strap Harness, PA-23-250 (Six Place)

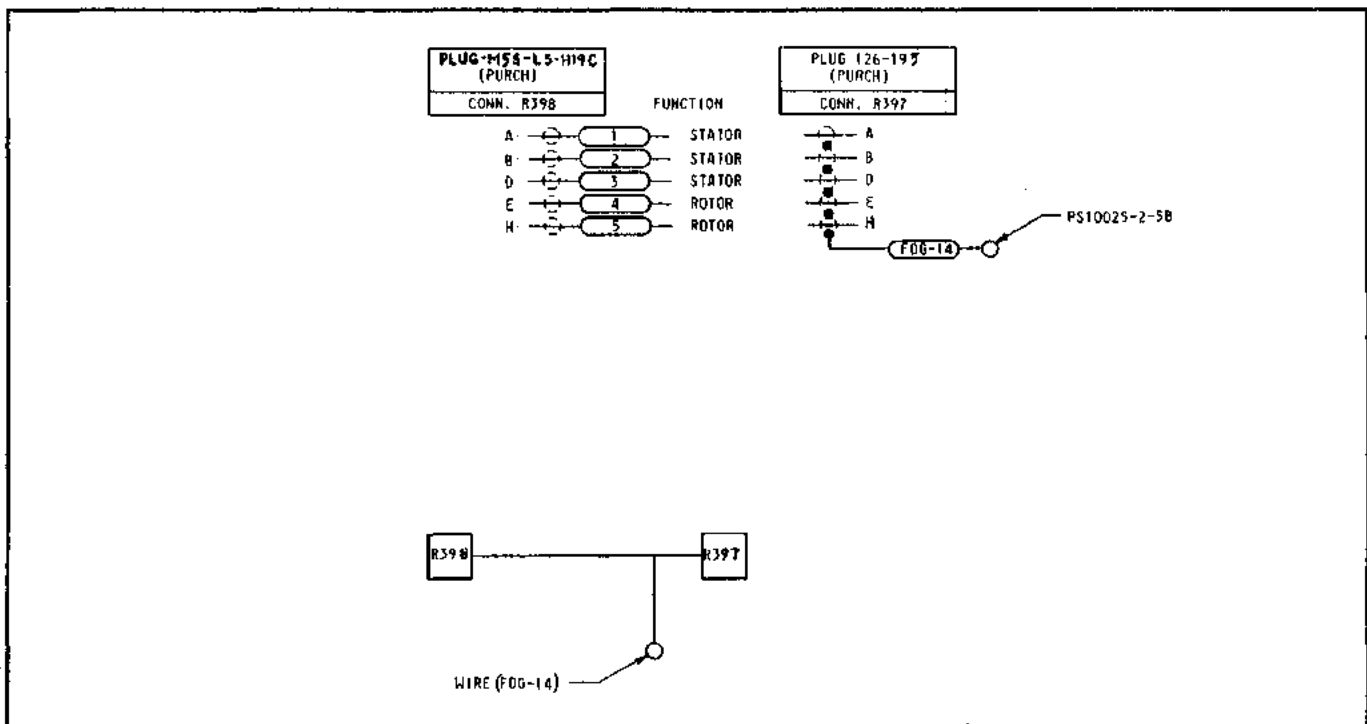

Figure 6-25. Flux Sensor Harness, PA-31-310; -325; -350 and PA-31P

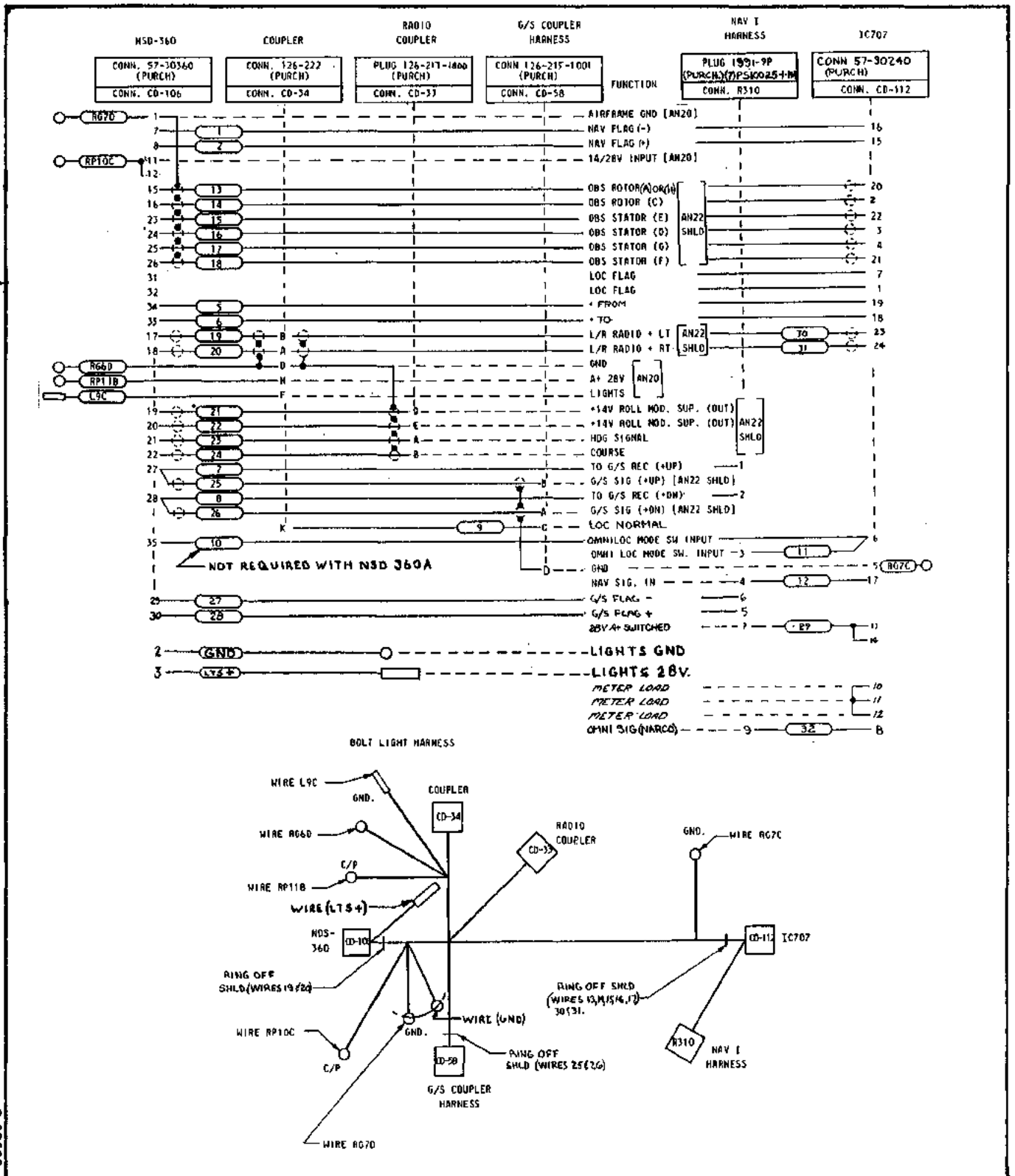

Figure 6-26. HSI, EDO AIRE Mitchell Harness, PA-31-310; -325 and -350

PIPER ALTIMATIC IIC SERVICE MANUAL

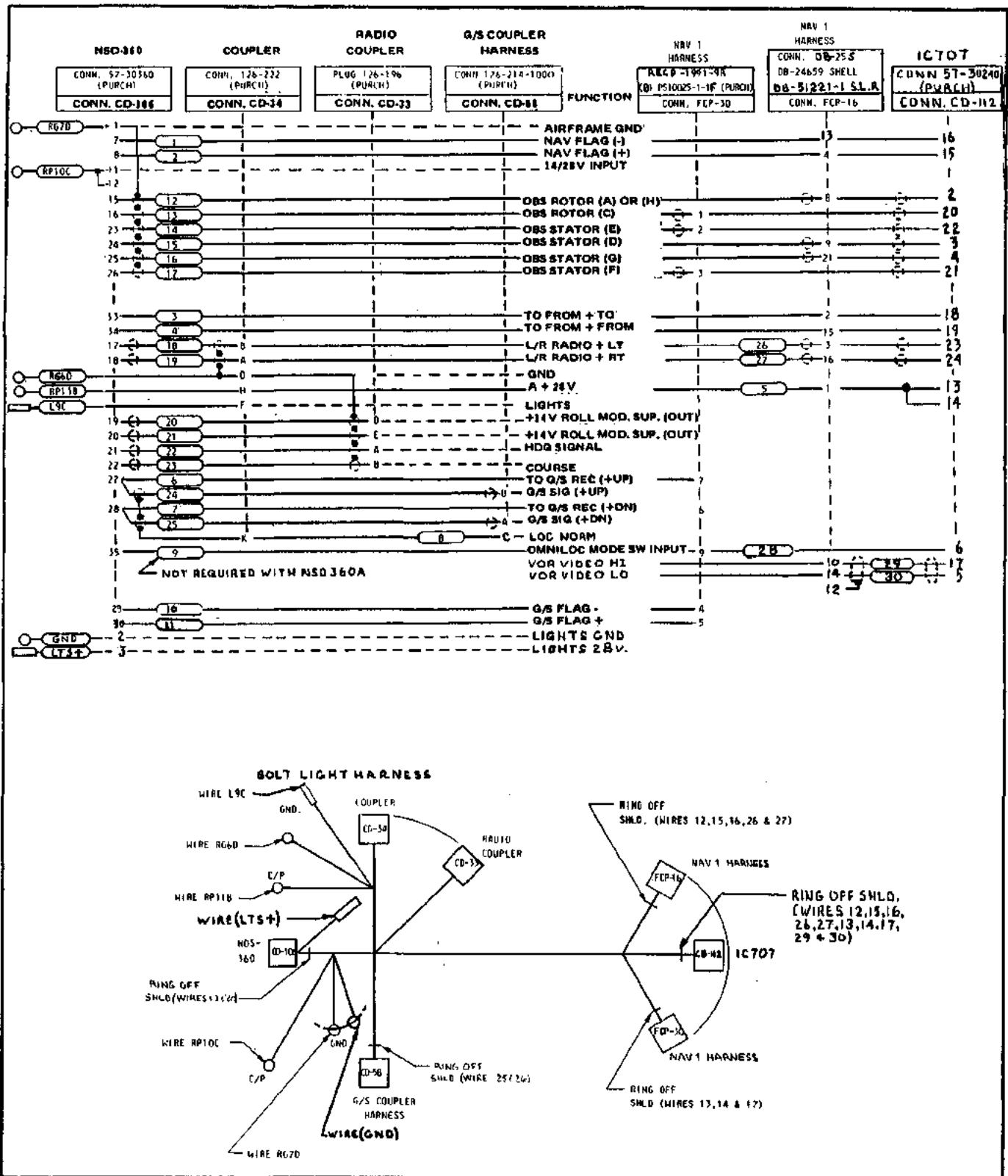

Figure 6-27. HSI, EDO AIRE Mitchell Harness, PA-31-310; -325 and -350

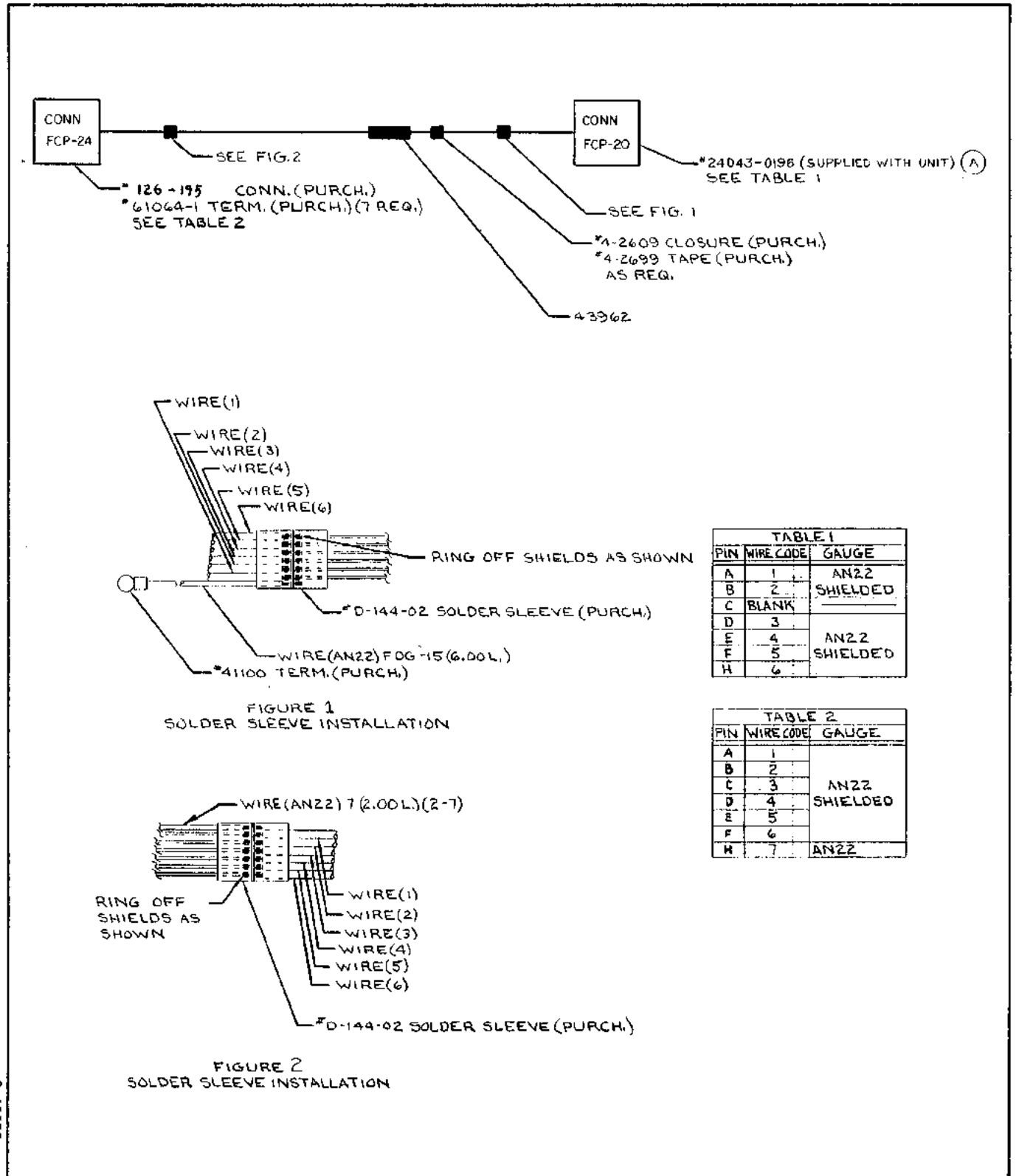

Figure 6-28. Compensator Harness, PA-31-310; -325, -350 and PA-31P

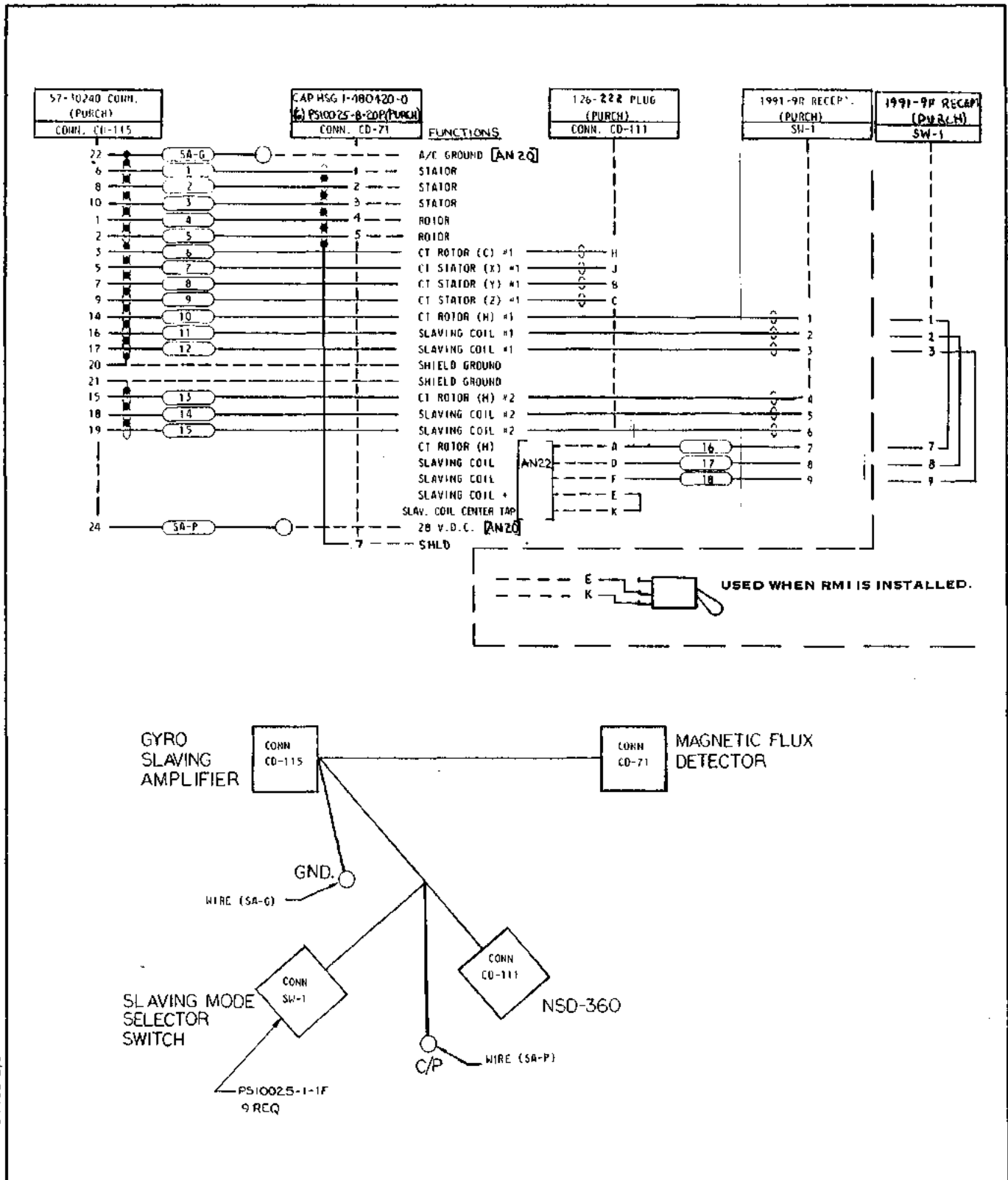

Figure 6-29. Gyro Salving Harness PA-31-310, -325 and -350

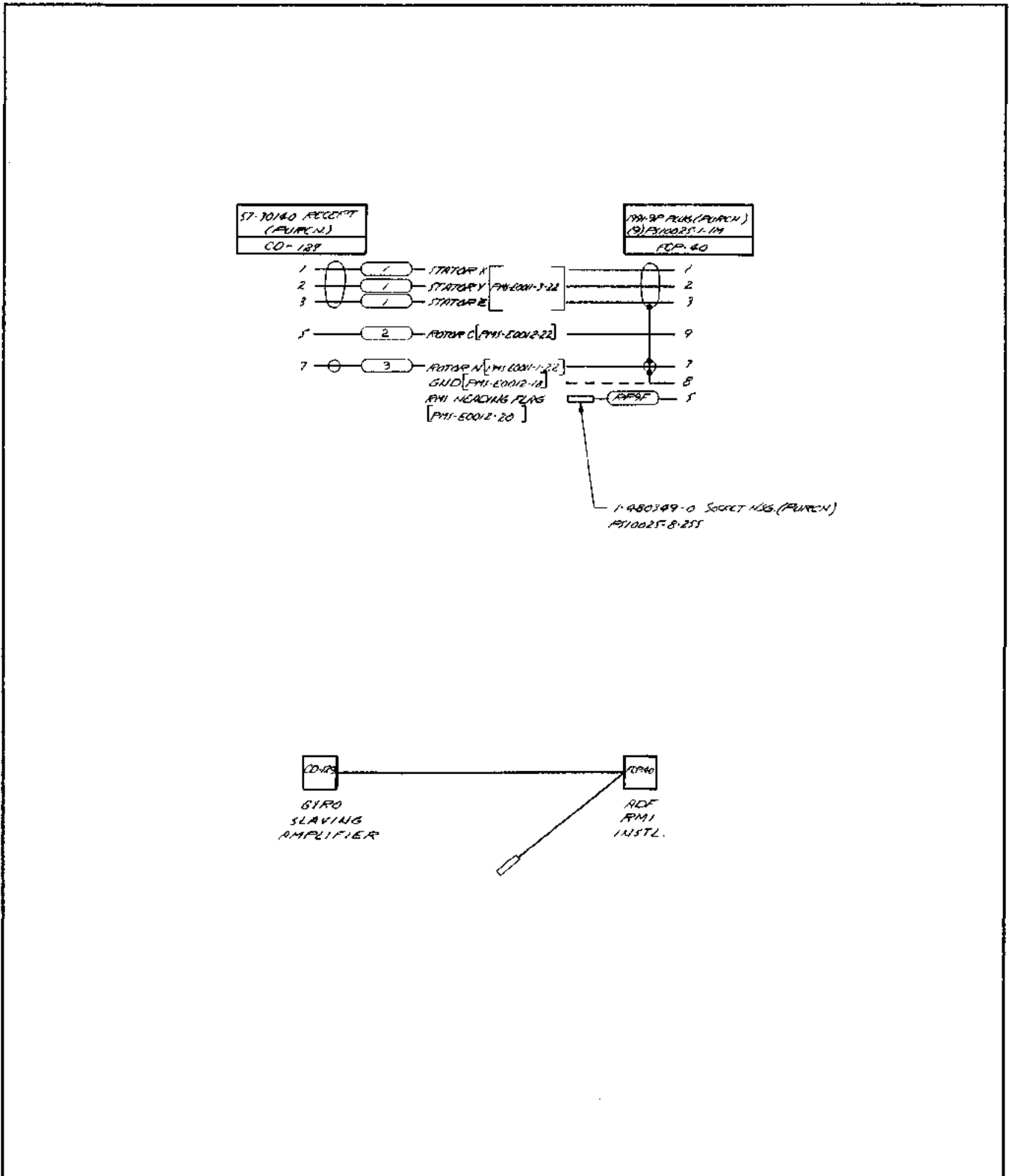

Figure 6-30. Boot Strap Harness, PA-31-310; 325; -350, and PA-31P

48988-2

THIS PAGE INTENTIONALLY LEFT BLANK

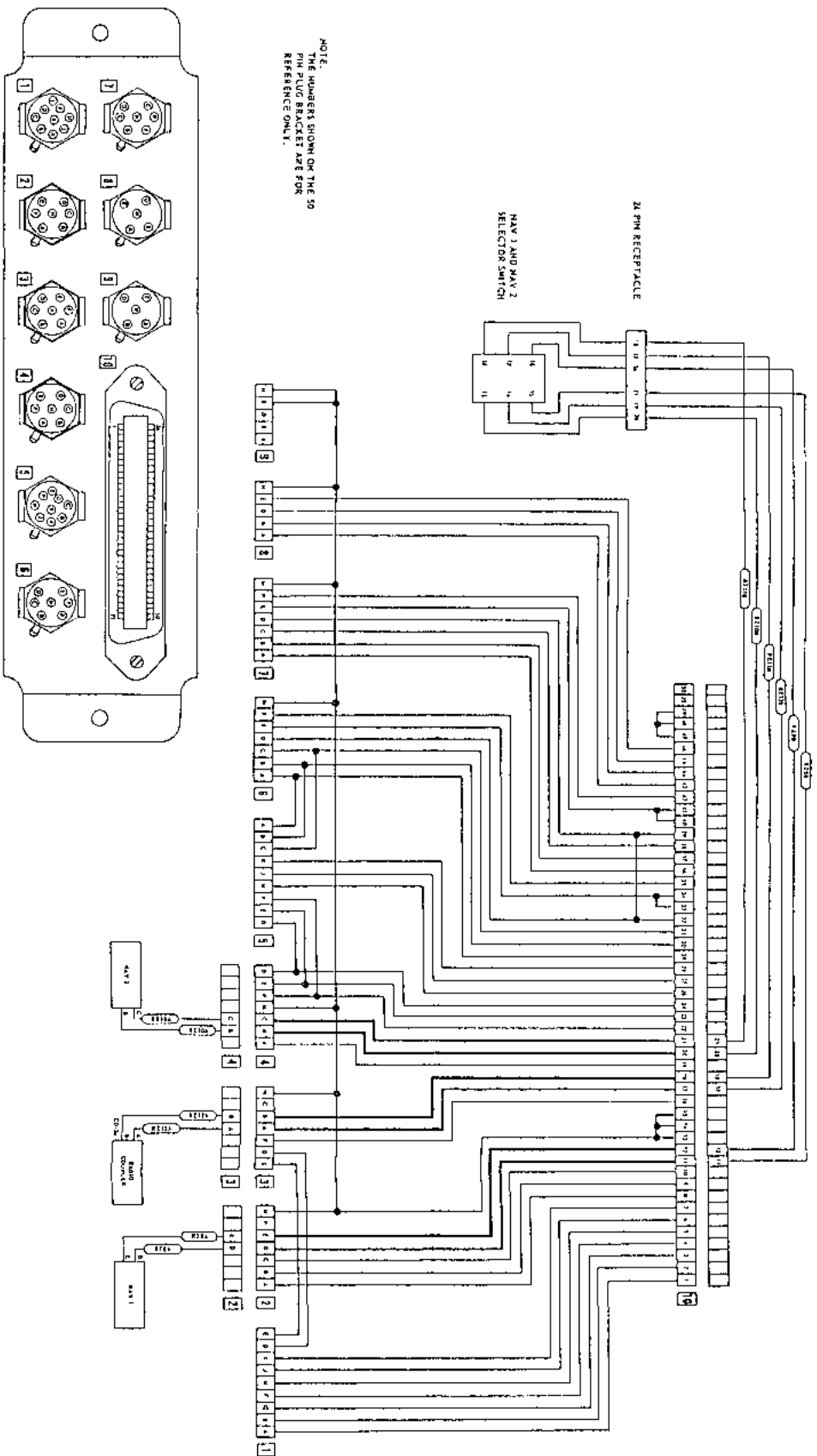

Figure 6-31. Plug Bracket Schematic for Altimatic IIIIC (PA-31)

WIRING DIAGRAMS
REVISED: 4/15/77

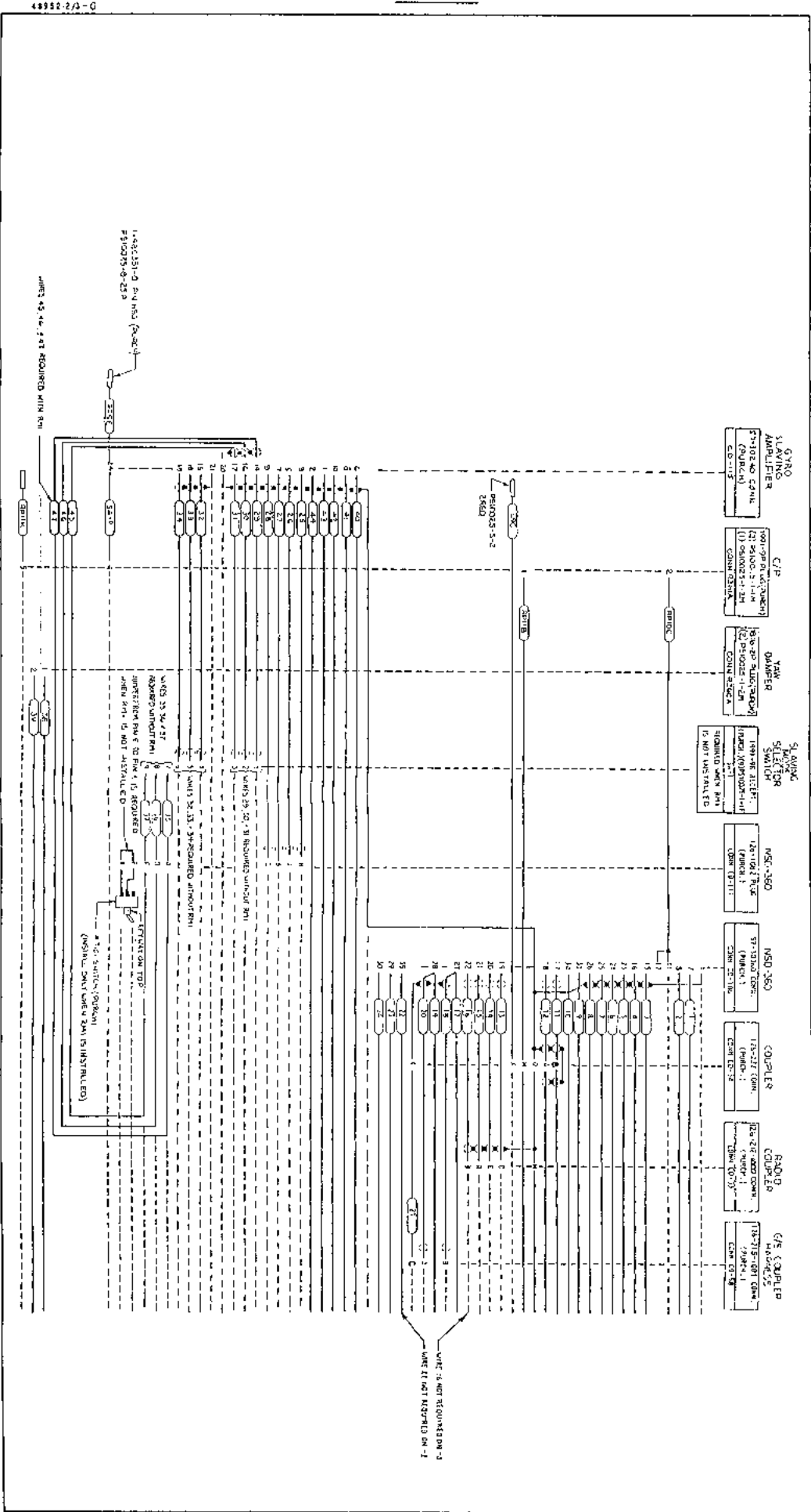

Figure 6-32. HSI, EDO-AIRE Mitchell Harness, PA-31P

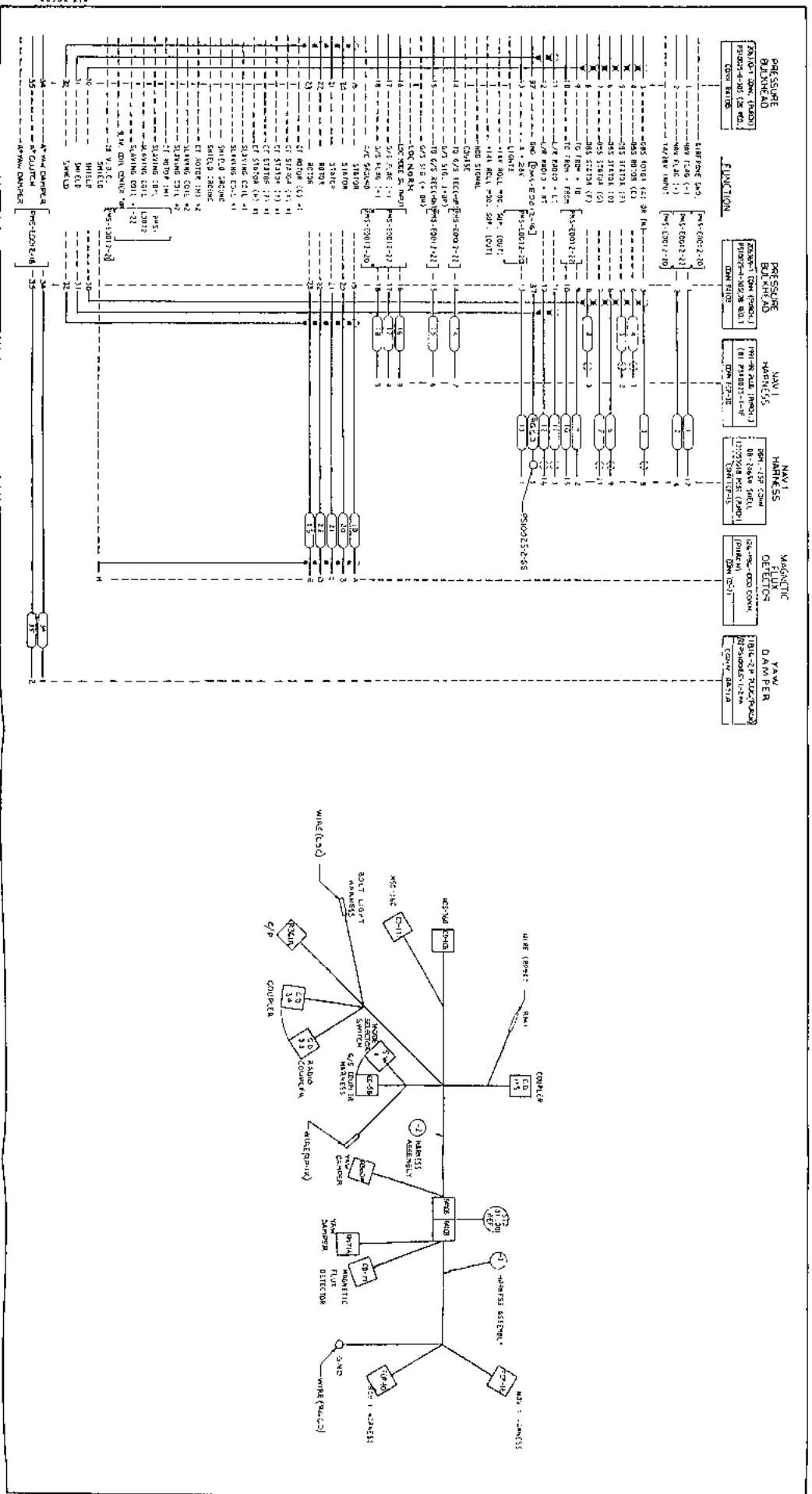

Figure 6-32. HSI, EDO-AIRE Mitchell Harness, PA-31P (cont.)

WIRING DIAGRAMS
REVISED: 3/10/78

PART II

GLIDE SLOPE COUPLER

SECTION VII

DESCRIPTION

Paragraph	Page
7-1. Description	7-1

SECTION VII

DESCRIPTION

7-1. DESCRIPTION. The Glide Slope Coupler is an optional supporting system to the AltiMatic IIC. It is a completely Automatic Analog Computer that directs the Autopilot around the lateral axis to intercept and track the approach glide path. The system automatically provides for variances in glide path angle, wind direction and various approach configurations of the airplane.

When the Glide Slope is properly adjusted and normal approach power is applied, the airplane will accurately follow the glide path. (Refer to Figure 7-1.)

A self contained logic circuit provides for certain conditions to be prevalent before "Lock On" or coupling will occur. This will prevent the Glide Slope from being "Armed" under unfavorable conditions.

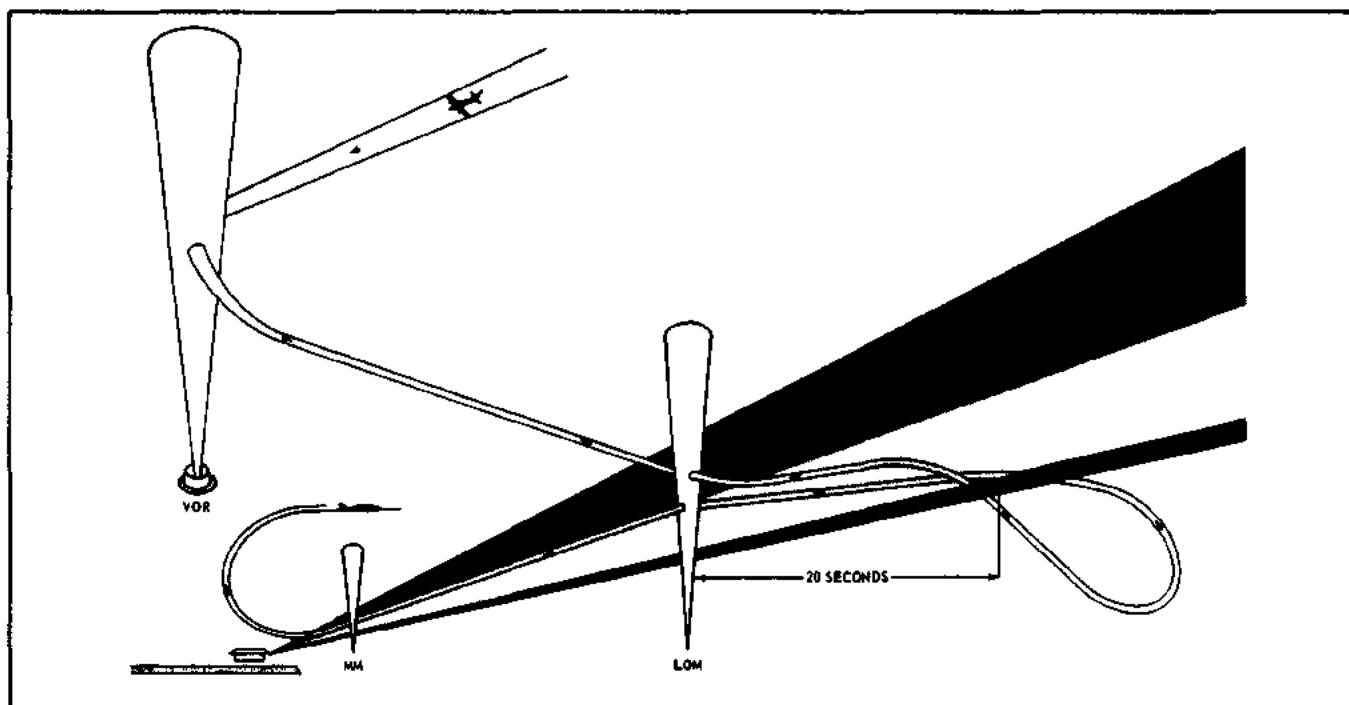

Figure 7-1. AltiMatic IIC Glide Slope Coupler Approach

SECTION VIII
THEORY OF OPERATION

Paragraph	Page
8-1. Theory of Operation	8-1
8-2. Coupling	8-2

SECTION VIII

THEORY OF OPERATION

8-1. THEORY OF OPERATION. The fundamental principle of the Glide Slope Coupler is to couple the Glide Slope to the Autopilot. The Autopilot will then allow the airplane to descend at an angle which corresponds to the Glide Slope to be flown and to introduce a radio deviation signal that will cause descent angle to deviate an amount proportional to the radio signal deviation from the Glide Slope Indicator.

Note in Figure 8-1 that the Glide Slope Coupler is connected in series with the Gyro Horizon and the Altitude Hold. Figure 8-2 shows the Glide Slope Coupler with the complete AltiMatic IIIC system.

Shown in Figure 8-3 is a block diagram of the elements which make up the Glide Slope Coupler. The low level DC signal is derived from the Glide Slope Deviation Indicator and is converted into AC in the low level chopper and then amplified in the AC amplifier. From the amplifier the signal is transformer coupled to a phase detector. This will provide DC isolation from the Glide Slope Indicator. The high level DC voltage out of the phase detector is applied to the integrator circuit. The detector furnishes a signal to a rate network which supplies a DC input to the high level chopper. The high level chopper then receives a signal from the integrator. The AC output of the high level chopper is fed into the output amplifier which is fed in series with the pitch output from the Gyro Horizon.

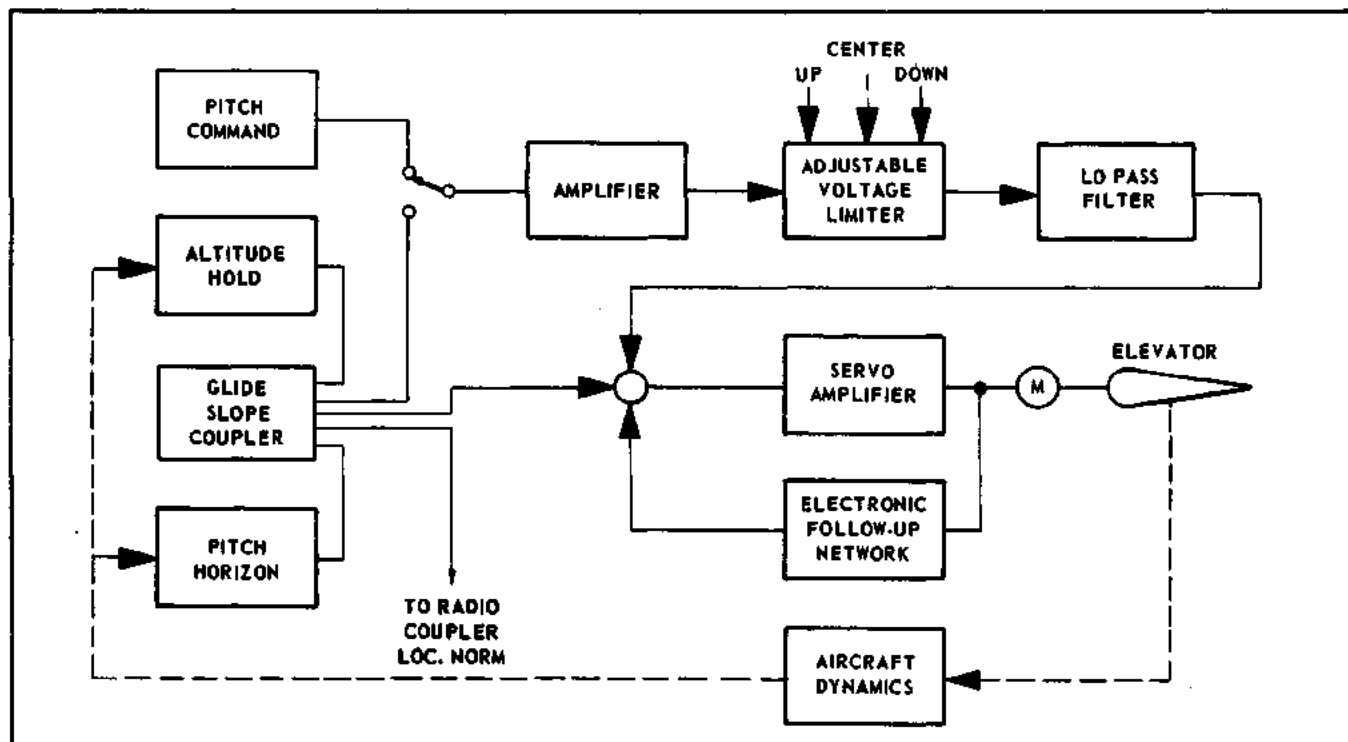

Figure 8-1. Pitch Axis Control System with Glide Slope Coupler

8-2. COUPLING. Coupling or "Arming" will occur ONLY when three conditions have been met, these conditions are:

1. The airplane must be in ALT Hold Mode.
2. The Radio Coupler must be in Localizer Normal Mode.
3. The airplane must be flown under the glide path (at least 60% up indication) for 20 seconds.

The logic circuit, which consists of a bistable multivibrator circuit, insures that all the above conditions prevail prior to arming the coupler. The logic circuit also has a reset function which disarms the circuit if any one of the three inputs are interrupted. After any one of the inputs are interrupted all three conditions must be met again prior to rearming.

Figure 8-2. Block Diagram of AltMatic III with Glide Slope Coupler

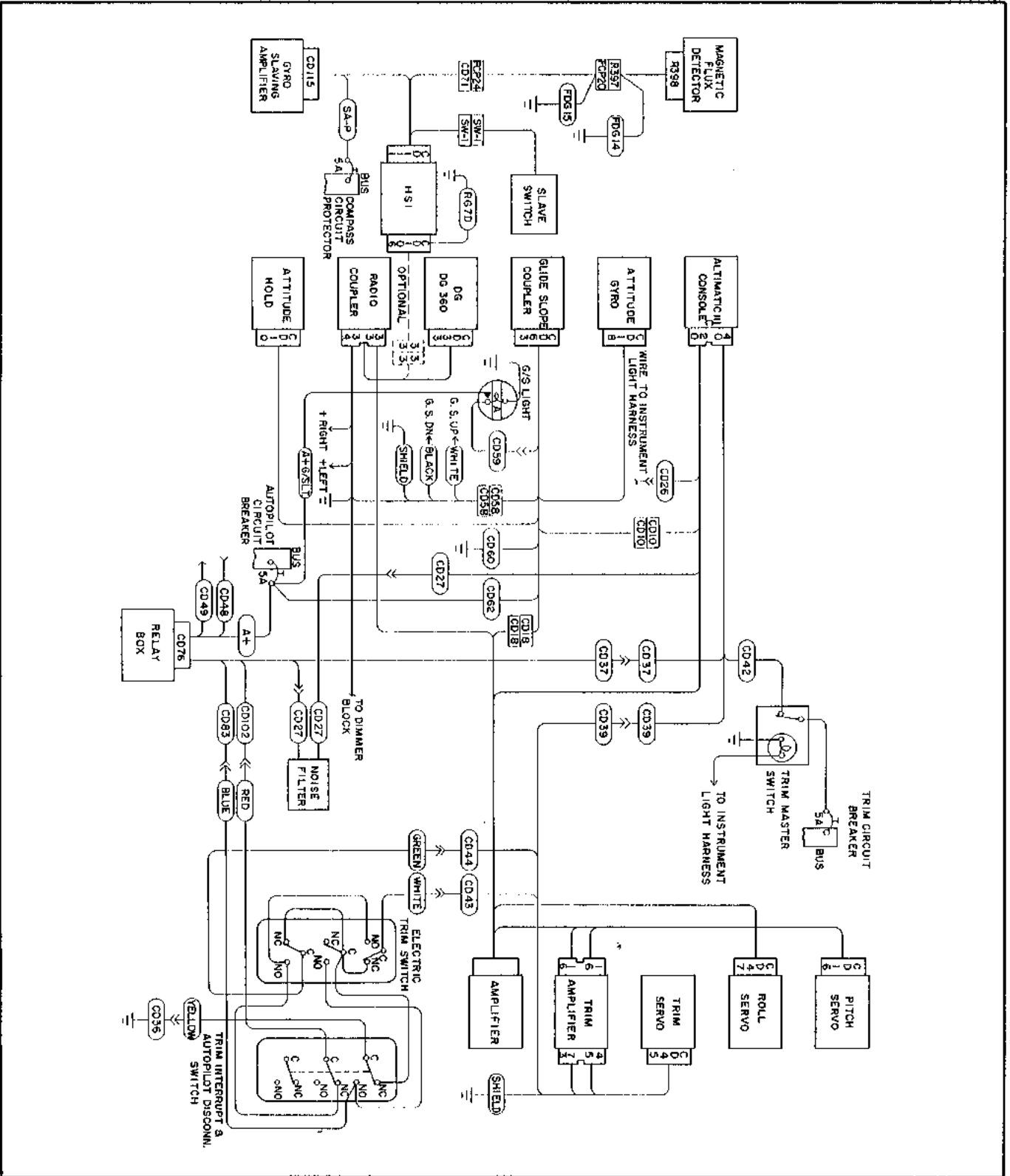

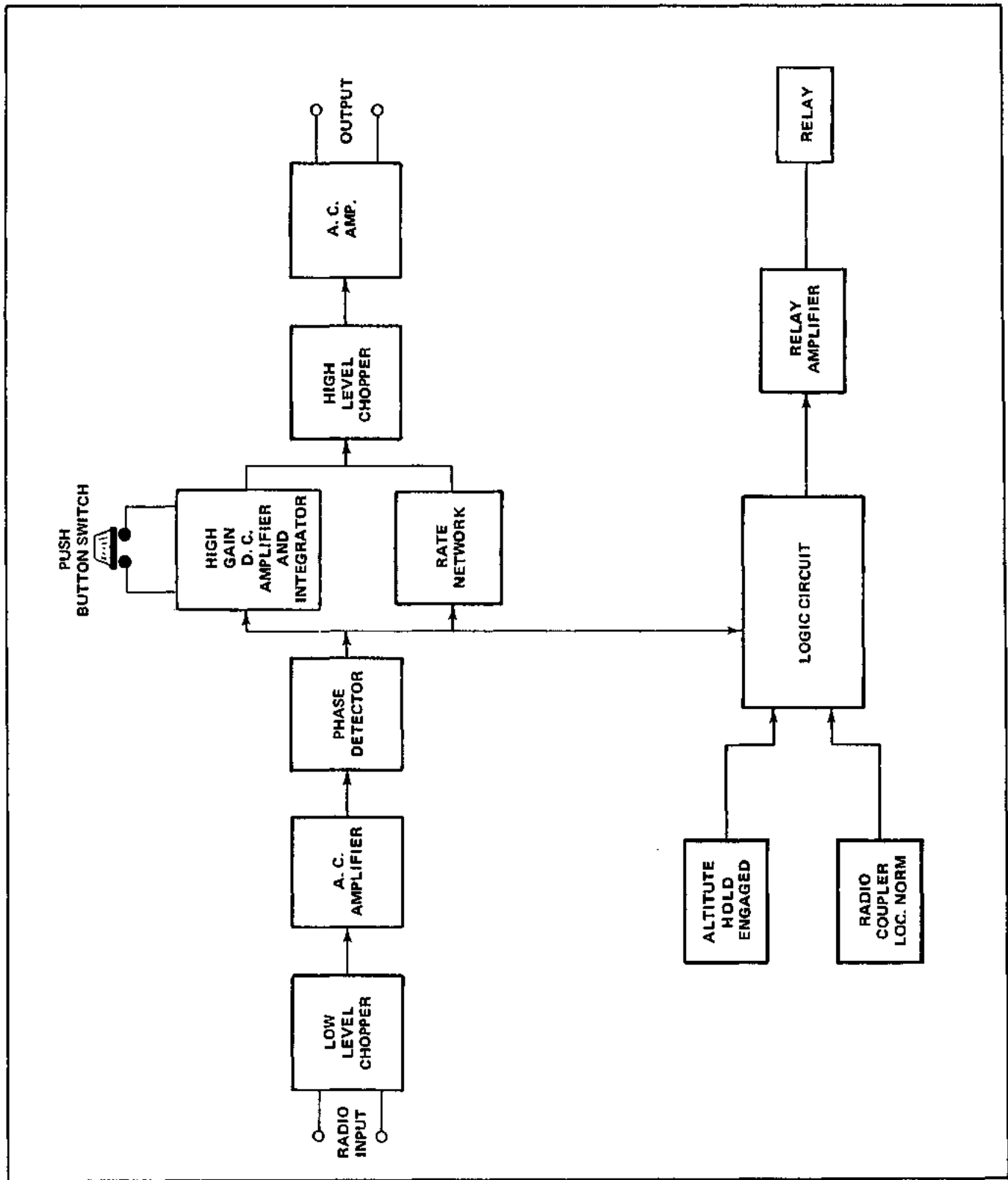

Figure 8-3. Glide Slope Coupler Block Diagram

SECTION IX

REMOVAL AND INSTALLATION

Paragraph	Page
9-1. Introduction	9-1
9-2. Removal of Glide Slope Coupler (PA-23-250 Six Place) E & F Models	9-1
9-3. Installation of Glide Slope Coupler (PA-23-250 Six Place) E & F Models	9-1
9-4. Removal of Glide Slope Coupler (PA-31-310, PA-31-325, PA-31-350 and PA-31P)	9-1
9-5. Installation of Glide Slope Coupler (PA-31-310, PA-31-325, PA-31-350 and PA-31P)	9-1
9-6. Removal of Glide Slope Coupler (PA-32-260, S/N 32-7500001 to 7700023 and PA-32-300, S/N 32-7540001 to 7840045)	9-2
9-7. Installation of Glide Slope Coupler (PA-32-260, S/N 32-7500001 to 7700023 and PA-32-300, S/N 32-7540001 to 7840045)	9-2
9-8. Removal of Glide Slope Coupler (PA-32-260, S/N 32-7800001 and up; PA-32-300, S/N 32-7840046 and up; PA-32R-300, PA-32RT-300, PA-32RT-300T, PA-32-301, PA-32-301T, PA-32R-301, PA-32R-301T and PA-34-200T)	9-2
9-9. Installation of Glide Slope Coupler (PA-32-260, S/N 32-7800001 and up; PA-32-300, S/N 32-7840046 and up; PA-32R-300, PA-32RT-300, PA-32RT-300T PA-32-301, PA-32-301T, PA-32R-301, PA-32R-301T and PA-34-200T)	9-2
➤ 9-10. Removal of Glide Slope Coupler (PA-44-180)	9-3
➤ 9-11. Installation of Glide Slope Coupler (PA-44-180)	9-3
➤ 9-12. Removal of Glide Slope Coupler (PA-28RT-201 and PA-28RT-201T)	9-3
➤ 9-13. Installation of Glide Slope Coupler (PA-28RT-201 and PA-28RT-201T)	9-3

SECTION IX
REMOVAL AND INSTALLATION

9-1. INTRODUCTION. This section covers the removal and installation of the Glide Slope Coupler.

NOTE

For continuous Autopilot use with the Glide Slope Coupler removed, it will be necessary to install a jumper plug, Mitchell P/N 9A88 (Piper P/N 757 325), in the 24-pin CD-63 receptacle of the Glide Slope Cable Harness.

9-2. REMOVAL OF GLIDE SLOPE COUPLER. (PA-23-250 Six Place) E & F Model's.

The Glide Slope Coupler is located under the instrument panel on the right side of the fuselage and is attached to the fuselage frame.

- a. Remove the Glide Slope Coupler from the mounting brackets by removing the screws and nuts which secure the mounting brackets.
- b. Release the spring clips on the CD-63 connector. Disconnect CD-63 from the Glide Slope Coupler.
- c. If the airplane will be flown prior to reinstallation of the Glide Slope Coupler install jumper plug, Mitchell P/N 9A88 (Piper P/N 757 325), in the CD-63 harness connector.

9-3. INSTALLATION OF GLIDE SLOPE COUPLER. (PA-23-250 Six Place) E & F Model's. (Refer to Figure 9-1.)

- a. If the jumper plug, Mitchell P/N 9A88 (Piper P/N 757 325), has been installed in the Glide Slope Harness connector CD-63, remove it.
- b. Connect CD-63 24-pin connector and make sure the spring clips are snapped in place.
- c. Place the Glide Slope on the mounting brackets on the fuselage frame. Position it so the end with the CD-63 receptacle is aft.
- d. Secure it with the screws and nuts previously removed.

9-4. REMOVAL OF GLIDE SLOPE COUPLER. (PA-31-310, PA-31-325, PA-31-350 and PA-31P)

(PA-31 only.) The Glide Slope Coupler is located under the right side of the instrument panel. (PA-31P only.) The Glide Slope Coupler is located under the center of the instrument panel to the rear of the pedestal.

- a. (PA-31P only.) Remove the screws securing the center instrument panel and move panel slightly aft to gain access to Glide Slope Coupler.
- b. Release the spring clips on CD-63 connector. Disconnect CD-63 from the Glide Slope Coupler.
- c. If the airplane will be flown prior to reinstallation of the Glide Slope Coupler, install jumper plug, Mitchell P/N 9A88 (Piper P/N 757 325), in the CD-63 connector.
- d. Remove the two screws which secure the Glide Slope Coupler to the mounting bracket.
- e. (PA-31P only.) Remove the two screws which secure the Glide Slope mounting bracket to the instrument panel and remove coupler and mounting bracket.

9-5. INSTALLATION OF GLIDE SLOPE COUPLER. (PA-31-310, PA-31-325, PA-31-350 and PA-31P) (Refer to Figure 9-2 or Figure 9-3.)

- a. (PA-31P only.) Place the Glide Slope Coupler with mounting bracket under the center of the instrument panel. Position it so the 24-pin receptacle is to the left of the pedestal.
- b. Place the Glide Slope Coupler on the mounting bracket under the right side of the instrument panel. Position it so the 24-pin receptacle is on top of the Glide Slope Coupler.

- c. (PA-31P only.) Secure the Coupler with mounting bracket to the instrument panel with two screws.
- d. Secure the Coupler to the mounting bracket with two screws.
- e. If the jumper plug has been installed in the Glide Slope Harness connector CD-63, remove it.
- f. Connect the CD-63, 24-pin connector and make sure the spring clips are snapped in place.

9.6. REMOVAL OF GLIDESLOPE COUPLER. (PA-32-260, S/N 32-7500001 to 7700023 and PA-32-300, S/N 32-7540001 to 7840045)

The Glide Slope Coupler is located beneath the instrument panel and is attached to the forward side of the glove box.

- a. Release the spring clips on CD-63 connector and disconnect the CD-63 connector from the Glide Slope Coupler.
- b. Remove the screws and nuts which secure the Glide Slope Coupler to the brake channel and remove coupler.
- c. If the airplane will be flown prior to reinstallation of the Glide Slope Coupler, install jumper plug, Mitchell P/N 9A88 (Piper P/N 757 325), in the CD-63 harness connector.

9-7. INSTALLATION OF GLIDE SLOPE COUPLER. (PA-32-260, S/N 32-7500001 to 7700023 and PA-32-300, S/N 32-7540001 to 7840045) (Refer to Figure 9-4.)

- a. If the jumper plug, Mitchell P/N 9A88 (Piper P/N 757 325), has been installed in the Glide Slope Coupler Harness Connector CD-63, remove it.
- b. Place the Glide Slope Coupler on the forward side of the glove box with the CD-63 connector pointing inboard.
- c. Ascertain the ground wire CD-60 from the CD-63 connector harness is located under the screw on the glove box.
- d. Secure the Glide Slope Coupler to the glove box with the appropriate screws and nuts.
- e. Connect the CD-63 24-pin connector to the coupler and make sure the spring clips are snapped in place.

9-8. REMOVAL OF GLIDE SLOPE COUPLER. (PA-32-260, S/N 32-7800001 and up; PA-32-300, S/N 32-7840046 and up; PA-32R-300, PA-32RT-300, PA-32RT-300T, PA-32-301, PA-32-301T, PA-32R-301, PA-32R-301 and PA-34-200T)

The Glide Slope Coupler is located beneath the instrument panel and is attached to the forward left side of the brake channel.

- a. Release the spring clips on CD-63 connector and disconnect the CD-63 connector from the Glide Slope Coupler.
- b. Remove the screws and nuts which secure the Glide Slope Coupler to the brake channel and remove coupler.
- c. If the airplane will be flown prior to reinstallation of the Glide Slope Coupler, install jumper plug, Mitchell P/N 9A88 (Piper P/N 757 325), in the CD-63 harness connector.

9-9. INSTALLATION OF GLIDE SLOPE COUPLER. (PA-32-260, S/N 32-7800001 and up; PA-32-300, S/N 32-7840046 and up; PA-32R-300, PA-32RT-300, PA-32RT-300T, PA-32-301, PA-32-301T, PA-32R-301, PA-32R-301T and PA-34-200T) (Refer to Figure 9-5.)

- a. If the jumper plug, Mitchell P/N 9A88 (Piper P/N 757 325), has been installed in the Glide Slope Coupler Harness connector CD-63, remove it.
- b. Place the Glide Slope Coupler on the left side of the brake channel with the CD-63 receptacle of the coupler pointing forward.
- c. Ascertain the ground wire CD-60 from the CD-63 connector harness is placed under the forward mounting screw of the coupler.
- d. Secure the Glide Slope Coupler to the brake channel with the appropriate screws and nuts.
- e. Connect the CD-63 24-pin connector to the coupler and make sure the spring clips are snapped in place.

9-10. REMOVAL OF GLIDE SLOPE COUPLER. (PA-44-180)

The Glide Slope Coupler is located on the forward side of the bulkhead at STA. 47.65 on the left side of the airplane.

- a. Release the latches on the nose cone and swing it down out of the way to gain access to the Glide Slope Coupler.
- b. Release the spring clips on CD-63 connector and disconnect the CD-63 connector from the Glide Slope Coupler.
- c. Remove the screws and nuts which secure the Glide Slope Coupler to the bulkhead and remove coupler.
- d. If the airplane will be flown prior to reinstallation of the Glide Slope Coupler, install jumper plug, Mitchell P/N 9A88 (Piper P/N 757 325), in the CD-63 harness connector.

9-11. INSTALLATION OF GLIDE SLOPE COUPLER. (PA-44-180) (Refer to Figure 9-6.)

- a. If jumper plug, Mitchell P/N 9A88 (Piper P/N 757 325), has been installed in the Glide Slope Coupler Harness connector CD-63, remove it.
- b. Place the Glide Slope Coupler on the forward side of the bulkhead at STA. 47.65 on the left side of the airplane with the CD-63 connector pointing inboard.
- c. Ascertain the ground wire CD-60 from the CD-63 connector harness is placed under the upper inboard mounting screw of the coupler.
- d. Secure coupler to bulkhead with screws and nuts previously removed.
- e. Connect the CD-63 24-pin connector to the coupler and make sure the spring clips are snapped in place.

➔ **9-12. REMOVAL OF GLIDE SLOPE COUPLER. (PA-28RT-201 and PA-28RT-201T)**

The Glide Slope Coupler is located under the instrument panel on the right side of the fuselage.

- a. Release the spring clips on CD-63 connector and disconnect the CD-63 connector from the Glide Slope Coupler.
- b. Remove the screws and nuts which secure the Glide Slope Coupler to the brake channel and remove coupler.
- c. If the airplane will be flown prior to reinstallation of the Glide Slope Coupler, install jumper plug, Mitchell P/N 9A88 (Piper P/N 757 325), in the CD-63 harness connector.

➔ **9-13. INSTALLATION OF GLIDE SLOPE COUPLER (PA-28RT-201 and PA-28RT-201T) (Refer to Figure 9-8.)**

- a. If the jumper plug, Mitchell P/N 9A88 (Piper P/N 757 325), has been installed in the Glide Slope Coupler Harness connector CD-63, remove it.
- b. Place the Glide Slope Coupler on the mounting bracket under the right side of the instrument panel with the CD-63 connector pointing up.
- c. Ascertain the ground wire CD-60 from the CD-63 connector harness is placed under the upper rear mounting screw of the coupler.
- d. Secure the Glide Slope Coupler to the glove box with the appropriate screws and nuts.
- e. Connect the CD-63 24-pin connector to the coupler and make sure the spring clips are snapped in place.

**THIS PAGE
INTENTIONALLY LEFT BLANK**

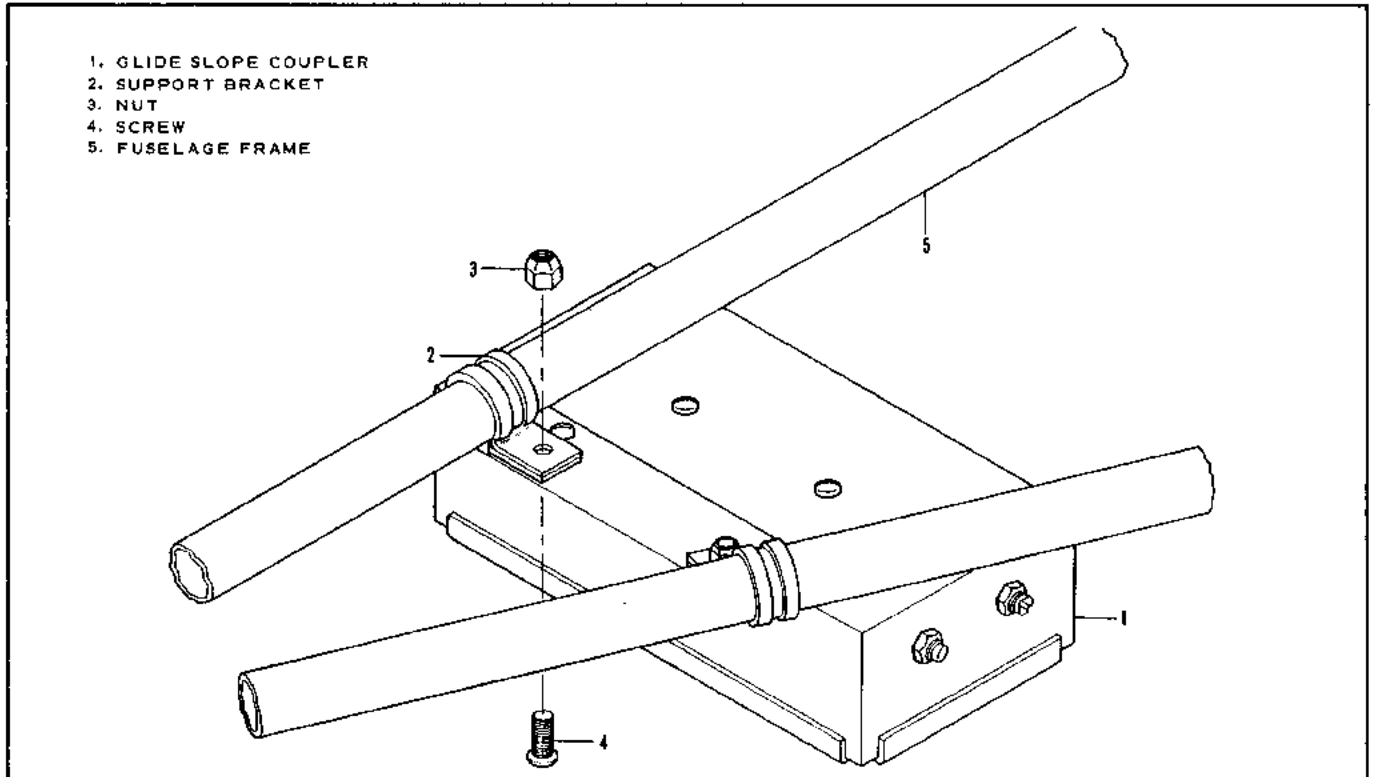

Figure 9-1. Glide Slope Coupler Installation, PA-23-250 (Six Place) E & F Model's

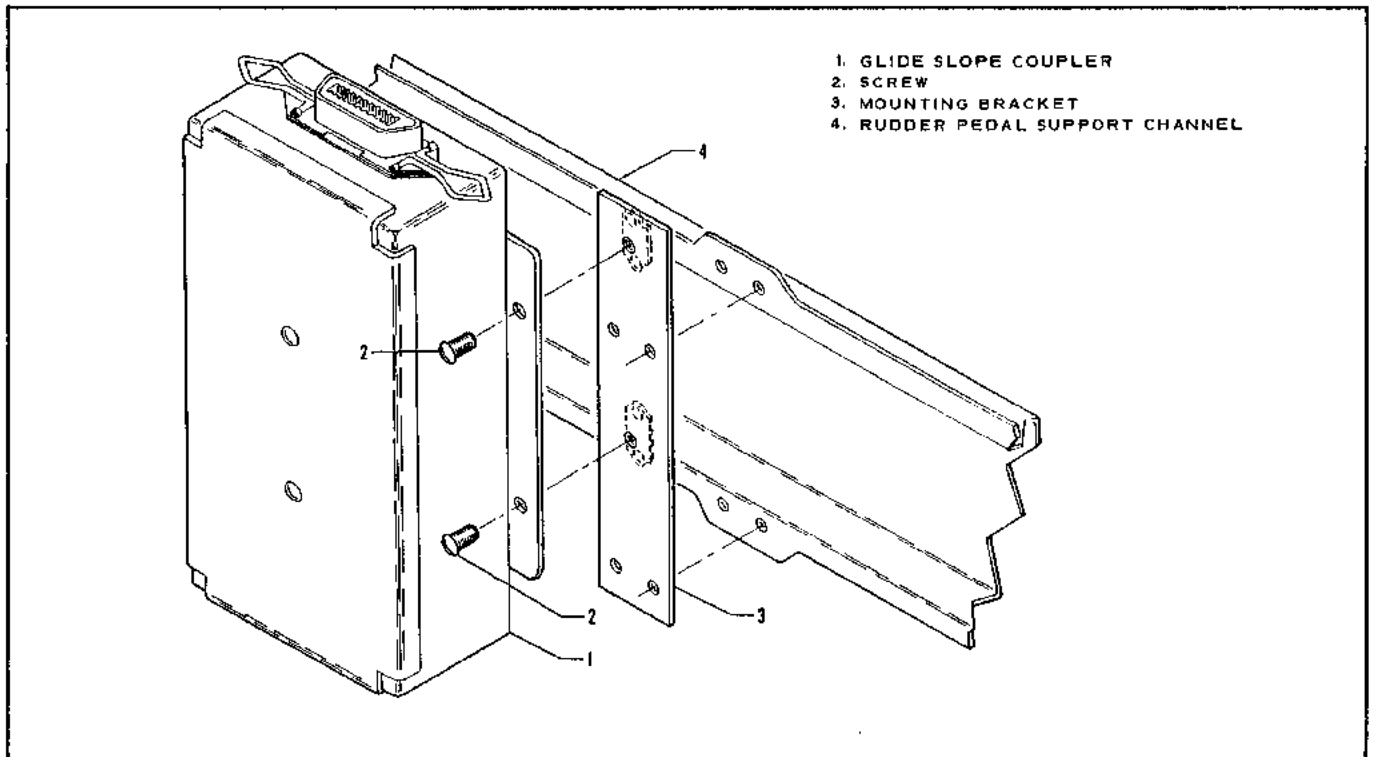

Figure 9-2. Glide Slope Coupler Installation, PA-31-310, PA-31-325 and PA-31-350

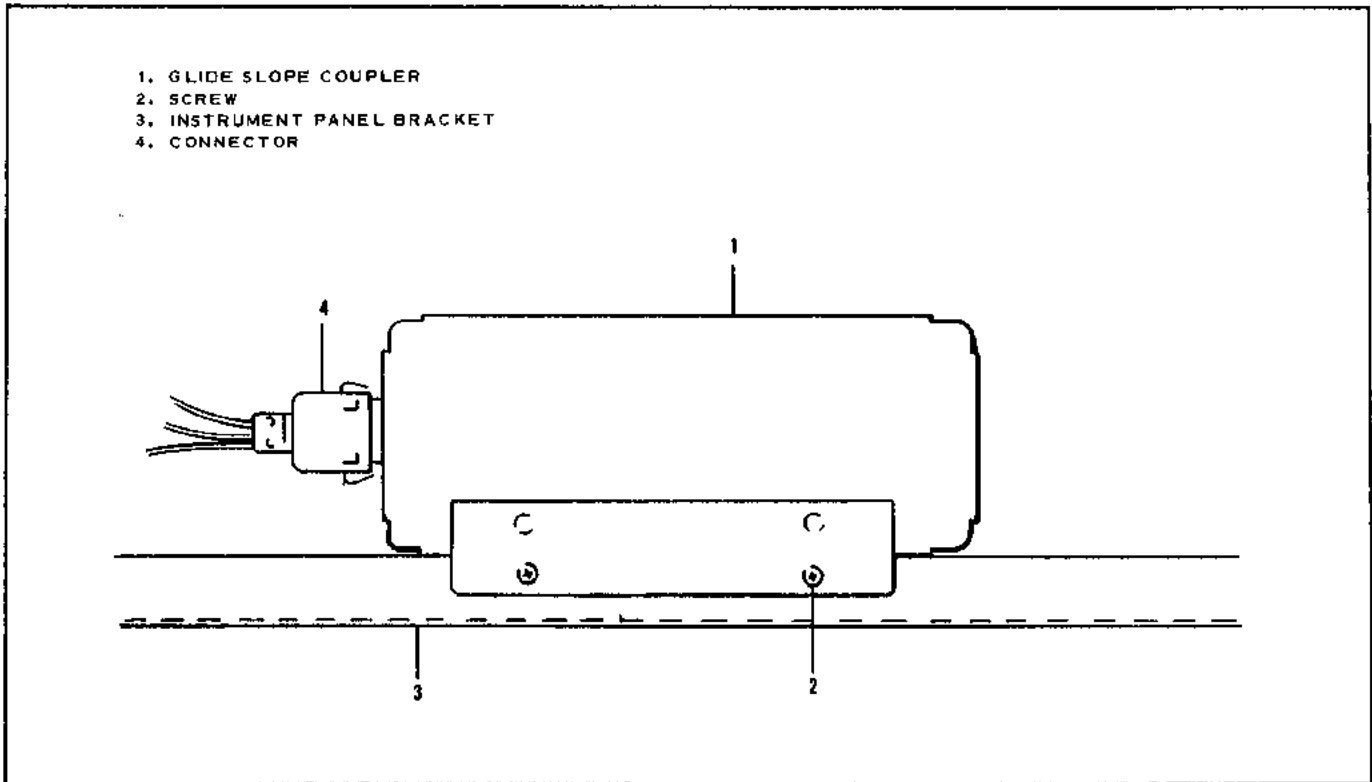

Figure 9-3. Glide Slope Coupler Installation, PA-31P

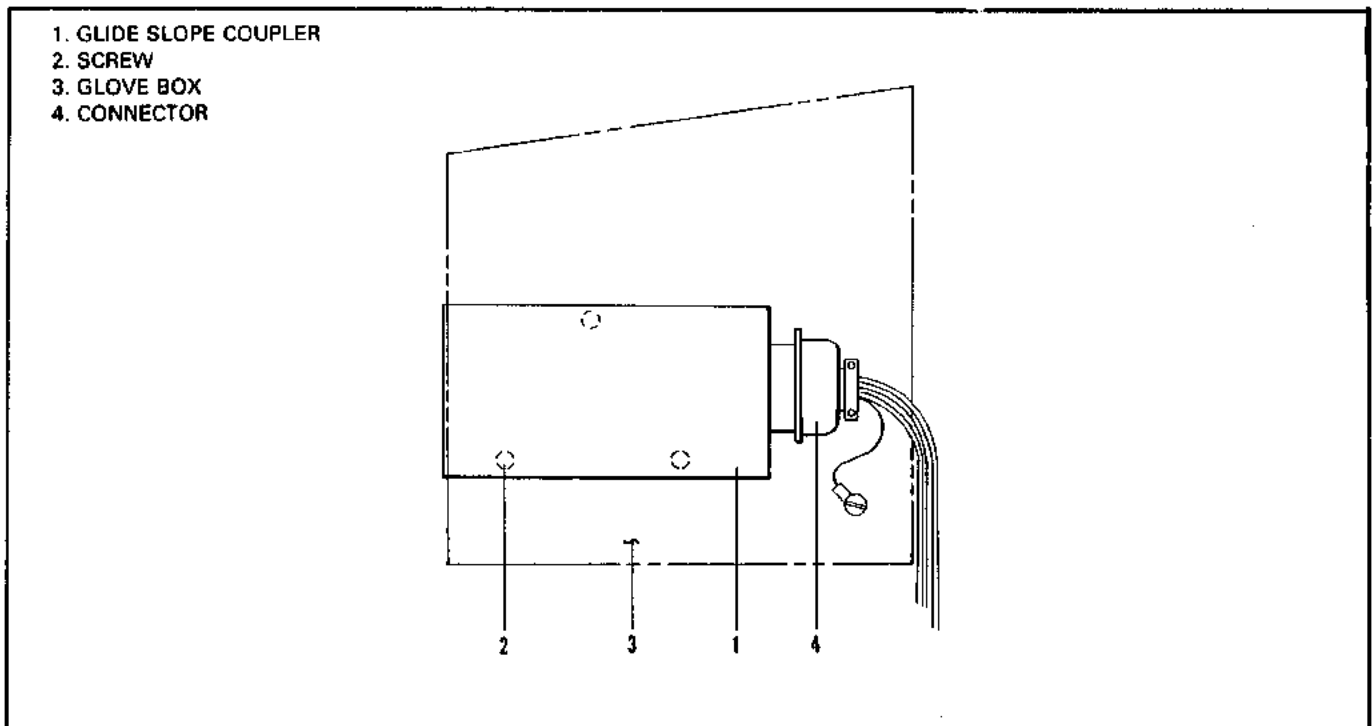

Figure 9-4. Glide Slope Coupler Installation, PA-32-260, S/N 32-750001 to 7700023
and PA-32-300, S/N 32-7540001 to 7840045

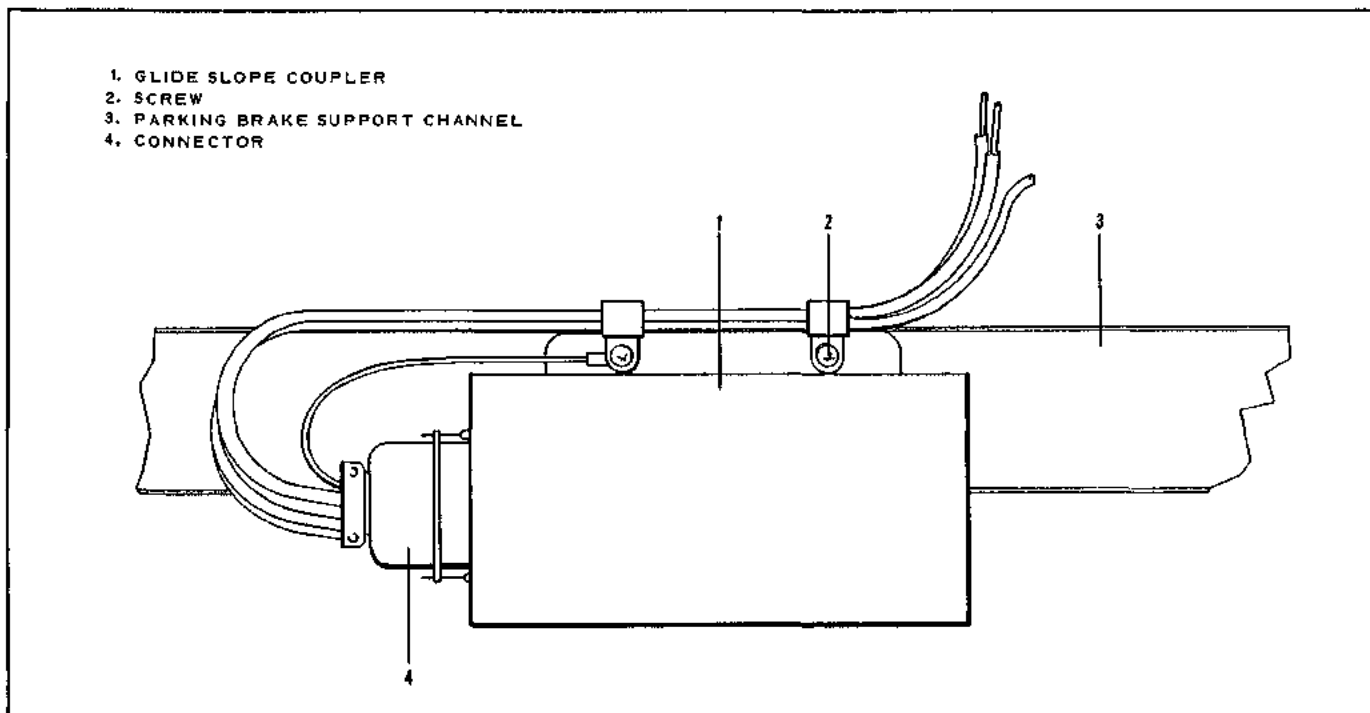

Figure 9-5. Glide Slope Coupler Installation, PA-32-260, S/N 32-7800001 and up; PA-32-300, S/N 32-7840046 and up; PA-32R-300, PA-32RT-300, PA-32RT-300T, PA-32-301, PA-32-301T, PA-32R-301, PA-32R-301T and PA-34-200T

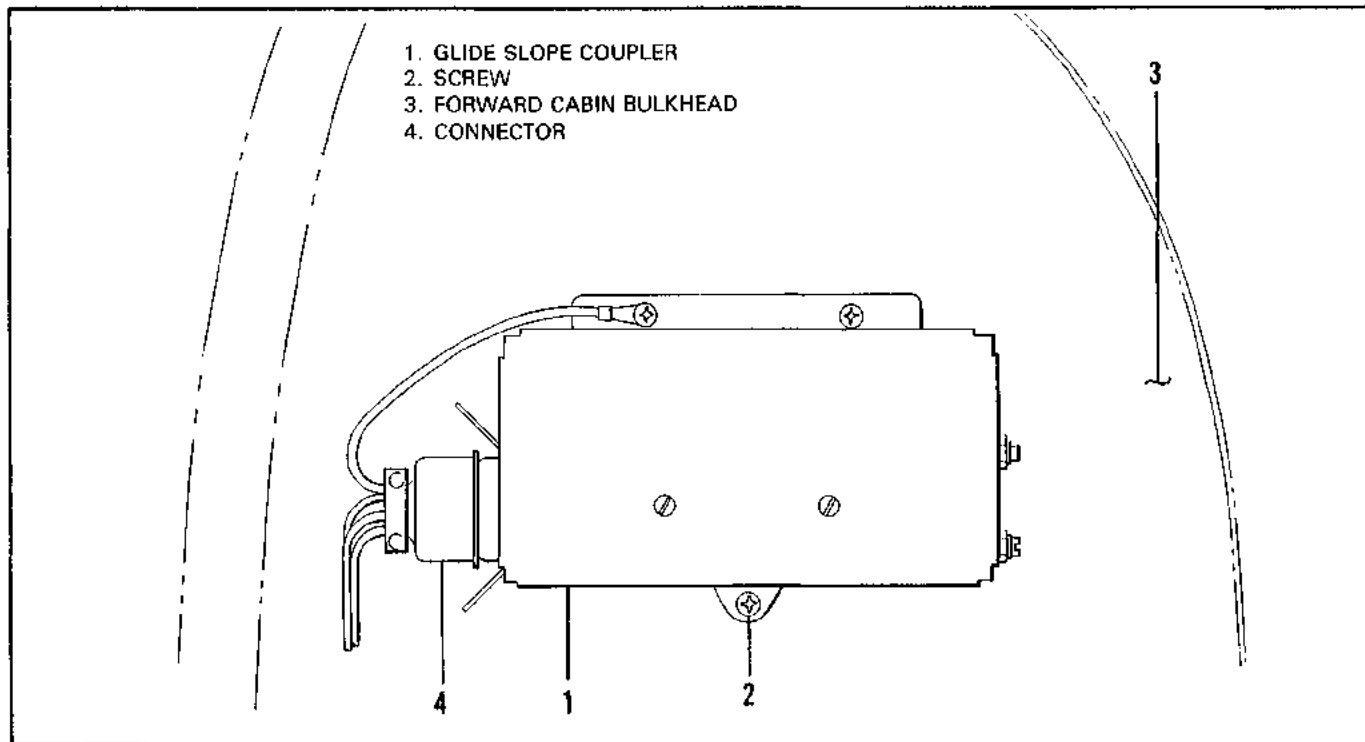

Figure 9-6. Glide Slope Coupler Installation, PA-44-180

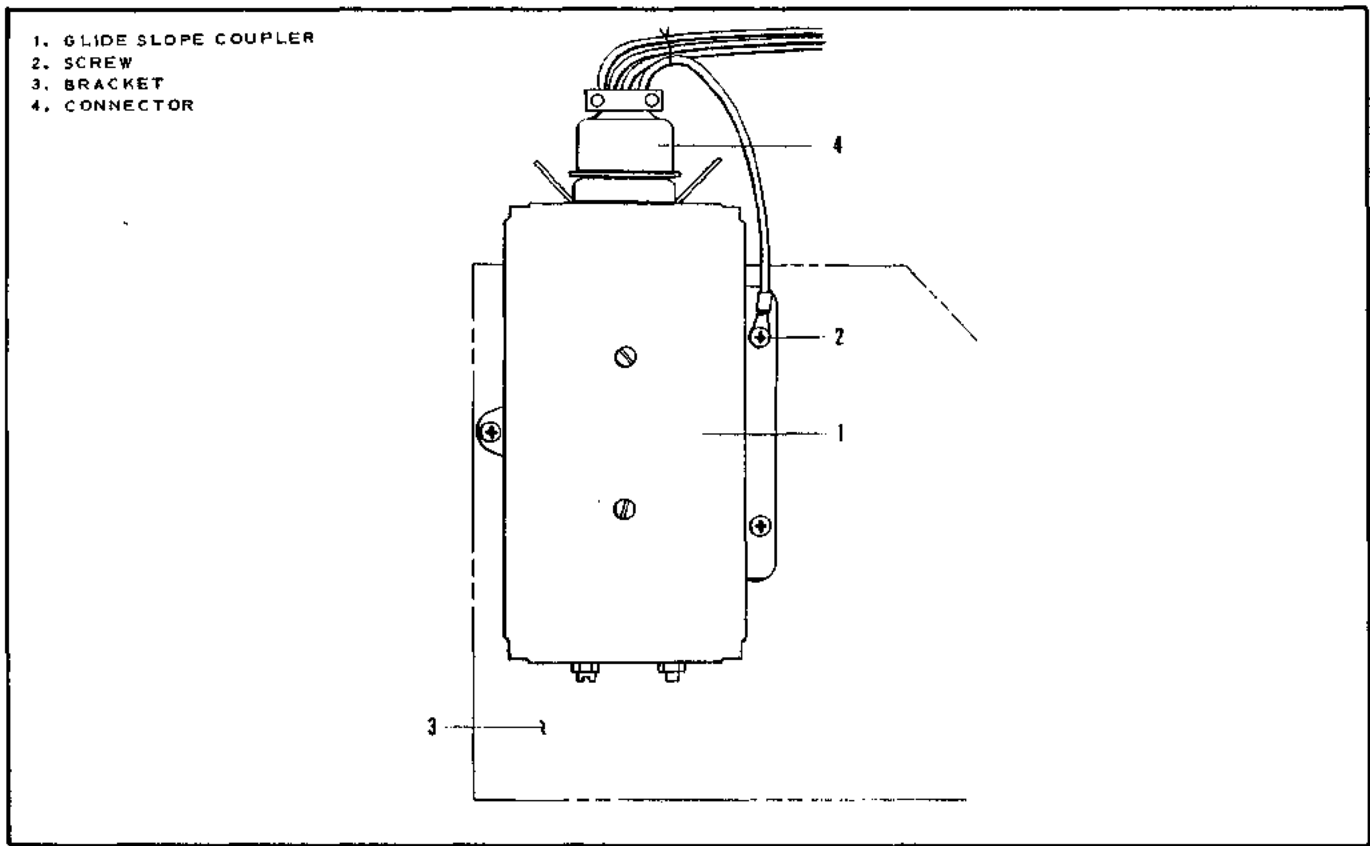

Figure 9-7. Glide Slope Coupler Installation, PA-28RT-201 and PA-28RT-201T

SECTION X
TEST EQUIPMENT

Paragraph	Page
10-1. Test Equipment Requirements	10-1
10-2. 66D141-4 Radio Coupler Tester	10-1
10-3. Glide Slope Cables	10-1
10-4. Troubleshooting	10-1

SECTION X
TEST EQUIPMENT

10-1. TEST EQUIPMENT REQUIREMENTS. Autopilot Test Kit Piper P/N 753 439 (66D141). In addition to this test equipment, there are several additional cables which will be required.

The use of the 66D141-1, 66D141-2 and 66D141-3 is not explained because they are used the same as described in Section IV of this manual. The 66D141-4 Radio Coupler Tester is used differently. This is explained in Paragraph 10-2.

10-2. 66D141-4 RADIO COUPLER TESTER. The Radio Coupler Tester contains a simulated radio signal source to provide Glide Slope Signal Deviation thus allowing the system to be static tested. The Radio Coupler Test Box will perform the following functions:

- a. The Lower Radio Signal Meter simulates a Glide Slope Deviation Indicator. Blue represents UP and yellow represents DOWN.
- b. The Radio Signal Substitute Knob, located to the right of the Lower Omni Meter, when pulled out "ON" and rotated will give either a fly "UP" or "DOWN" signal.
- c. The 9-pin CD-34 connector connects to Test Cable 30A300 to provide simulated Glide Slope information to the Glide Slope Coupler.

10-3. GLIDE SLOPE CABLES. Given in this paragraph are the additional items which are used for testing the Glide Slope Coupler. (Refer to Figure 10-1.)

- a. Glide Slope Coupler Light Cable, Mitchell P/N 30B317 (Piper P/N 757 873).
- b. Glide Slope Coupler Test Cable, Mitchell P/N 30A300 (Piper P/N 757 874).
- c. Glide Slope Coupler Cable, Mitchell P/N 30C291 (Piper P/N 752 010). This is the same cable used for installation in the airplane and is not shown in Figure 10-1.
- d. Glide Slope Coupler Extension Cable, Mitchell P/N 30C267 (Piper P/N 757 875). Used for flight adjustment.
- e. Jumper Plug, Mitchell P/N 9A88 (Piper P/N 757 325). This is not used for testing. It is installed in the airplane Glide Slope Harness while the Glide Slope Coupler is removed.

10-4. TROUBLESHOOTING.

- a. It is recommended that the technician determine the nature and specific area of trouble as accurately as possible by questioning the pilot.
- b. Refer to Table X-I before attempting to troubleshoot the system. Isolate the trouble into one group.
 1. The first group concerns the inputs to the Glide Slope Coupler. It is recommended that the technician, by use of the appropriate test equipment, reproduce the input signals and observe that the output, in this case, the Autopilot, responds either correctly or incorrectly. The reason is that this group is the easiest to work on.

TABLE X-I. TROUBLE ISOLATION BLOCK DIAGRAM

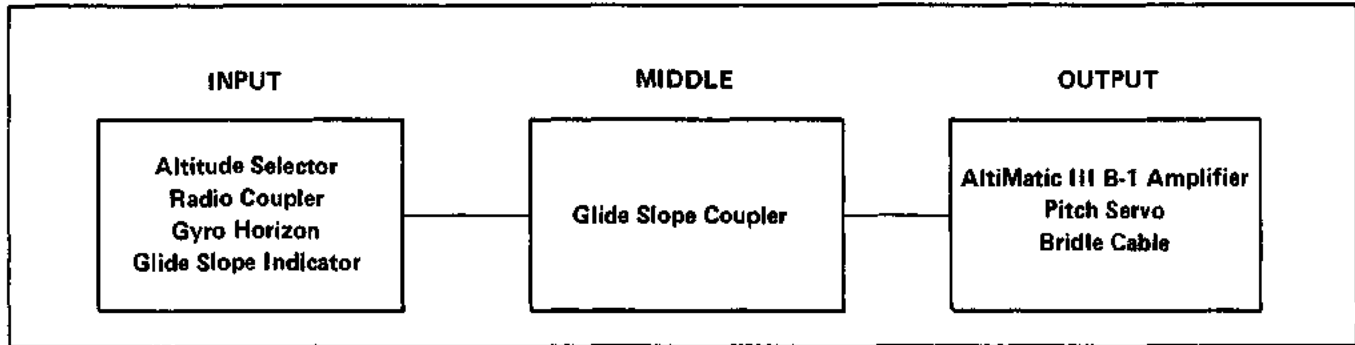

2. If, with the correct inputs, the Autopilot does not respond correctly, the middle group (in this case the Glide Slope Coupler) should be removed and bench checked in accordance with Section XI.

3. If the inputs are correct and the middle section (Glide Slope Coupler) performs satisfactorily on the bench check, the output group should be checked. Since the output group is the pitch portion of the AltiMatic Autopilot, it is recommended that it be checked out in accordance with Section V of this manual.

c. Since the Glide Slope Coupler signal is an additional input to the pitch portion of the AltiMatic Autopilot it is essential that it be established as to whether or not the problem is peculiar to the Glide Slope Coupler operation, an example: Complaint, aircraft "porpoises while making ILS approach." This problem could be caused by malfunctions other than the Glide Slope Coupler such as AltiMatic Amplifier, loose control or bridle cable and faulty electric trim. At this point it would be wise to check out the AltiMatic pitch system without the Glide Slope Coupler engaged.

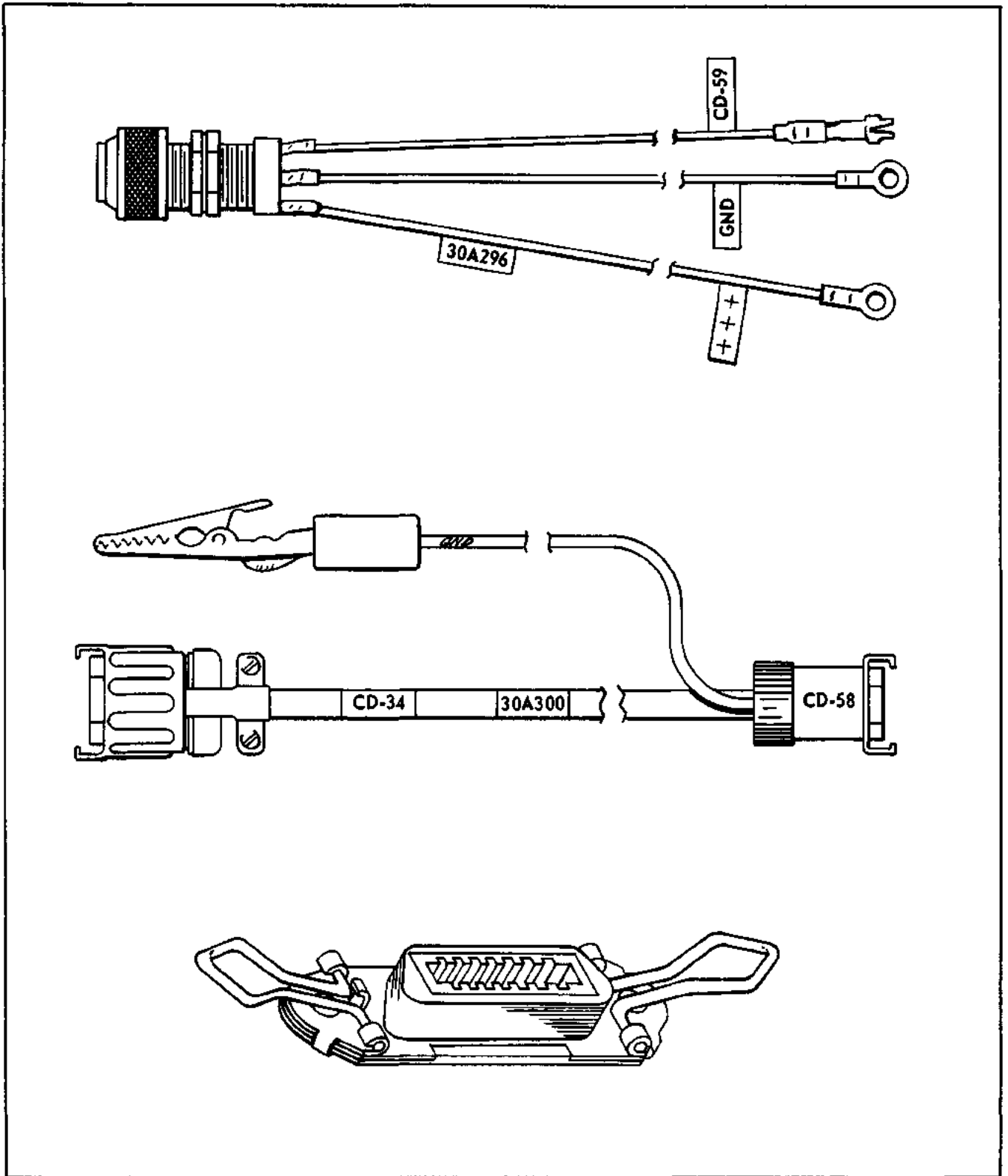

Figure 10-1. Glide Slope Coupler Test Cables and Jumper Plug

SECTION XI

BENCH SET-UP PROCEDURES

Paragraph	Page
11-1. Introduction	11-1
11-2. Equipment Required for Bench Check	11-1
11-3. Bench Checking of the Glide Slope Coupler	11-1
11-4. Wiring Diagrams	11-4

SECTION XI

BENCH SET-UP PROCEDURES

11-1. INTRODUCTION. The information in this section will list the equipment necessary to bench check the Glide Slope Coupler and the proper procedure for connecting this equipment. The bench set-up procedure is also described. For red button and adjusting pot location on Glide Slope Amplifier, refer to Figure 11-1. For functional ground and flight checks, refer to Section X. For Schematics, refer to paragraph 11-4 of this section.

11-2. EQUIPMENT REQUIRED FOR BENCH CHECK. The following test equipment will be required to bench check the Glide Slope Coupler.

- a. Gyro Substitute Test Box, 66D141-1.
- b. Power Section Test Box, 66D141-2.
- c. Radio Coupler Tester, 66D141-4.
- d. Console Substitute Test Box, 66D141-3.
- e. AltiMatic III Cable Harness, 30D207.
- f. Glide Slope Coupler Cable, 30C291.
- g. Glide Slope Coupler Test Cable, 30A300.
- h. Glide Slope Light and Cable, 30B317.
- i. AltiMatic IIC Amplifier.
- j. 14-Volt DC Power Supply or 28-Volt DC Power Supply, whichever is applicable.

11-3. BENCH CHECKING OF THE GLIDE SLOPE COUPLER.

a. Use the 66D141 Test Kit and make the following connections. After all connections are made as described in Steps 1 to 27 incl. proceed to bench check.

1. Make sure VOLTAGE SELECTOR SWITCH, located on top plate of amplifier is in correct position (14-volt DC or 28-volt DC) to match bench power supply.
2. Position amplifier so that 30-pin amplifier board is visible.
3. Plug large 30-pin AMP connector of the AltiMatic III test harness onto the amplifier board with the cable fanning out to the right. Identification placard on the amplifier should be visible.
4. Plug AMP connector CD-20 from the test harness into the CD-20 receptacle located on the Console Substitute Test Box.
5. Plug the 4-pin male CD-16 connector from the test harness into the female 4-pin receptacle located on the right hand side of the Power Section Test Box. This receptacle is labeled AMPLIFIER. On the Power Section Test Box, find the Voltage Selector Switch on the lower left hand corner and insure that this switch is positioned to match the bench power supply and the Amplifier Voltage Selector Switch in Step 1. (14 volts DC or 28-volts DC.)
6. Rotate SELECTOR KNOB on Power Section Test Box to the CENTER or "OFF" position.
7. Find the RADIO SIGNAL SUBSTITUTE KNOB located on the RADIO COUPLER TEST BOX, immediately to the right of the bottom Omni Meter. MAKE SURE THIS RADIO SIGNAL KNOB IS IN THE "IN" POSITION.
8. Find the VOLTAGE SELECTOR SWITCH located immediately to the left of the Red and Black DC input terminals on the face of the Radio Coupler Test Box. Place this VOLTAGE SELECTOR SWITCH in the proper voltage position.
9. Rotate LARGE VERNIER CONTROL KNOB on face of Gyro Substitute Test Box to the CENTER or "ZERO" position on the BOTTOM SCALE labeled PITCH DEGREES.

10. Below the Large Vernier Knob on the Gyro Substitute Box find a SLIDE SWITCH labeled "ROLL" and "PITCH." Place this slide switch in the "DOWN" or "PITCH" position.
11. Connect a ground lead to the bottom mounting flange of the AltiMatic Amplifier.

CAUTION

DO NOT PLACE THE GROUND LEAD NEAR THE OUTPUT TRANSISTORS LOCATED BETWEEN THE COOLING FINS ALONG THE SIDE OF THE AMPLIFIER.

12. Place the POWER SELECTOR SWITCH located on the lower left hand corner of the Console Substitute Test Box to the DOWN or "OFF" position.
13. Attach the DELCO fitting from the white wire CD-27 to the positive side of the power supply.
14. Immediately to the right of the AMP connector CD-20, find a 14-volt or 28-volt SLIDE SWITCH, place this switch to the proper voltage position to agree with Voltage Selector Switch on the top plate of the amplifier.
15. On the Console Substitute Test Box, place the Altitude Selector Switch in the Altitude Control position.
16. Connect the 24-pin male plug of the 30C291 harness to the Glide Slope Coupler.
17. Connect the FEMALE CD-10 of Glide Slope Coupler Harness (30C291) to the CD-10 connector on the Console Substitute Box.
18. Connect the MALE CD-10 of Glide Slope Coupler Harness (30C291) to the female CD-10 of the AltiMatic Test Harness.
19. Connect FEMALE CD-18 of the Glide Slope Coupler Harness to CD-18 on the Gyro Substitute Box.
20. Connect MALE CD-18 of the Glide Slope Coupler Harness to the female CD-18 connector of the AltiMatic Harness.
21. Connect Power Supply of either 14-volts or 28-volts A+ whichever is applicable to Glide Slope Harness as listed below:
 - 14-volt A+ connects to CD-61
 - 28-volt A+ connects to CD-62
22. Connect ground lead from 30B317 Light Assembly to Power Supply Ground.
23. Connect Glide Slope Harness CD-60 to Power Supply Ground.
24. Connect Glide Slope Coupler Harness CD-59 to the appropriate (14 or 28-volts) CD-59 of the 30B317 Light Assembly.
25. Connect the CD-34 end of the 30A300 Test Cable to the CD-34 (Radio) receptacle of the 66D141-4 Coupler Tester.
26. Connect the CD-58 end of 30A300 Test Cable to CD-58 of the Glide Slope Coupler Harness.
27. Connect the single lead of the 30A300 Test Cable to ground.

NOTE

Normally the Glide Slope Coupler logic circuit receives its ground from Pin K (loc norm) of the Radio Coupler; however, when using test cable 30A300 ground is obtained through an external lead which permits normal Glide Slope Coupler operation regardless of Radio Coupler Mode.

28. Turn Power Supply "ON."

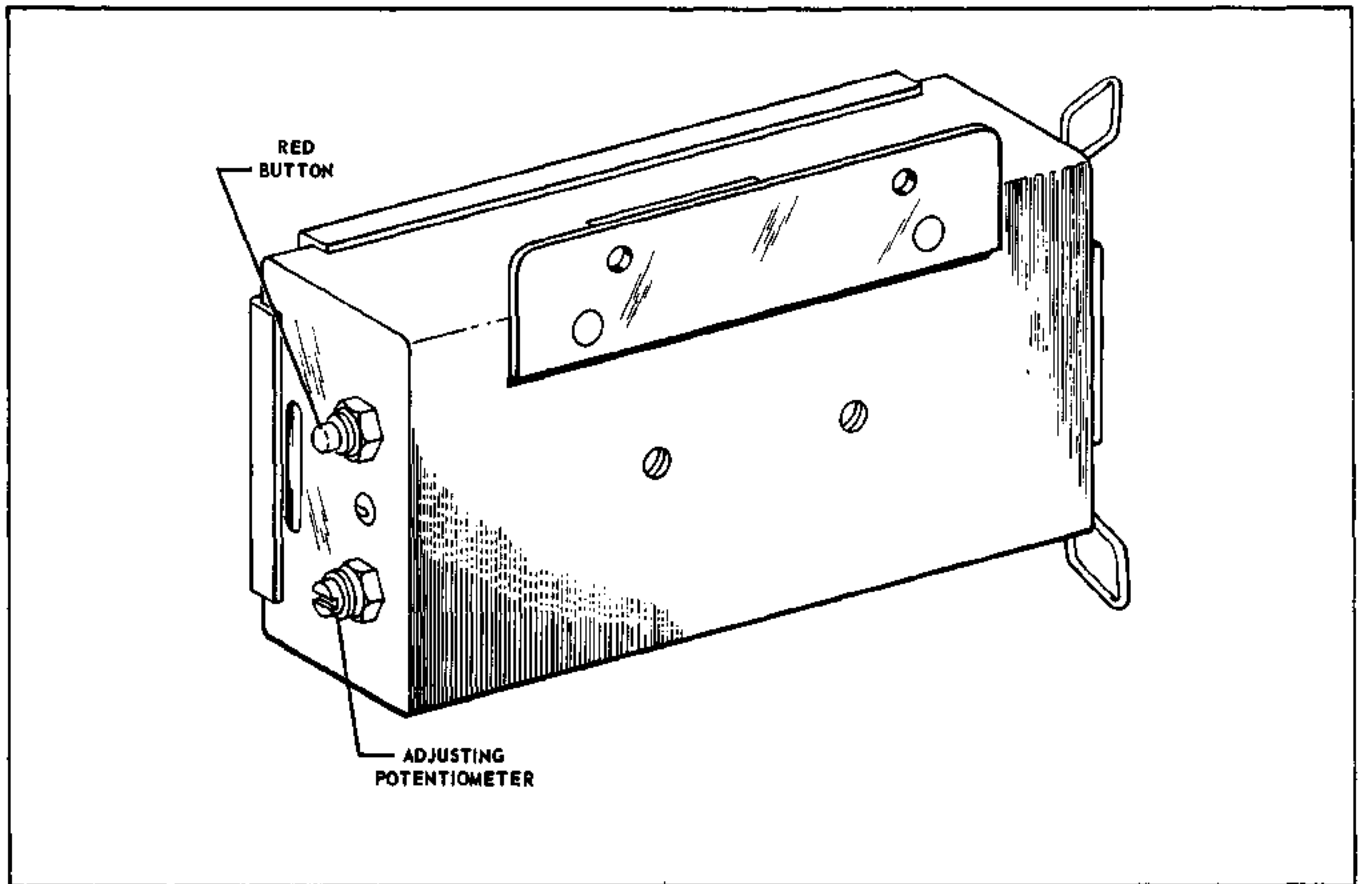

Figure 11-1. Glide Slope Coupler

29. Place the ON/OFF switch, located in the lower left corner of the Console Substitute Test Box in the ON position. Depress RED BUTTON located at BOTTOM RIGHT corner of Power Section Test Box labeled INPUT VOLTAGE. Test box needle should deflect to the right and read 12-14 or 24-28 volts DC, whichever is applicable, on TOP SCALE.

30. Place the Selector Switch on the Power Section Test Box to the "Res" position.

31. On the Console Substitute Test Box, center the Altitude Control Knob and adjust the Pitch Trim Knob to center the needle on the Power Section Test Box.

32. Pull OUT radio signal knob on Radio Coupler Tester, rotate COUNTERCLOCKWISE to obtain 60% in the blue.

NOTE

With reference to the Glide Slope Coupler, blue is UP and yellow is DOWN.

33. To ARM the Glide Slope Coupler, maintain 60% for 20 seconds.

34. Reduce radio signal slowly by rotating the Radio Signal Knob clockwise until "LOCK ON" occurs. This can be determined by the green indicator light coming on. Also, an audible "click" will be detected from the relay.

35. Push Radio Signal Knob OFF. (This keeps needle centered.)

36. Rotate slot head potentiometer on glide slope coupler full clockwise. (Refer to Figure 11-1.)
 37. With red button depressed, center output meter on Power Section Test Box by rotating the large vernier knob clockwise. On the scale labeled "Pitch Degrees," record the degrees required to center the needle.
 38. Rotate slot head potentiometer on glide slope coupler full counterclockwise.
 39. Depress red button on glide slope coupler and center output meter on Power Section Test Box by rotating the large vernier knob counterclockwise. On the scale labeled "Pitch Degrees," record the degrees required to center the needle.
 40. The total separation between the reading obtained in Step 37 and the reading obtained in Step 39 should be $6^{\circ} - 2^{\circ} + 3^{\circ}$.
 41. Center the Attitude Gyro Knob.
 42. Adjust the Potentiometer on the Glide Slope Coupler to approximately MID POINT.
 43. Depress red button on glide slope coupler. Pull out Radio Signal Knob and rotate it counterclockwise to obtain 100% UP (blue). Zero the output meter by rotating the large vernier knob clockwise. Record the degrees required to zero the output meter on the Power Section Test Box.
 44. Continue to depress Red Button on Glide Slope Coupler. Rotate Radio Signal Knob to deflect the Radio Signal Meter to 100% DOWN (yellow). Zero the output meter by rotating the large vernier knob counterclockwise. Record the degrees required to zero the output meter on the Power Section Test Box.
 45. The total separation between the reading obtained in Step 43 and the reading obtained in Step 44 should be $7^{\circ} + 2^{\circ}$.
 46. With red button released and the Radio Signal Meter indicating 100% DOWN (yellow) rotate the large vernier knob on the Gyro Substitute Test Box counterclockwise until the output meter is centered. WAIT 90 SECONDS. Record the reading on the "Pitch Degrees" scale.
 47. With red button released and the Radio Signal Meter indicating 100% UP (blue), rotate the large vernier knob on the Gyro Substitute Test Box clockwise until the output meter is centered. WAIT 90 SECONDS.
 48. The total separation between Step 46 and 47 should not exceed $10^{\circ} \pm 2^{\circ}$.
- b. INTEGRATOR RATE TEST.
1. Push Radio Signal Substitute Knob "IN" and momentarily depress red button on glide slope coupler.
 2. Center the output meter on Power Section Test Box by rotating the large vernier knob on the Gyro Substitute Test Box. WAIT 30 SECONDS after final rotation of knob.
 3. Pull Radio Signal Substitute Knob "OUT."
 4. With button released, obtain 20% UP (blue) indication on Radio Signal Meter, allow 90 seconds for Integrator to stabilize. Reverse Radio Signal to 20% DOWN (yellow). IMMEDIATELY record the time required for the needle on the Power Section Test Box to pass through zero from a right deflection. Time should be 15 to 35 seconds, observe needle now deflects left.
 5. Push Radio Signal Knob "IN."
 6. Rotate the large vernier knob counterclockwise 2° nose down.
 7. Depress Red Button on Glide Slope Coupler and adjust potentiometer on glide slope coupler to center Output Meter on Power Section Test Box.
- c. This completes Bench Set-Up.

11-4. WIRING DIAGRAMS. The following pages consist of wiring diagrams of the electrical harnesses and mating connectors which pertain to the glide slope coupler. This information should be utilized when troubleshooting the system for defective wiring. A continuity test of wiring can be performed with an ohmmeter. This test will verify the harness is good and capable of carrying current. Should any wire or connector fail to produce a reading on the ohmmeter, they are defective and must be repaired or replaced.

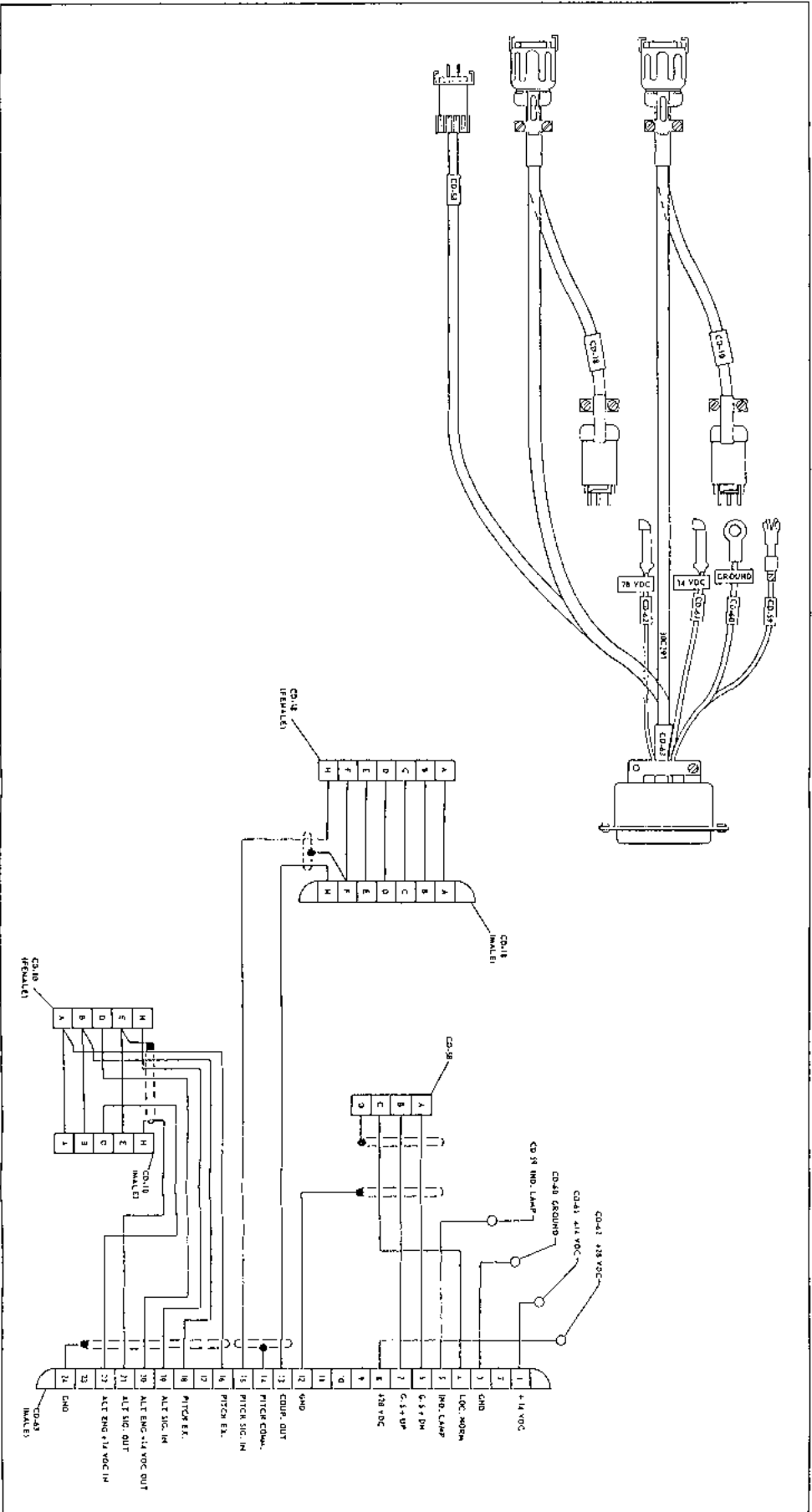

Figure 11-2. Glide Slope Coupler Harness

BENCH SET-UP PROCEDURES
 REVISED: 6/13/75

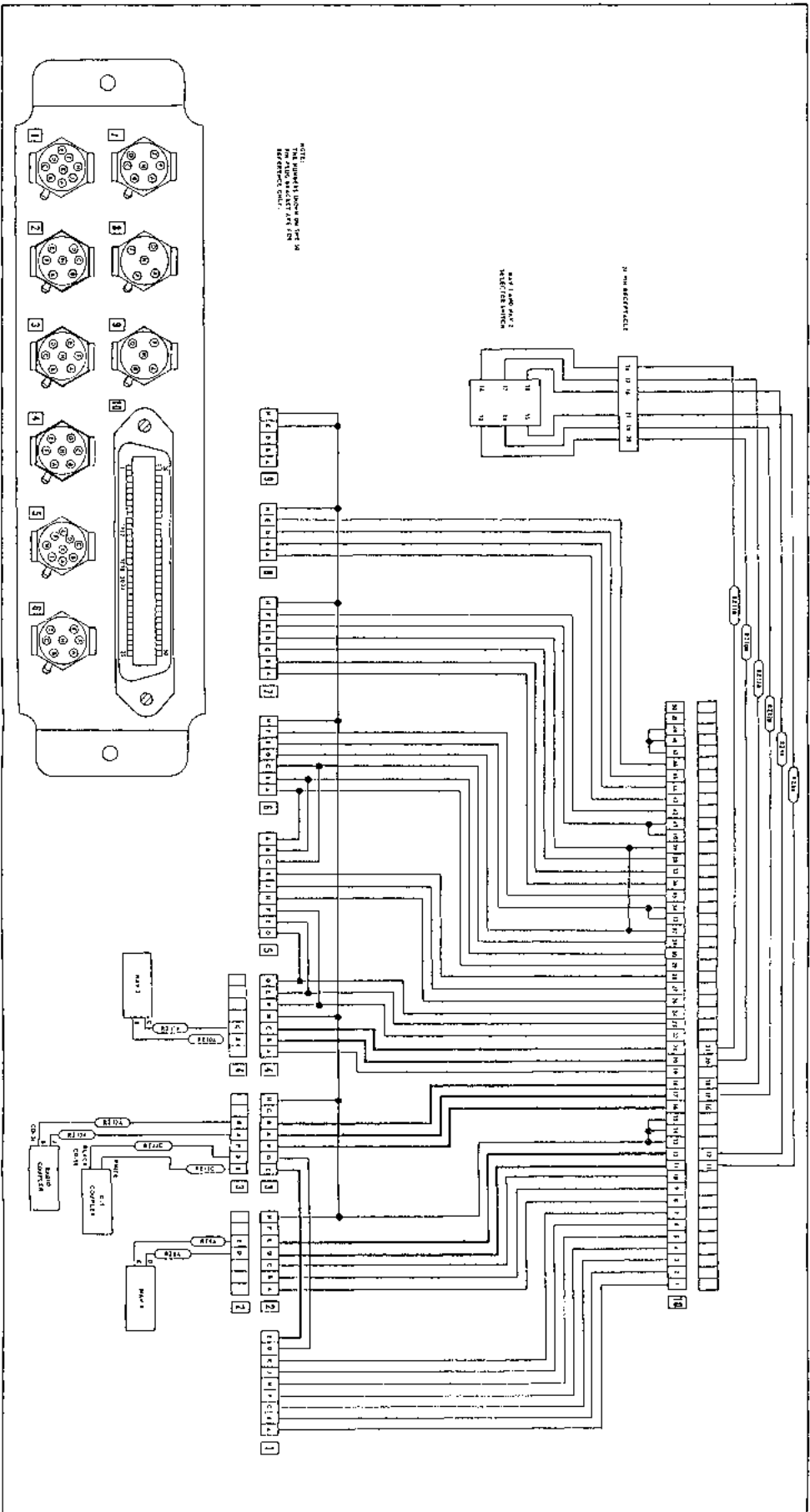

Figure 11-3. Plug Bracket Schematic for Altimatic IHC With Slide Slope Coupler, PA-31

SECTION XII

GROUND CHECK AND FLIGHT SET-UP PROCEDURES

Paragraph	Page
12-1. Ground Operational Check	12-1
12-2. Flight Set-Up Procedures	12-1

SECTION XII

GROUND CHECK AND FLIGHT SET-UP PROCEDURES

NOTE

Normally the Glide Slope Coupler logic circuit receives its ground from Pin K (loc norm) of the Radio Coupler; however, when using test cable 30A300 ground is obtained through an external lead which permits normal Glide Slope Coupler operation regardless of Radio Coupler Mode.

12-1. GROUND OPERATIONAL CHECK.

- a. Remove aircraft harness connector CD-58 from glide slope coupler and connect test cable 30A300 CD-58 to glide slope coupler. Connect CD-34 end of the 30A300 test cable to the receptacle labeled CD-34 (radio) on the coupler tester, 66D141-4. Attach the lead labeled "Ground" of the 30A300 test cable to the airplane ground.
- b. On the 66D141-4 Radio Coupler Tester, adjust the Lower Radio Signal Meter for 60% UP (blue).
- c. Connect CD-18 of the Glide Slope Harness to the 66D141-1 Gyro Substitute Test Box.
- d. With the aircraft master switch ON engage the AltiMatic IIC, make sure it is in the ALT Hold Mode.
- e. After 20 seconds slowly decrease the Radio Simulator Signal, the coupler should lock ON when zero output is indicated on the Radio Signal Meter. The green light also indicates lock ON.
- f. Alternately rotate the Radio Signal Substitute Knob to UP (blue) and DOWN (yellow) 60% positions. Note that the stabilator or elevator moves accordingly.

NOTE

Response will not be immediate when reversing radio signal as it will take time for the integrator to stabilize.

12-2. FLIGHT SET-UP PROCEDURES. The flight adjustment is provided for the purpose of establishing the correct pitch attitude required to maintain the Glide Path Track. This minimizes the corrective action required of the error integrator to maintain tracking with the Glide Slope Converter centered.

- a. Remove the glide slope coupler by removing the two mounting screws which are located on the mounting flange.
- b. Connect one end of CD-63 extension cable to the 30C291 harness installed in the airplane. Connect the other end of this extension cable to the CD-63 receptacle on the glide slope coupler.
- c. Connect CD-58 cable from glide slope coupler to CD-58 of the Mitchell P/N 30A300 Test Cable (Piper P/N 757 874). Connect CD-34 of the Test Cable to CD-34 receptacle on the Radio Coupler Tester 66D141-4. Connect the single lead of the 30A300 test cable to the airplane ground.

- d. Fly to an area clear of traffic and off the airways. Also fly to an altitude sufficient to make a simulated approach and descent.
- e. With the autopilot operating, engage ALT Hold.
- f. Establish approach speed with gear down and flaps set in accordance with appropriate Airplane Flight Manual. (Not to exceed 15).
- g. PULL Radio Signal Substitute Knob, on 66D141-4 Test Box, OUT and rotate it counterclockwise to 100% blue indication. This is equivalent to being under the glide slope which is necessary to arm the glide slope coupler.
- h. Maintain 100% UP signal for approximately 20 seconds then slowly rotate the Radio Signal Substitute Knob to center the needle.
- i. As needle crosses center, glide slope coupler will "Lock ON," which can be noted by the green indicator light coming on. The aircraft will pitch slightly to a nose down attitude.
- j. Push Radio Signal Substitute Knob OFF (in). This is equivalent to Glide Slope Coupler Needle being centered.
- k. Adjust power to maintain approach airspeed.
- l. Depress red button on glide slope coupler and adjust adjacent potentiometer to set a 500 feet per minute descent. (Clockwise is UP.)
- m. Repeat procedure to be sure adjustment is satisfactory.
- n. Disconnect test cable 30A300 and connect Glide Slope Coupler CD-58 to Glide Slope Indicator CD-58 connector.
- o. Disconnect extension cable CD-63 and connect aircraft CD-63 to the glide slope coupler. Make a coupled ILS approach.
- p. Reinstall Glide Slope Coupler in the airplane.

PART III
ALTIMATIC IIC
| ELECTRONIC PITCH TRIM

REVISED: 10/16/81

SECTION XIII

INTRODUCTION AND DESCRIPTION

Paragraph	Page
13-1. Introduction	13-1
13-2. Description	13-1

SECTION XIII

INTRODUCTION AND DESCRIPTION

13-1. INTRODUCTION. This part of the service manual is divided into four sections. Section XIII, contains a description of the AltiMatic IIC Pitch Trim System. Section XIV, Theory of Operation, explains the functional operation of the system. Section XV explains the proper ground check of the system, and Section XVI provides a Troubleshooting Isolation Block Diagram.

13-2. DESCRIPTION. The AltiMatic IIC Electronic Pitch Trim System has both a manual mode of operation and an automatic mode of operation. The manual mode is operational only when the autopilot is disengaged or the roll axis only is engaged, and the automatic mode is operational only when the pitch axis of the autopilot is engaged.

a. **MANUAL MODE.** This mode applies to the trim system when the pitch portion of the autopilot is disengaged. Trim may be accomplished by the human pilot electrically by use of the trim switch on the pilot's control wheel. The disengage button is incorporated in the control wheel mounted trim switch and must be depressed to make the electric trim switch effective. Also, the panel mounted Trim Master Switch must be pushed to the ON position. When the trim switch is moved to the forward position with the disengage button depressed, it completes a circuit to the servo motor, at the same time, power is applied to a solenoid which engages the trim servo motor to the capstan through a set of gears. Since the trim system cables are wrapped around the capstan, any rotation of the trim servo motor results in a change of position of the airplane's trim system, thus deflecting the stabilator or elevator trim tab in the conventional manner. When the human pilot releases the switch, it returns to the OFF position and power is then disconnected from the trim servo motor and the engage solenoid which completely disengages the electric trim motor from the airplane's trim system cables. If the switch is moved to the rear position, the same events occur except the polarity of the servo motor is reversed insuring the opposite direction of rotation.

b. **AUTOMATIC MODE.** When the Roll and Pitch engage switches on the AltiMatic IIC Console are engaged, the trim switch on the pilot's control wheel becomes inoperative and electrical power is applied to the electronic trim amplifier and pitch trim servo engage solenoid. The electronic trim amplifier electronically senses trim requirements and adjusts the trim as required by providing electrical power sufficient to drive the DC trim servo motor.

NOTE

The engage solenoid will maintain engagement of the servo motor and capstan gears continuously while the pitch axis of the Autopilot is engaged.

SECTION XIV

THEORY OF OPERATION

Paragraph		Page
14-1.	System Explanation	14-1

SECTION XIV

THEORY OF OPERATION

14-1. SYSTEM EXPLANATION:

The AltiMatic IIC Autopilot utilizes an Electronic Pitch Trim System in place of the electro-mechanical system used in previous EDO/MITCHELL equipment. An Electronic Pitch Trim Amplifier takes the place of the Mechanical Pitch Trim Sensor Assembly used to monitor stabilator/elevator cable tension.

a. **AUTOMATIC MODE.** In the Automatic Mode (Autopilot pitch axis engaged), the Electronic Pitch Trim Amplifier monitors the analog voltage being applied to the autopilot pitch servo. Depending on the amount of voltage and the time period voltage is present and changing, the Electronic Trim Amplifier pulses the pitch trim servo motor in either very slow pulses, for minute pitch trim change, or higher frequency pulses resulting in constant medium speed trim change.

b. **MANUAL MODE.** In the Manual Mode (Autopilot pitch axis dis-engaged), the Electronic Pitch Trim Amplifier operates the pitch trim servo at maximum speed.

This design offers fail-safe runaway trim protection, and can withstand any type single failure, without uncontrolled trim system results. Further, due to variable trim rates, the system is better suited to higher performance aircraft from an operational standpoint.

SECTION XV
GROUND CHECK - ELECTRONIC PITCH TRIM SYSTEM

Paragraph	Page
15-1. Ground Check - Electronic Pitch Trim System	15-1

SECTION XV

GROUND CHECK - ELECTRONIC PITCH TRIM SYSTEM

NOTE

It is very important to never use a substitute trim system component part, for an original design part, because the fail-safe characteristics of the system might be compromised. Perform the following ground checks before flight, when service has been performed. A trim system running the wrong direction, is the same as a run-away. It is possible to experience excessive pilot yoke forces in only 3-4 seconds under such conditions.

15-1. GROUND CHECK OF ELECTRONIC PITCH TRIM SYSTEM.

1. MANUAL MODE.
 - a. Run engines to erect gyros on a level ramp.
 - b. Check - trim circuit breaker "IN".

MANUAL ELECTRIC TRIM

When the AltiMatic IIC is disengaged, the pilot can adjust pitch trim electrically through a switch on the pilot's control wheel (see Figure 15-1). The Master A/P Disconnect/Trim Interrupt Switch (located on the pilot's control wheel) will disconnect the Autopilot and Yaw Damper when pressed and released. When pressed and held this switch will interrupt all electric trim operations.

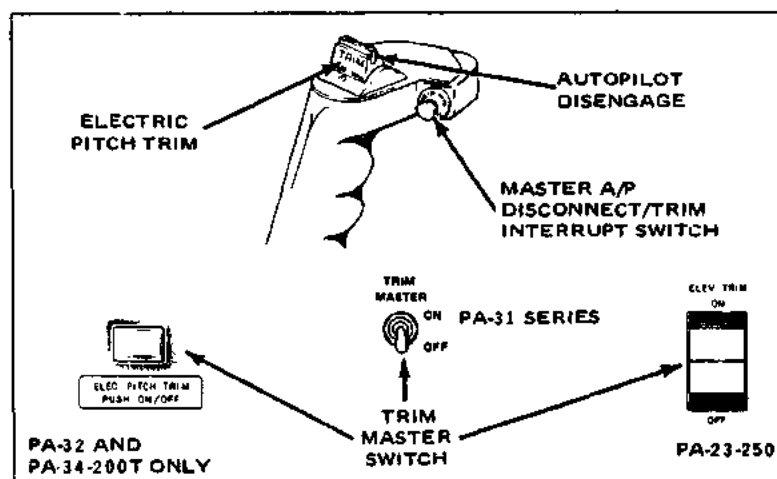

Figure 15-1

- c. Turn ON TRIM MASTER SWITCH (Ref. Fig. 15-1).
- d. ENGAGE ROLL on Autopilot Console and ROTATE ROLL COMMAND KNOB to stop Control Yoke/Aileron action.
- e. PULL AND HOLD CONTROL YOKE to neutral/level flight position.
- f. ENGAGE PITCH on Autopilot Console and ROTATE PITCH COMMAND DISK to stop Control Yoke/Elevator-Stabilator action.

NOTE

It may be necessary to manually assist Pitch Servo to support Elevator/Stabilator Weight on ground, due to clutch slip point setting.

- g. DEPRESS MASTER A/P DISCONNECT/TRIM INTERRUPT SWITCH (Button-Ref. Fig. 15-1) on pilot's control yoke, to verify this switch immediately disconnects Autopilot.
- h. HOLD THIS MASTER A/P DISCONNECT/TRIM INTERRUPT SWITCH IN and actuate AUTOPILOT/ELECTRIC PITCH TRIM SWITCH (Rocker-Ref. Fig. 15-1) on pilot's control yoke to verify this rocker switch is now inoperative.
- i. RELEASE MASTER A/P DISCONNECT BUTTON.
- j. Repeat Steps d, e, and f above and DEPRESS AUTOPILOT/ELECTRIC PITCH TRIM ROCKER SWITCH on pilot's control yoke; to verify this rocker switch, also, immediately disengages Autopilot.
- k. DO NOT RE-ENGAGE AUTOPILOT.
- l. Again DEPRESS AUTOPILOT/ELECTRIC PITCH TRIM ROCKER SWITCH, AND while Top Bar is depressed, move switch AFT - check that PITCH TRIM moves UP.
- m. While continuing to depress AUTOPILOT/ELECTRIC PITCH TRIM ROCKER SWITCH, move this rocker switch FORWARD - check that PITCH TRIM moves DOWN.
- n. RELEASE PRESSURE on Top Bar of switch. Verify the AUTOPILOT/ELECTRIC TRIM SWITCH is inoperative in both directions, if Top Bar of rocker switch is not depressed.

2. AUTOMATIC MODE.

In this mode there will be approximately a 3-second DELAYED Pitch Trim response, after a pitch change is commanded on the Autopilot Console.

- a. ENGAGE ROLL on Autopilot Console and rotate ROLL COMMAND KNOB to stop Control Yoke/Aileron motion.
- b. PULL AND HOLD CONTROL YOKE to a neutral or level flight position.
- c. ENGAGE PITCH on Autopilot Console, and ROTATE PITCH COMMAND DISK to stop Control Yoke/Elevator-Stabilator action.

NOTE

It may be necessary to manually assist Pitch Servo to support Elevator/Stabilator Weight on ground due to clutch slip point setting.

- d. ROTATE PITCH COMMAND DISK for UP Command. Observe PITCH TRIM follows with UP TRIM after approximately 3-second delay.
- e. ROTATE PITCH COMMAND DISK for DOWN Command. Observe PITCH TRIM follows with DOWN TRIM after approximately 3-second delay.

NOTE

The Pitch Trim Servo response speed may not resemble earlier altimatic models. The Electronic Pitch Trim Amplifier will determine if slow pulse or medium pulse trim servo speed will occur. If very slow pulses of pitch trim appear before higher pitch trim speed occurs — **DO NOT MISINTERPRET THIS OCCURANCE AS A FAULT.**

- f. This completes the ground checks of the Electronic Pitch Trim System.

SECTION XVI
TROUBLESHOOTING

Paragraph	Page
16-1. Introduction & Isolation Block Diagram	16-1

SECTION XVI
INTRODUCTION

16-1. INTRODUCTION. The AltiMatic IIC Autopilot is equipped with Electronic Pitch Trim. No special test equipment or adjustments are required with this system. For appropriate wiring diagrams of the trim system refer to Section VI of this manual as the trim system is part of the autopilot. Utilize the wiring diagrams to troubleshoot the system.

TROUBLE ISOLATION BLOCK DIAGRAM
TABLE XVI-I.

