

TURBO TWIN COMANCHE

OWNER'S MANUAL

MANUFACTURED BY

RAJAY CORPORATION

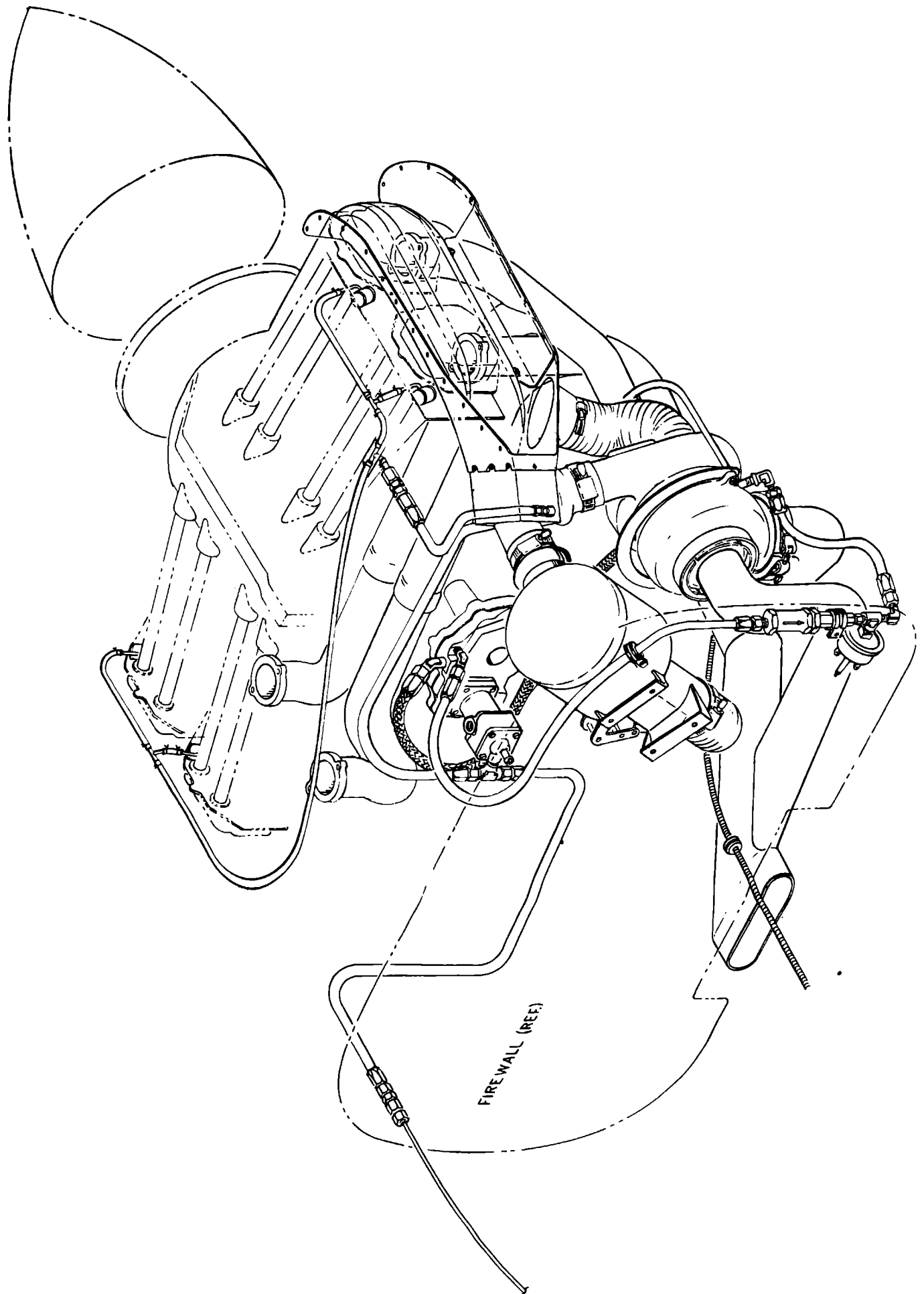

RAJAY

TURBO TWIN COMANCHE

PIPER PA 30

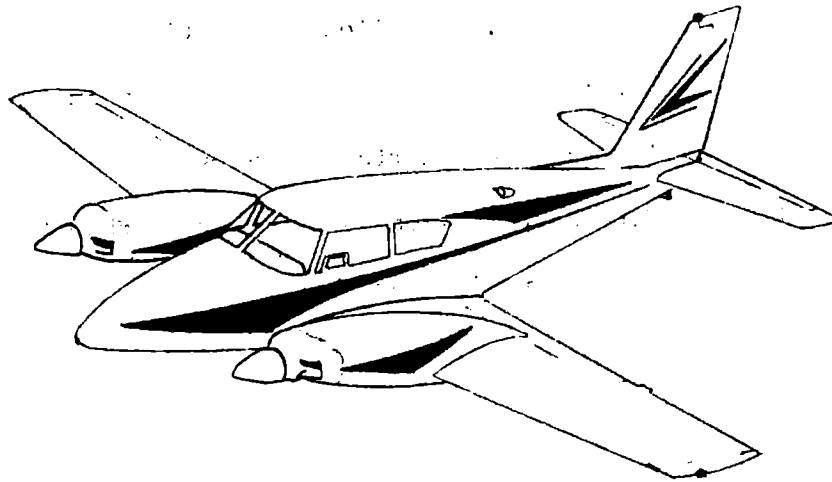

OWNERS MANUAL

SECTIONS

1. OPERATION
2. SERVICE
3. ILLUSTRATED PARTS

TABLE OF CONTENTS

OPERATION

Page 1	Section I. Introduction
Page 2	Section II. Description of Concept
Page 3	Section III. Flight Operational Procedure
Page 5	Section IV. Detailed Description
Page 11	Air Induction and Exhaust Gas Flow Schematic
Page 12	Turbocharger Lubrication System
Page 13	Turbocharger Waste Gate Control Schematic
Page 14	Turbocharged Power Chart

SECTION I

INTRODUCTION

All naturally aspirated internal combustion engines have a reduction of full throttle sea level power output as they attain altitude. This is because the air is progressively less dense at all altitudes above sea level. It is the purpose of this manual to describe the simple, reliable and economical Rajay Turbocharger system installed on your aircraft. This system will provide normal sea level cruise power up through 20,000 feet.

THIS CONCEPT IS KNOWN AS TURBONORMALIZING -----

SECTION II
DESCRIPTION OF CONCEPT

Turbonormalizing is accomplished with a turbocharger. This a centrifugal compressor which is driven by a turbine that shares a common shaft with the compressor; all of which are enclosed in appropriate compact housings to form a simple unit. The turbine of the turbocharger is driven by normally wasted exhaust gas energy supplied from the engine which breathes air pumped to it by the centrifugal compressor of the turbocharger unit. The amount of boost pressure (and resulting power from the engine) is controlled by the pilot with an exhaust gas by-pass valve (waste gate).

The waste gate is actuated manually by remote control at the pilot's command to obtain an increase in engine manifold air pressure (MAP) and increase in power.

The main benefits of this concept for aircraft use are:

1. Allows normal sea level cruise power to be safely taken from the engine at high altitudes (TURBONORMALIZING).
2. Provides additional safety over mountains or when topping weather by substantially increasing the single engine ceiling of your aircraft.
3. Will provide more basic altitude capacity for seeking the aid of favorable tail winds and for avoiding excessive head winds or turbulence.
4. Range for a given fuel load will be increased. This is because the sea level cruise power can be taken from the engine at high altitudes where the drag is reduced, resulting in more "miles per gallon."
5. Completely eliminates the hazard of venturi ice while turbocharging.
6. Because the drag of the aircraft is reduced at 8,000 feet to 20,000 feet altitude with the engine capable of normal sea level cruise power, the true air speed (TAS) will increase.

It should be pointed out here that the usual concept of altitude "TURBONORMALIZING" with the use of a turbocharger does in no way increase the normal speed, loads or BMEP limits already established as safe for aircraft engines. The only condition which is different from normal power condition is the engine air inlet temperature. This is higher than normal due to compressing the air with the turbocompressor before it is ducted to the engine air inlet. Detonation danger, as a result of this higher engine air inlet temperature is completely avoided by the use of 100/130 octane fuel.

SECTION III

TYPICAL "TURBONORMALIZED FLIGHT OPERATIONAL PROCEDURE

Since "TURBONORMALIZING" is a relatively new concept as applied to the civil aircraft industry, it is appropriate at this point to describe a typical flight operational procedure and installation. This is to acquaint the operator with some of the basic background thinking pertaining to this "TURBONORMALIZING" concept.

FLIGHT PROCEDURE:

The operation of the turbocharger from the pilot's point of view is extremely simple. The projected typical flight operation sequence is as follows:

1. The pre-flight, take-off and climb to 2-5,000 feet is as now prescribed for the aircraft.
2. During the climb at the above indicated altitude range, the pilot will have reached the full throttle position, the turbochargers will be put into operation to maintain the desired power (28"/HgA 2600 RPM, METO). At this point, the pilot will start closure of the exhaust gas waste-gate valve with the separate controls located on the powerplant control console. This diverts exhaust gases through the turbine section of the turbochargers. This in turn activates the turbochargers and allows the pilot to maintain the desired manifold pressure during climb to approximately 20,000 feet density altitude. Typical engine conditions for climb would be:
 - a. 2700 RPM Max. for all operating conditions (5 min. max. when turbocharged). 2600 RPM METO. 2200 RPM minimum when utilizing the turbochargers.
 - b. Manifold pressure - 22" to 28" HgA when turbocharged.
 - c. 350° to 450°F cylinder head temperature with turbochargers operating.
3. Upon obtaining the desired cruising altitude, reduce power to 22" - 28" HgA MAP and the RPM to 2200 - 2400 RPM cruise range. The aircraft will then be trimmed for cruise speed and the fuel air mixture adjusted for best economy. NOTE: Operating practice shows that leaning can readily be done below 75% rated power. Leaning should be done in the usual manner by pulling the mixture control back slowly, watching the manifold pressure rise to a peak; then advance (richen) the mixture for a loss of $\frac{1}{2}$ to $\frac{1}{2}$ "HgA - then readjust turbocharger controls to return to the desired power setting. Other techniques such as leaning until a slight yaw is felt or until unsteady engine operation, then enriching to smooth engine will work equally well. Leaning should

SECTION III (con't)

always be done for sustained cruise because the fuel saving can be as much as two or three gallons per hour. Use of Exhaust Gas Temp Indicator should be per engine manufacturer's recommendations.

4. The turbochargers may be utilized to obtain take off power at high altitude airfields. (Observe Take Off manifold pressure limit) Mixture Full Rich.
5. For descent, power is reduced in the reverse sequence as applying power; decrease manifold pressure by moving the Turbocharger Control toward "OFF". To further reduce power, retard the throttle.

Note: Leaner mixture will be required at the higher altitudes with the turbochargers inoperative. In summary, the only additional duty the pilot has is to control the manifold pressure by the use of the turbocharger control after reaching the full throttle position during climbout.

SECTION IV
DETAILED DESCRIPTION

1. INDUCTION SYSTEM

The induction system is arranged to use the original engine throttle and fuel mixture controls. The inlet air box has been designed to accommodate the compressor discharge air for TURBONORMALIZING without penalizing the naturally aspirated take off power. Alternate air is available automatically in the event of normal inlet duct stoppage or may be selected from the cockpit by the original alternate air controls. Alternate air is available only during naturally aspirated operation. Refer to page 11 for air flow diagram.

As can be observed from the diagram, normal naturally aspirated power is automatically restored by the opening of the check valve door in the event the turbocompressor doesn't deliver boost pressure. The safety advantage of this feature is obvious. Another advantage of this inlet check valve is that it avoids the prohibitive throttling pressure drop (with corresponding loss of power) which would occur if all the engine air for naturally aspirated operation is routed through the inoperative compressor. The new filter can assembly is installed in the original filter location for ease of servicing.

2. EXHAUST SYSTEM

a. Exhaust Stacks

New exhaust stacks are fabricated and installed to accommodate the waste gate, turbine inlet and exhaust ducting.

b. The Waste Gate

The waste gate assembly is shown in the diagram on Page 13. It is comprised of a housing, valve and control arm. The

SECTION IV (con't)

waste gate assembly is the primary control device for the turbocharger. Control is accomplished by varying positions of the waste gate valve, diverting a controlled amount of exhaust gas through the turbocharger thus compressing engine inlet air to the desired pressure.

c. The Turbocharger Turbine Ducting

This is designed in such a manner that right and left hand engine installations are identical. As can be observed from the installation sketch, this is a very compact arrangement which provides lightweight and reliable exhaust ducting. The turbine discharge duct is "S" shaped and discharges through the existing cowl opening.

3. FUEL SYSTEM

The fuel system is one of the most critical systems in the power plant. A clear understanding of operation and good maintenance are necessary to get the very best reliability and performance.

a. Fuel Pump

The positive displacement rotary fuel pumps installed on the Turbo Twin Comanche are required for satisfactory Turbocharger operation. The pressure regulating section of the engine-driven pumps are referenced to turbocompressor discharge pressure to insure proper fuel pressure programming when the engine is "TURBONORMALIZED."

b. Fuel Flow Gauge

The standard fuel flow gauge will provide an indication of fuel flow in the usual manner when naturally aspirated or "Turbonormalized." This is made possible by connecting the vent

SECTION IV (con't)

section of the fuel flow gauge to turbocompressor boost pressure.

- c. Fuel boost pump is standard as installed in the airplane, since no additional performance is required above the standard installation.

4. TURBOCHARGER DESCRIPTION

The turbocharger is a 13.0 pound unit of high speed turbine equipment designed by Thompson Ramo Wooldridge Corporation primarily for use on small, high performance diesel engines. This basic turbocharger design has been modified to be compatible with the aircraft power plant application described herein. It consists of a precision balanced rotating shaft with a radial inflow turbine wheel on one end and a centrifugal compressor impeller on the other--each with its own housing. The turbine driven by the engine exhaust gases, powers the impeller which supplies air under pressure to the engine air inlet. This higher than ambient air pressure supplies more air by weight to the engine with the advantage of a proportionately higher power output with minimum increase in size and weight. This turbocharger represents the ultimate in product quality and performance. The rotating unit and bearings are designed for reliable service in excess of 1000 hours which equals the major overhaul period capabilities of most engines. The compressor and turbine component efficiencies are so superior that if the proper engine installation matching is done, the turbine inlet or engine exhaust pressure will be 10% to 15% less than the air throttle valve inlet pressure for recommended operating range. THIS MEANS THAT ENGINE HORSEPOWER IS NEVER USED TO DRIVE THE TURBOCHARGER. This, of course, says that no additional mechanical loads are imposed on the

SECTION IV (con't)

engine in the way of above normal present power. All of the work required to drive the turbine is recovered from the exhaust gases by, in effect, increasing the expansion ratio of the power portion of the basic engine cycle. Otherwise, if the turbocharger were not in that system, this portion of gas energy would be lost with discharged exhaust gases.

The turbocharger bearings are of the semi-floating, simple sleeve journal type with engine pressure lubrication for the best reliability. The turbine housing and turbine wheel are cast of high temperature resistant materials; the central main housing, compressor housing and impeller are cast of aluminum for lightweight and excellent thermal characteristics. As a result of this selection of materials and with care in installation, the turbocharger is completely air cooled.

In summary, the turbocharger used in this kit installation represents the applied results of 20 years of turbine materials knowledge and thermodynamic state-of-the-art. The individual development cost of this line of turbochargers has exceeded one million dollars.

5. TURBOCHARGER LUBRICATION AND LUBRICATION SCAVENGE SYSTEM

The turbocharger is designed to be lubricated by engine lubricant. This is supplied to the turbo oil gallery by a line connected to a fitting on the Engine Accessory Case. A fitting included in this lubricant supply line incorporates a pressure regulator poppet valve to reduce engine gallery oil pressure from 60 - 80 psi (required for the engine) to 30 - 50 psi pressure (at normal oil

SECTION IV (con't)

operating temperatures), Between 1 and 2 quarts per minute of lubricant will be supplied to the turbocharger. This quantity of oil is a very small percentage of total engine oil pump capacity. The oil quantity which is supplied to the turbocharger is normally returned to the engine sump by way of the by-pass pressure relief valve. A pressure switch is also incorporated in the turbocharger lubricant supply line which will activate a red warning light in the event turbocharger oil pressure is below 27-30 psi. In the event turbocharger oil pressure is low, the pilot simply removes the turbocharger from operation by pulling the turbocharger control to the "OFF" position which returns the engine to naturally aspirated (See item # 3 in Trouble Shooting Section) operation to save the turbocharger bearings. The turbocharger lube sump is scavenged and returned to the engine by the lube scavenge pump installed between the fuel pump and the engine accessory case.

6. TURBOCHARGER CONTROLS

As already indicated, the principal factor in turbocharger operation is exhaust gas waste-gate degree of closure. This determines the amount of the total engine exhaust gas flow through the turbine and resulting level of boost. To provide the pilot with complete freedom of choice in turbocharger use, a separate push-pull control with precise vernier adjustment is installed on each engine for actuation of the waste-gate. This installation permits convenient, exact matching of manifold pressures for the Turbo Twin Comanche twin engine installation. With respect to engine stability when using a turbocharger, tests conducted for this installation

SECTION IV (con't)

(and past similar installations) have clearly demonstrated that with a propeller governor or propeller type load, the engine is inherently stable. This is because the four cycle engine serves as a positive displacement device, thus controlling the air flow for steady power output. This means that control is a function of governed engine speed and exhaust waste-gate valve position.

INDUCTION AIR AND EXHAUST GAS FLOW SCHEMATIC

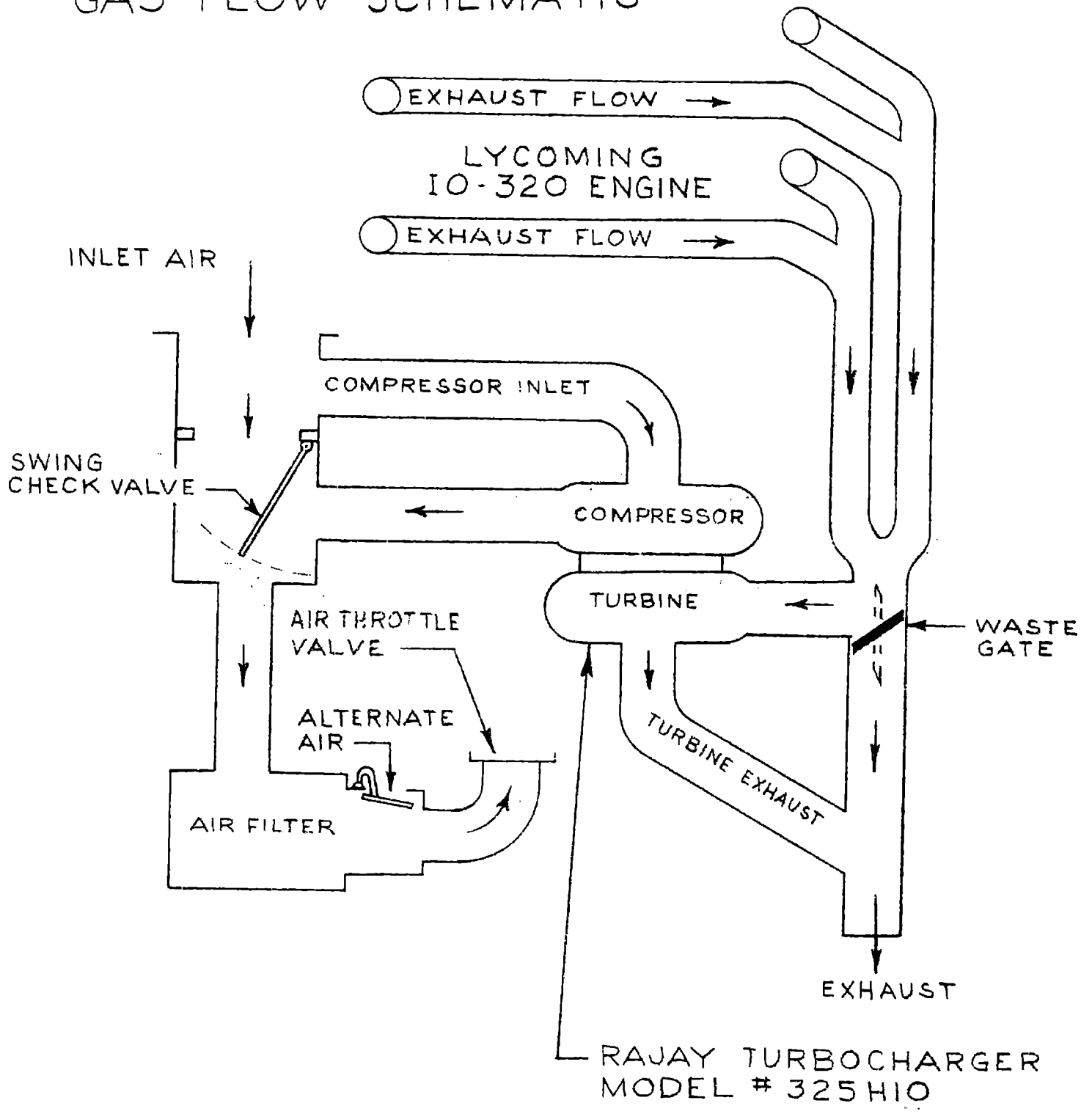

WASTE GATE OPEN - - - -
 WASTE GATE CLOSED ————

TURBO TWIN COMANCHE

TURBOCHARGER LUBRICATION SYSTEM

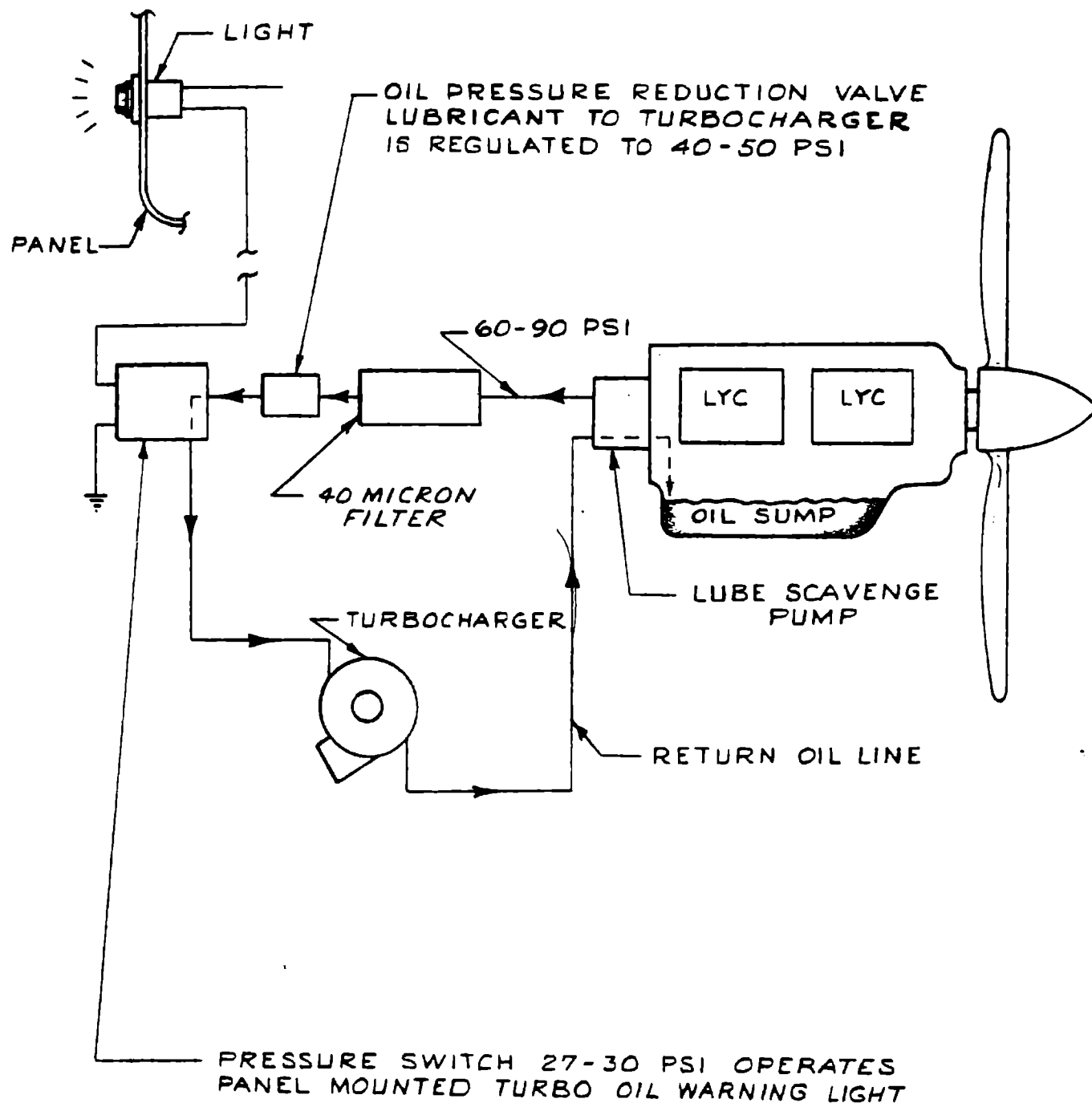

TURBOCHARGER WASTE GATE CONTROL SCHEMATIC

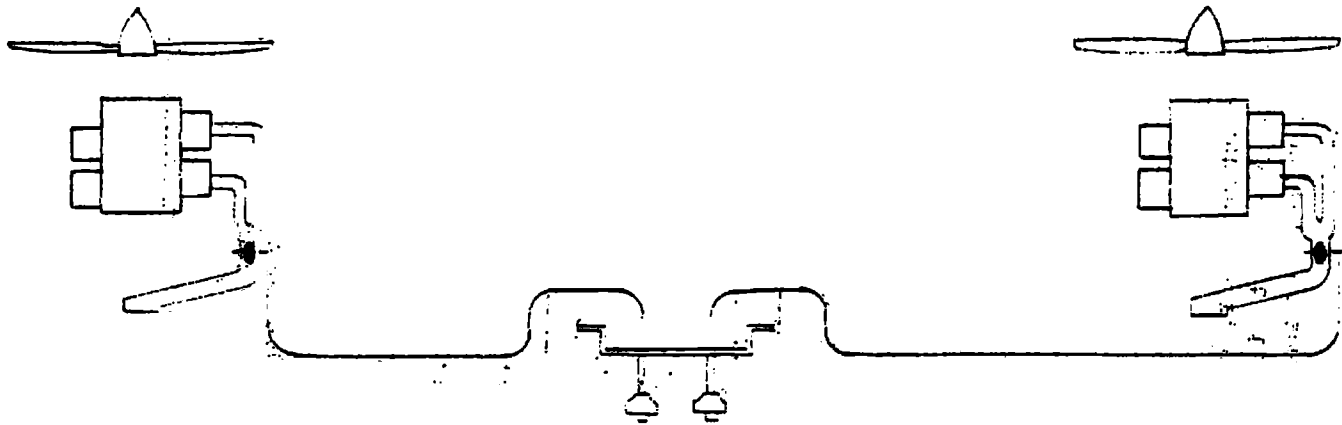

DUAL PUSH-PULL CONTROLS
WITH VERNIER ADJUSTMENT

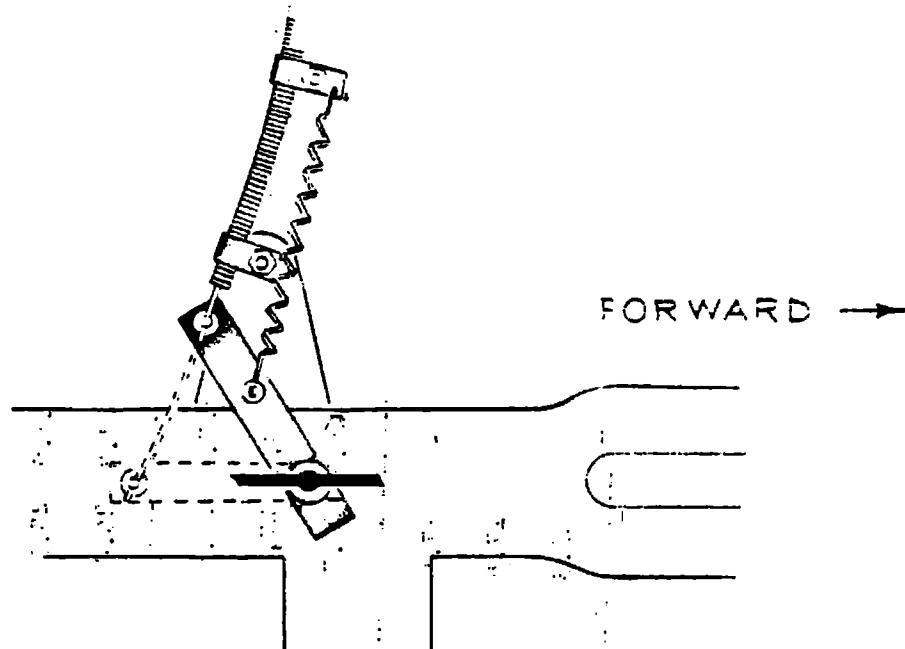

SOLID LINES REPRESENT NATURALLY ASPIRATED
WASTE GATE POSITION

BROKEN LINES REPRESENT TURBO-NORMALIZING
WASTE GATE POSITION

TURBO TWIN COMANCHE
Turbocharged Power Chart

Press. Alt. Feet	Std. Temp. °F	55% Power RPM and MAP		65% Power RPM and MAP			75% Power RPM and MAP		Press. Alt. Feet
		2200	2400	2200	2400	2600	2400	2600	
5,000	41	22.5	21.1	26.4	24.4	22.9	27.7	25.7	5,000
7,500	32	22.5	22.1	25.7	24.3	23.4	26.9	25.5	7,500
10,000	23	22.8	22.2	25.7	24.5	23.5	27.3	26.0	10,000
12,500	14	23.2	22.2	26.0	24.7	24.0	27.7	26.5	12,500
15,000	6	23.3	22.3	26.7	25.2	24.5	28.4	27.1	15,000
17,500	-4	23.6	22.6	27.3	25.5	24.5	28.7	27.7	17,500
20,000	-12	24.0	22.8	27.4	25.7	24.7	-	27.6	20,000
22,500	-21	24.4	23.0	-	26.0	24.7	-	27.6	22,500
25,000	-30	-	23.0	-	25.5	24.8	-	27.3	25,000

To Maintain constant power, correct manifold pressure approximately 0.25"Hg. for each 10°F variation in ambient air temperature from standard altitude temperature. Add manifold pressure for air temperatures above standard; subtract for air temperatures below standard.

TABLE OF CONTENTS

SERVICE

Page 1	Routine Service and Inspection
Page 1	1000 Hour Inspection
Page 2	Trouble Shooting in Flight or Ground Run-up
Page 6	Turbocharger Oil Flow Check
Page 7	Turbocharger Oil Filter Cleaning Procedure
Page 8	Fuel Nozzle Pressure Reference Assembly Installation

ROUTINE SERVICE AND INSPECTION

WHENEVER ROUTINE SERVICE OF THE ENGINE IS PERFORMED (25, 50 & 100 HOUR INSPECTIONS) INSPECT THE TURBOCHARGER INSTALLATION AS FOLLOWS:

1. Inspect all air inlet ducting and compressor discharge ducting for worn spots, loose clamps or leaks.
2. Inspect engine air inlet assembly for cracks, loose clamps and screws.
3. Inspect waste-gate housing, exhaust ducting and exhaust stacks for signs of leaks or cracks. Check all clamps for tightness.
4. Carefully check all Turbo support brackets, struts, etc. for breakage, sagging or wear.
5. Check all oil lines, fuel lines and fittings for wear, leakage heat damage or fatigue.
6. Actuate waste-gate control, check spring preload and examine control for any pending sign of breakage.
7. Inspect injector system for signs of fuel dye indicating leaks.
NOTE: If dye stains are present, check for loose connections and proper installation of air bleed nozzle shrouds.
8. Clean Turbocharger oil filter with solvent or gasoline every oil change. An overnight soaking in carburetor cleaner may be necessary if heavy sludging is evident. (This is usually due to mixing detergent with non-detergent oils.) For checking Turbocharger lubrication system, see illustration, page 6.
9. Run up engines, check all instruments for smooth, steady response.

1000 HOUR INSPECTION

1. Remove all Turbocharger components from the engine. Inspect and repair or replace as necessary. Check Turbocharger rotor for excessive play, carbon and dirt deposits. See trouble shooting section for rotor play limits. Remove turbine and compressor housings. Inspect turbine wheel and impeller for physical damage and excessive build up of deposits. If, excessive, replace Turbocharger assembly.

TROUBLE SHOOTING

TROUBLE IN FLIGHT OR GROUND RUN-UP	POSSIBLE CAUSE	FIX
<p>1. LOSS OF, REDUCTION OF, OR FLUCTUATION OF MANIFOLD PRESSURE, WHILE TURBOCHARGING</p>	<p>a. Malfunctioning manifold pressure gauge due to faulty gauge or possible oil in MAF reference line or gate.</p> <p>b. Turbocharger inlet duct blocked.</p> <p>c. Turbocompressor discharge duct ruptured or disconnected.</p> <p>d. Severe rupture on exhaust stacks causing waste-gate to be ineffective.</p> <p>e. Turbocharger rotor jammed.</p> <p>f. Ruptured manifold gauge line or ftg.</p> <p>g. Broken waste-gate control</p> <p>h. Air inlet check valve not fully sealing or blocked partly open.</p>	<p>a. Repair or replace gauge. NOTE: If the engine changes in power level or the airspeed changes, then actual change in MAP has occurred due to one of the reasons listed below:</p> <p>b. Check ducting and remove obstruction.</p> <p>c. Connect or replace ducting.</p> <p>d. Replace defective part.</p> <p>e. Replace Turbocharger.</p> <p>f. Repair leak.</p> <p>g. Replace control cable.</p> <p>h. Inspect, repair or replace as needed.</p>
<p>2. LOSS OR REDUCTION OF FUEL PRESSURE WHEN TURBOCHARGING</p>	<p>a. Out of fuel.</p> <p>b. Partial fuel vapor lock at high altitude due to hot fuel and high power settings.</p> <p>c. Malfunctioning fuel pressure regulating valve or fuel pump.</p> <p>d. Ruptured fuel line or leaking ftg. or pump shaft seal.</p>	<p>a. Refuel</p> <p>b. Turn on boost pump and/or reduce power.</p> <p>c. Turn on boost pump and/or reduce power.</p> <p>d. Shut off fuel shut-off valve, full rich mixture until fuel fwd of firewall is consumed by engine. Secure engine.</p>

TROUBLE SHOOTING

TROUBLE IN FLIGHT OR GROUND RUN-UP	POSSIBLE CAUSE	FIX
2. LOSS OR REDUCTION OF FUEL PRESSURE WHEN TURBOCHARGING (con't)	e. Ruptured boost pressure reference line to fuel pressure regulating valve.	e. Continue operation until next landing if engine is smooth; otherwise, return engine to naturally as- pirated power. Ground check fuel system.
3. TURBOCHARGER OIL PRESSURE WARNING LIGHT ON	<p>a. Low engine speed: i.e. idle RPM.</p> <p>b. Low engine oil pressure.</p> <p>c. Clogged Turbocharger oil filter.</p> <p>d. Shorted oil pressure warning switch.</p> <p>e. Ruptured Turbocharger oil supply line or leaking fitting.</p>	<p>a. This is normal</p> <p>b. Take necessary measures to restore engine oil pressure.</p> <p>c. Clean and replace Turbo charger oil filter. (See illustration, Page <u>7</u>) NOTE: Clogging can occur very rapidly if detergent and non-detergent oils are mixed indiscriminately.</p> <p>d. Replace switch.</p> <p>e. Replace oil supply line. Tighten or replace faulty fitting.</p>
4. ENGINE RUNS HOT (500° OR MORE) WHEN TURBOCHARGING OR NATURALLY ASPIRATED.	<p>a. May be due to extreme hot weather.</p> <p>b. Cracked or loose cylinder cooling air baffles.</p> <p>c. During climb.</p> <p>d. Over-boost or RPM too high.</p> <p>e. Fuel mixture too lean during very hot weather.</p>	<p>a. Reduce power.</p> <p>b. Repair or replace as re- quired.</p> <p>c. Reduce power or increase Indicated Air Speed.</p> <p>d. Reduce MAP or RPM</p> <p>e. Enrichen mixture.</p>

TROUBLE SHOOTING

TROUBLE IN FLIGHT OR GROUND RUN-UP	POSSIBLE CAUSES	FIX
<p>4. ENGINE RUNS HOT (500° OR MORE) WHEN TURBOCHARGING OR NATURALLY ASPIRATED (con't)</p>	<p>f. Mis-timed ignition, either retarded or pre-ignition.</p> <p>g. Detonation due to too low octane fuel or item "f" above.</p> <p>h. Faulty cylinder head temperature gauge.</p> <p>i. Defective oil cooling system.</p> <p>j. Combinations of above.</p>	<p>f. Check ignition timing, adjust as necessary.</p> <p>g. Fuel mixture set too lean or fuel octane too low. Check mixture and fuel grade.</p> <p>h. Replace instrument.</p> <p>i. Inspect and repair as required.</p> <p>j. Systematically eliminate by above steps.</p>
<p>5. AIRPLANE PERFORMANCE IS REDUCED FROM NORMAL</p>	<p>a. May be due to hot weather.</p> <p>b. Tired engine, or out of tune</p> <p>c. Airplane may have additional drag due to radio antenna, sagging flaps, out of rig, etc.</p>	<p>a. Turbo aircraft speed will be reduced 2 to 4 mph for 10°F rise in temperature above standard day. This is because Turbochargers, like turbines, are heat sensitive as to performance.</p> <p>b. Repair engine as required.</p> <p>c. Inspect airframe and repair as necessary.</p>
<p>6. FUEL CONSUMPTION IS HIGHER THAN NORMAL</p>	<p>a. Mixture set too rich.</p> <p>b. Leak in fuel system.</p> <p>c. Prolonged high power at full rich mixture,</p>	<p>a. Develop proper leaning technique.</p> <p>b. Locate and repair leak.</p> <p>c. Reduce power and lean for fuel economy.</p>

TROUBLE SHOOTING

TROUBLE IN FLIGHT OR GROUND RUN-UP	POSSIBLE CAUSE	FIX
<p>6. FUEL CONSUMPTION IS HIGHER THAN NORMAL (con't)</p>	<p>d. Hot weather</p>	<p>d. Hot weather will naturally increase fuel consumption 2 to 4 CPH depending on power, leaning and temperature of the air. This is due to less dense air for the same MAP. Also it has been found from tests that slightly richer mixture should be used for extremely warm weather to maintain a lower head temperature. This will insure good engine life.</p>
<p>1. OIL LEAKING OUT OF ENGINE INLET DRAIN NOTE: CARE SHOULD BE TAKEN TO MAKE SURE OIL IS FROM INSIDE ENGINE INLET DRAIN, NOT ON THE OUTSIDE FROM SOME OTHER POINT ON ENGINE</p>	<p>a. Oil sump or intake guide leaking into induction system.</p> <p>b. Failed Turbocharger bearings and compressor seal.</p> <p>c. Turbocharger drain line misrouted or plugged.</p>	<p>a. Repair or replace sump or valve guide.</p> <p>b. Replace Turbocharger. NOTE The Turbocharger seal will have to be in <u>very</u> poor condition to permit oil to pass the <u>compressor</u> impeller seal.</p> <p>c. Re-route for clear flow or remove obstruction from line.</p>
<p>2. NOISY TURBOCHARGER ROTATING ASSEMBLY</p>	<p>a. Damaged bearings.</p> <p>b. Rotating unit rubbing housing as a result of "a" above, distorted housings, dirt accumulation on impeller, carbon build-up on turbine or foreign object damage.</p>	<p>a. Replace unit.</p> <p>b. Replace unit. NOTE: Allowable shaft radial play is .017 to .028 inch due to semi-floating bearings. Allowable shaft axial play is .004 to .009 inch.</p>

TURBO TWIN COMANCHE

TURBO OIL FLOW CHECK

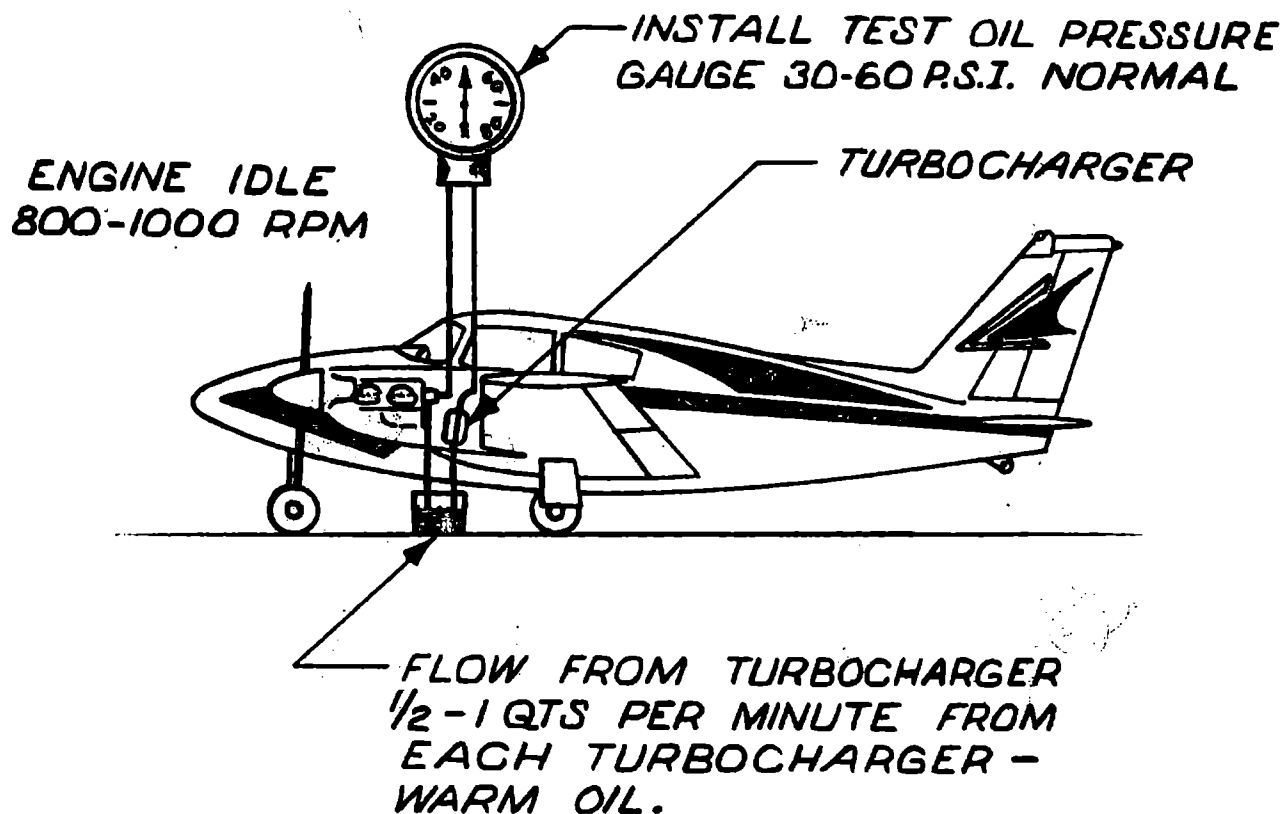

1. UNFASTEN TURBO OIL RETURN HOSE AT TURBO END.
2. RUN TEST HOSE FROM SCAVENGE LINE TO TEST TANK.
3. RUN TEST HOSE FROM TURBO DRAIN PORT TO TEST TANK.
4. PLACE PRESSURE GAUGE IN OIL LINE AT TURBO OIL INLET CONNECTION.
5. RUN TEST.

TURBO OIL FILTER CLEANING PROCEDURE

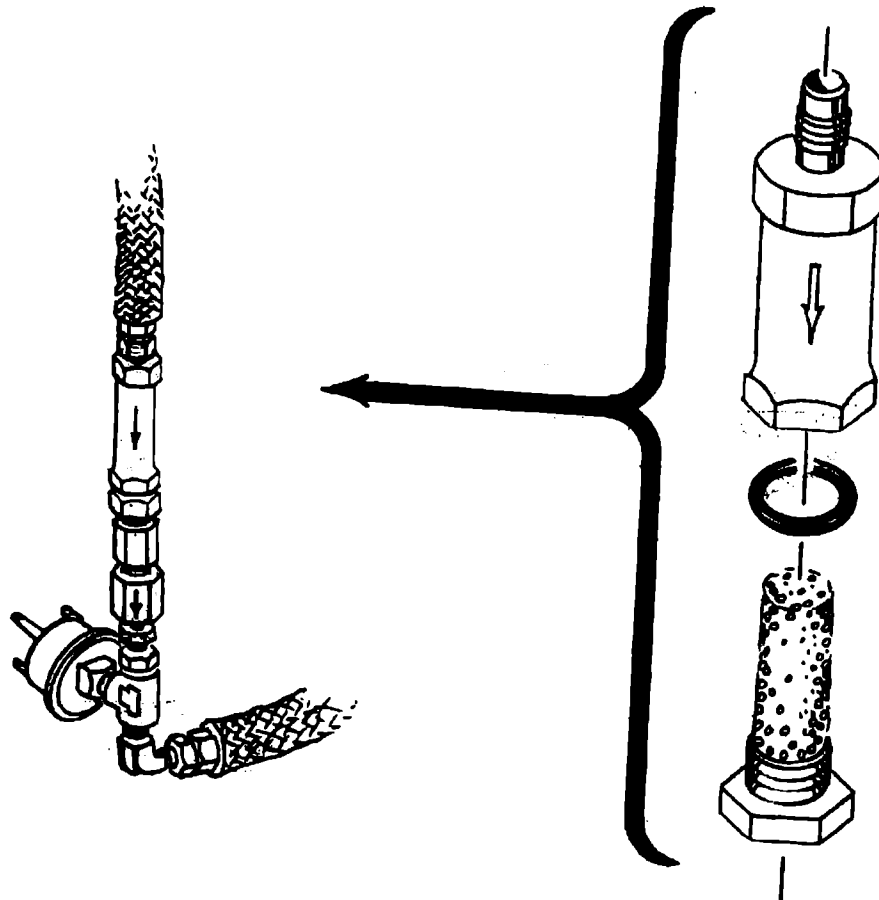

REMOVE OIL FILTER FROM LINE AND
DISSASSEMBLE UNIT. WASH PARTS
WITH SOLVENT AND BACK FLUSH THE
BRONZE ELEMENT. CHECK CONDITION
OF "O" RING AND REPLACE IF NECESSARY.
REASSEMBLE UNIT AND INSTALL FILTER
IN THE TURBO OIL SYSTEM. CLEAN
FILTER AT EACH OIL CHANGE.

FUEL NOZZLE PRESSURE REFERENCE ASSEMBLY INSTALLATION

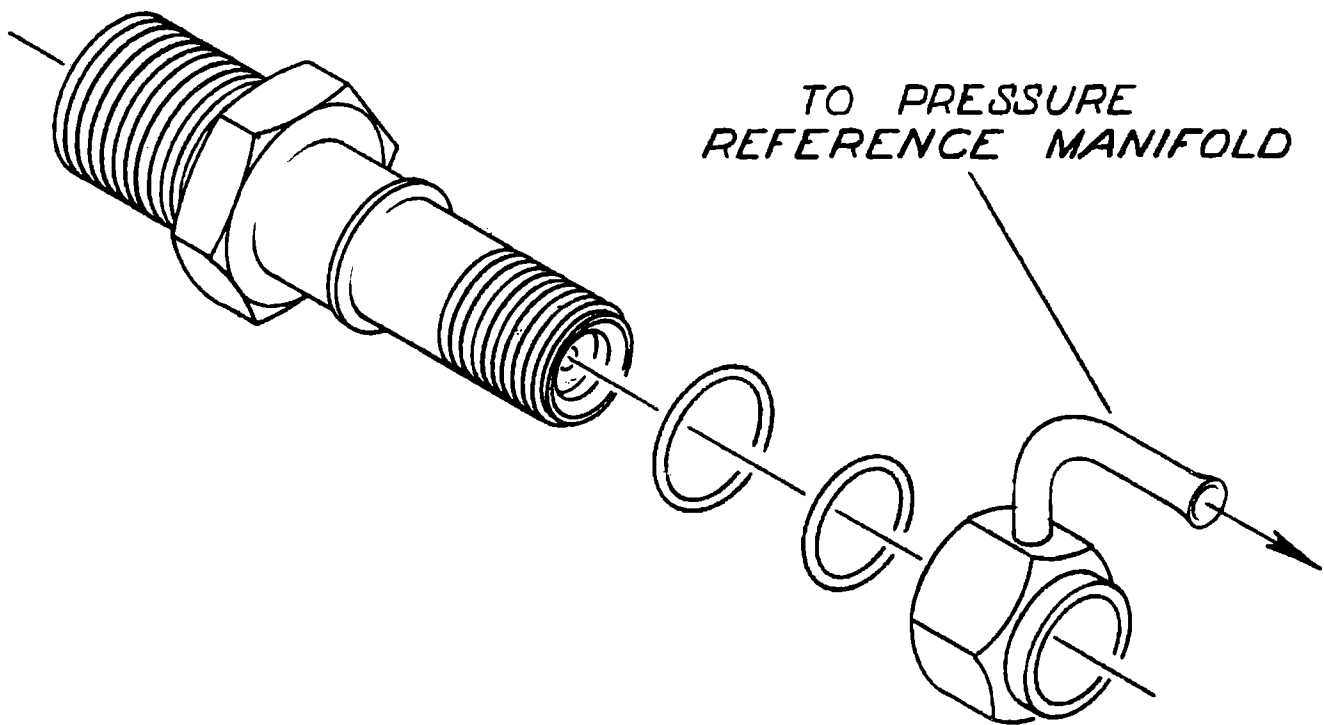

*INSTALL 'O' RINGS AND SHROUD
ON EXISTING NOZZLE AS SHOWN*

THIS PAGE LEFT BLANK

T U R B O T W I N C O M A N C H E P A - 3 0

I l l u s t r a t e d P a r t s S e c t i o n

<u>Page</u>	<u>FIG.</u>	<u>Assembly</u>
1	I	Engine Air Inlet System
3	II	Engine Air Inlet Filter Assy
5	III	Alternate Air Inlet Valve Assy
7	IV	Engine Exhaust System
9	V	T/C Exhaust System
11	VI	Turbocharger Mount System
13	VII	Turbocharger Control System
15	VIII	Control Brackets
17	IX	Turbocharger Lubrication System
19	X	Engine Oil Cooler
21	XI	Pressure Reference System
23	XII	Nacelle Parts
25	XIII	Turbocharger Scavenge System

TURBO TWIN COMANCHE

I Engine Air Inlet System

Item No.	Part Number	No. Req.		Part Name
		Per	A/C	
I-1	RJ 0617-3		2	Scoop
2	RJ 0617-5		2	Plate
3	RJ 0621-9		2	Sealing Strip
4	AN470A4-4		46	Rivet
5	AN960-4L		50	Washer
6	RJ 0606		2	Compressor Discharge Box Assy
7	AN960-6L		16	Washer
8	LL22D62-P8x2		16	Screw
9	AN737-TW-82		4	Clamp
10	FTW-779		2	Flex Duct
11	AN737TW-91		4	Clamp
12	APS1101-3"x8½"		2	Flex Duct
13	NAS183-4-8A		8	Stud
14	½IDx5/16ODx3/8		8	Spacer
15	505		8	Grommet
16	AN960-416		24	Washer
17	AN365-428		8	Nut
18	APS1103-2½"x5½"		2	Flex Duct
19	AN426A4-4		4	Rivet
20	AN3-4A		4	Bolt
21	AN960-10		4	Washer
22	AN737TW107		4	Clamp
23	AN366F-1032		4	Nutplate
24	AN426A3-4		8	Rivet
25	RJ 0621-3		2	Sealing Strip
26	RJ 0621-5		2	Sealing Strip
27	RJ 0621-7		2	Sealing Strip

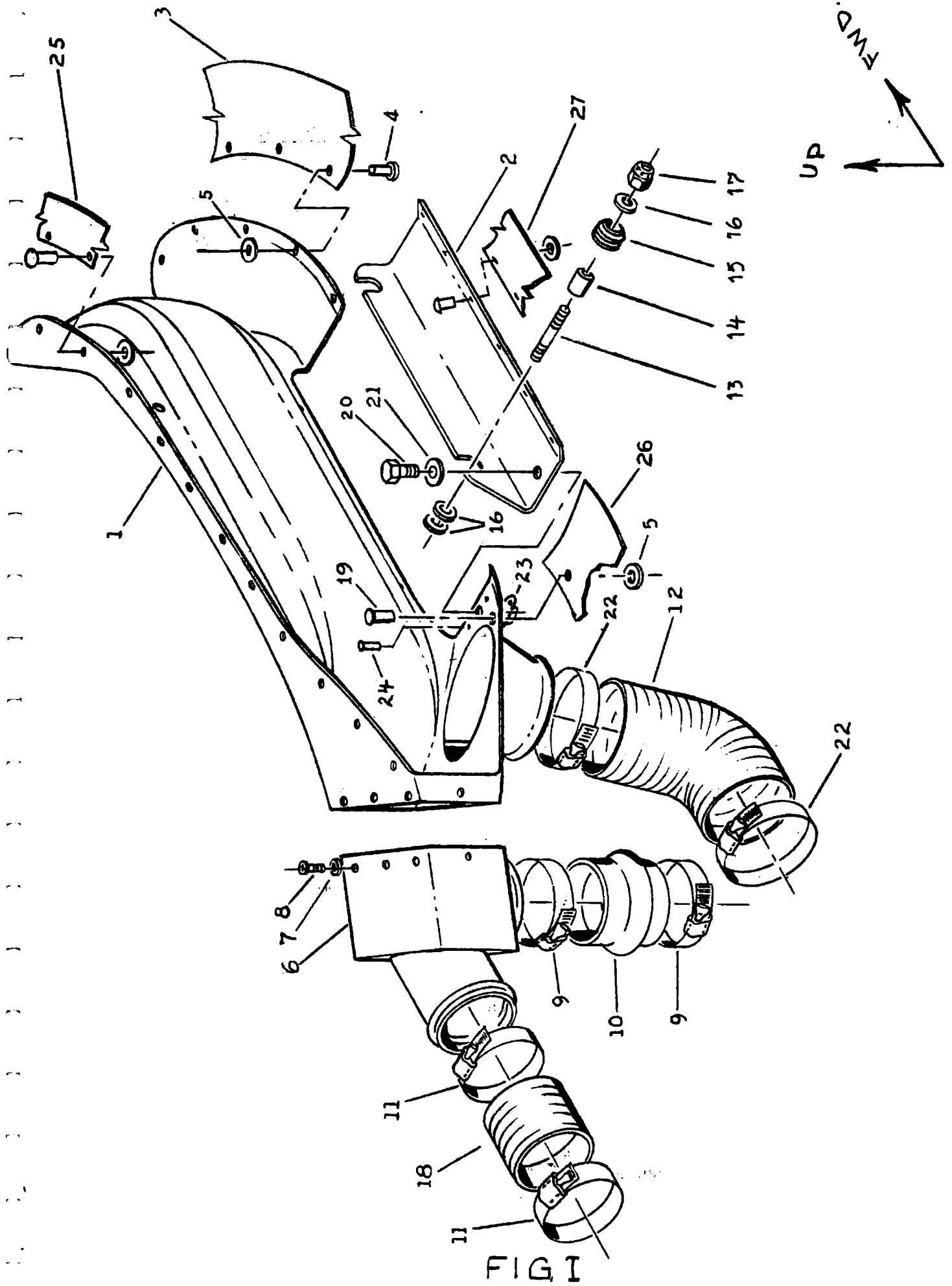

FIG 1

TURBO TWIN COMANCHE

II Engine Air Inlet Filter Assy

<u>Item No.</u>	<u>Part Number</u>	<u>No. Reqd. per A/C</u>	<u>Part Name</u>
II-1	RJ 0605-31	1	Valve Assy
2	RJ 0605-21	1	Can Assy
3	RJ 0605-27	1	Seal
4	$\frac{1}{4}$ -20	6	Wing Nut
5	AN960-416	6	Washer
6	RJ 0605-33	2	Cap
7	AN74A5	6	Bolt
8	RJ 0605-51	6	Rod Assy
9	AN936A416	6	Washer
10	WWD-128	4	Clamp Assy
11	APS 800 <i>APS800/HBS</i>	2	Flex Duct
12	RJ 0607	2	Elbow
13	201485	2	Filter
14	AN3-4A	8	Bolt
15	AN970-3	8	Washer
16	AN365-1032	8	Nut
17	RJ 0522	2	Gasket
*18	RJ 0718-2	1	Elbow
*19	RJ 0718-4	1	Tee
20	RJ 0628	2	Asbestos Strip
21	AN970-4	6	Washer

Sold only as an
Assy, 2 reqd. per
A/C

*Used only with fuel pressure gauge

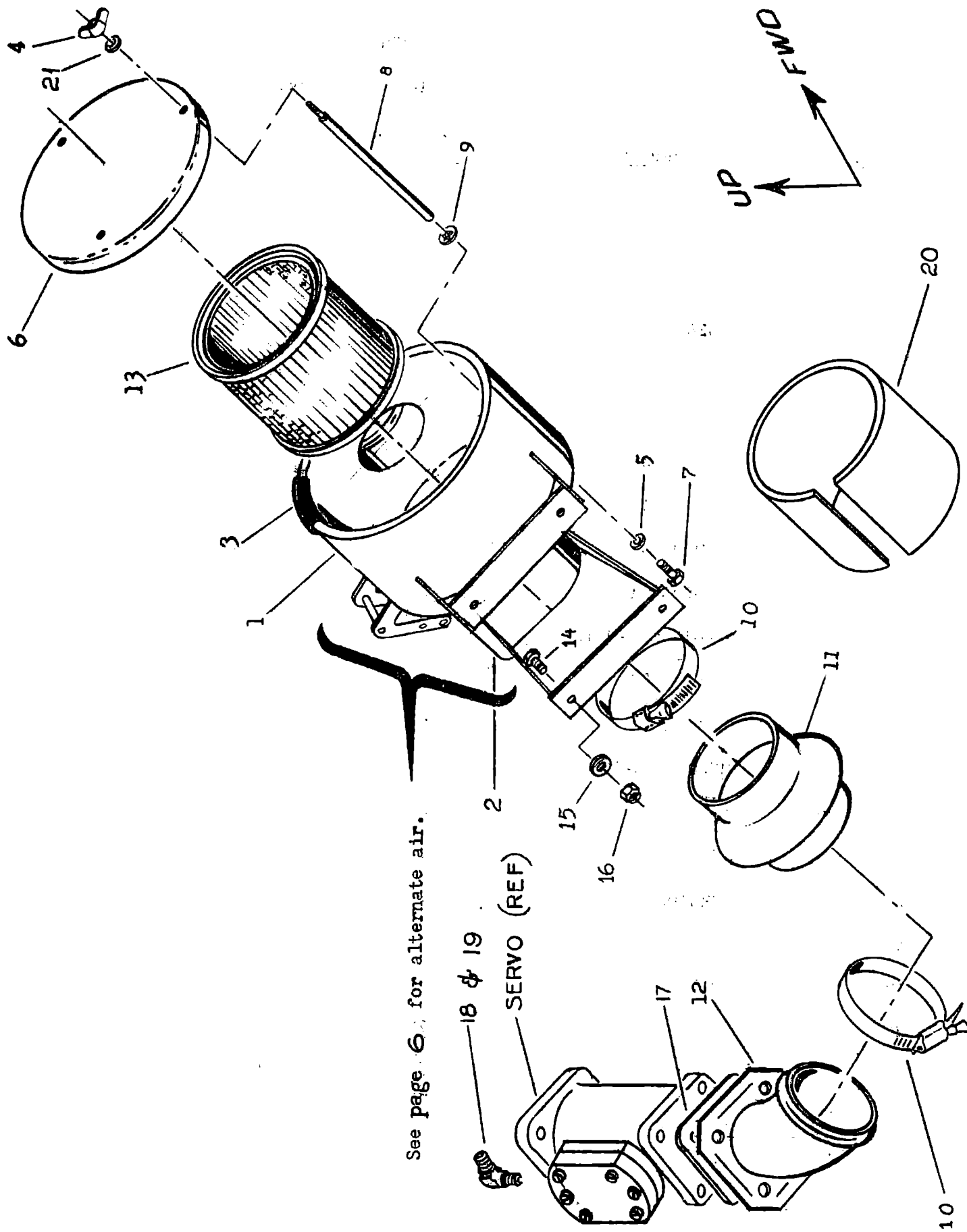

See page 6 for alternate air.

FIG. II

TURBO TWIN COMANCHE

III Alternate Air Inlet Valve Assy

<u>Item No.</u>	<u>Part Number</u>	<u>No. Reqd. Per A/C</u>	<u>Part Name</u>
III-1	LP22D62P4x2	12	Screw
2	RJ 0605-17	1	Frame } Sold only as an Assy 2 reqd. per A/C
3	RJ 1005	1	
4	AN526-6R6	4	Screw
5	RJ 0605-7	2	Bracket
6	AN960-6	4	Washer
7	AN365-632	4	Nut
8	RJ 0605-11	2	Arm Assy
9	RJ 0605-41	2	Arm Assy
10	RJ 0605-61	2	Rod Assy
11	59-012-062-0312	4	Roll Pin
12	RJ 0605-71	1	Bracket } Sold only as an Assy 2 reqd. per A/C
13	RJ 0605-5	1	
14	MS20392-2-49	2	Pin
15	AN381-2-15	2	Cotter Pin
16	AN380-2-8	2	Cotter Pin
17	CSR51029	2	Spring
18	RJ 0605-55	2	Rubber Pad
19	70371-03	2	Pin (Existing)
20	70371-02	2	Bushing (Existing)
21	AN310-3	2	Nut (Existing)

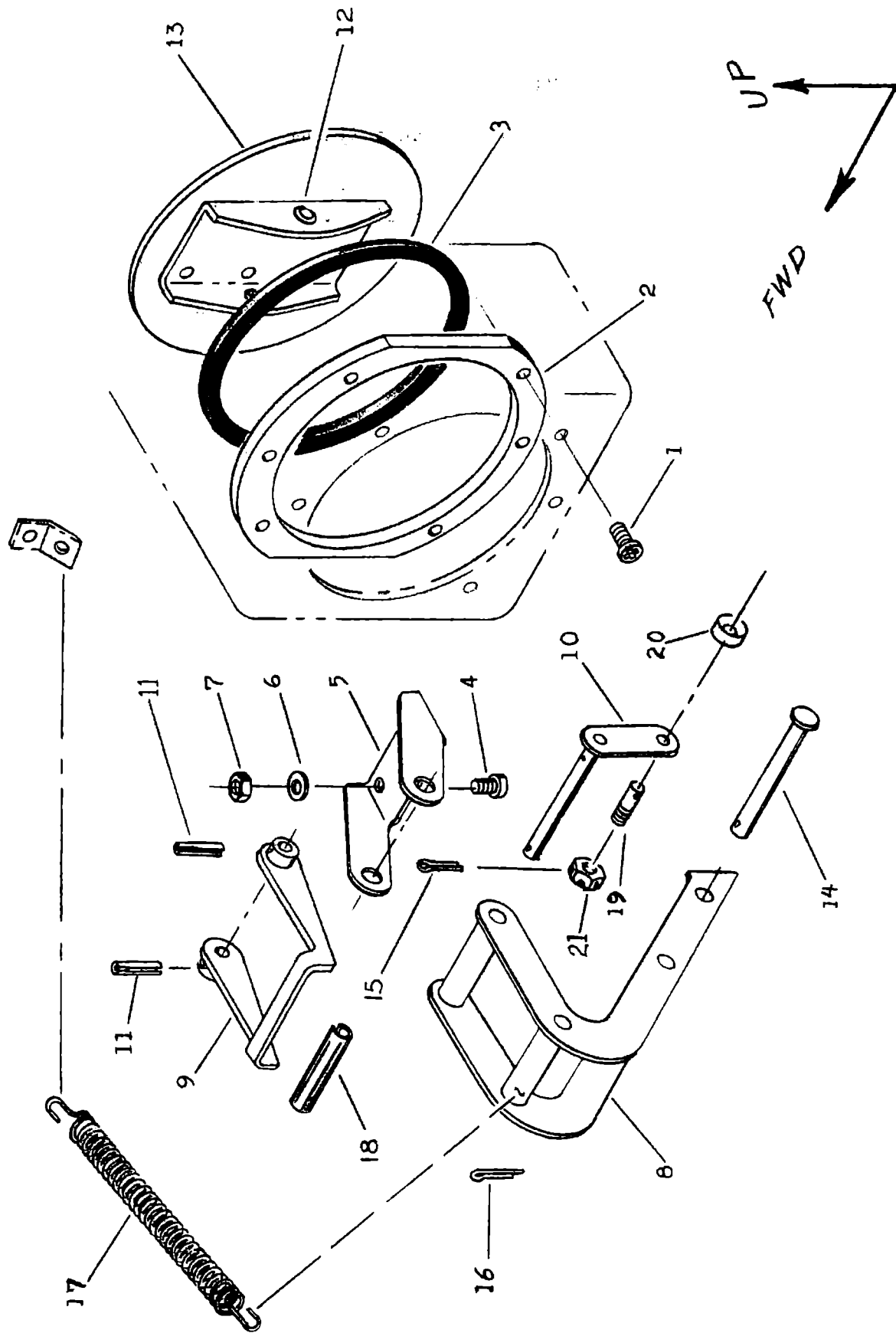

FIG. III

TURBO TWIN COMANCHE

IV Engine Exhaust System

<u>Item No.</u>	<u>Part Number</u>	<u>No. Reqd. Per A/C</u>	<u>Part Name</u>
IV-1	23850-10	2	Exhaust Stack (Piper)
2	RJ 0602-■ 4/	2	Exhaust Stack
3	RJ 0602-■ 5/	2	Exhaust Stack
4	RJ 0602-■ 6/	2	Exhaust Stack
5	65321	8	Gasket

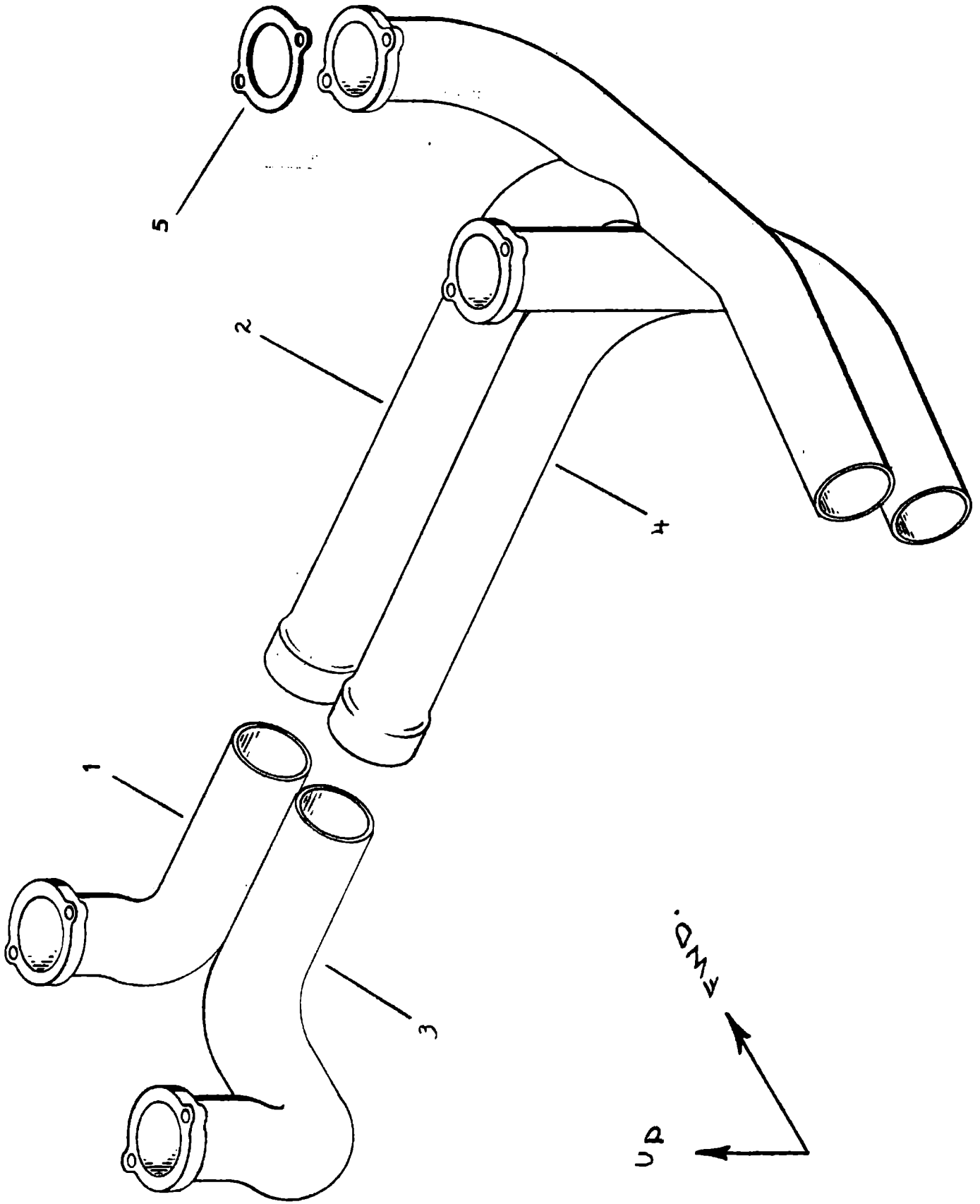

FIG IV

TURBO TWIN COMANCHE

V Turbocharger Exhaust System

<u>Item No.</u>	<u>Part Number</u>	<u>No. Reqd. per A/C</u>	<u>Part Name</u>
V-1	RJ 0603-11	1	Waste Gate Body
2	RJ 0050	1	Butterfly
3	RJ 0057	1	Shaft
4	RJ 0055	1	Plug
5	RJ 0053	1	Ring
6	1-S-062-0562	1	Roll Pin
7	AN381-4-16	2	Cotter Pin
8	RJ 0048-501	2	Control Arm
9	AN363-632	2	Nut
10	NAS43-1-32	2	Spacer
11	AN960-6L	2	Washer
12	AN526-6R14	2	Screw
13	RJ 0115	2	Gasket
14	RJ 0114	2	Gasket
15	40030-369-M-G	4	Clamp
16	RJ 0604	2	T/C Exhaust Stack
17	H-170	A/R	Heat-Rem Paint

Sold only as
an Assy
2 reqd. per A/C

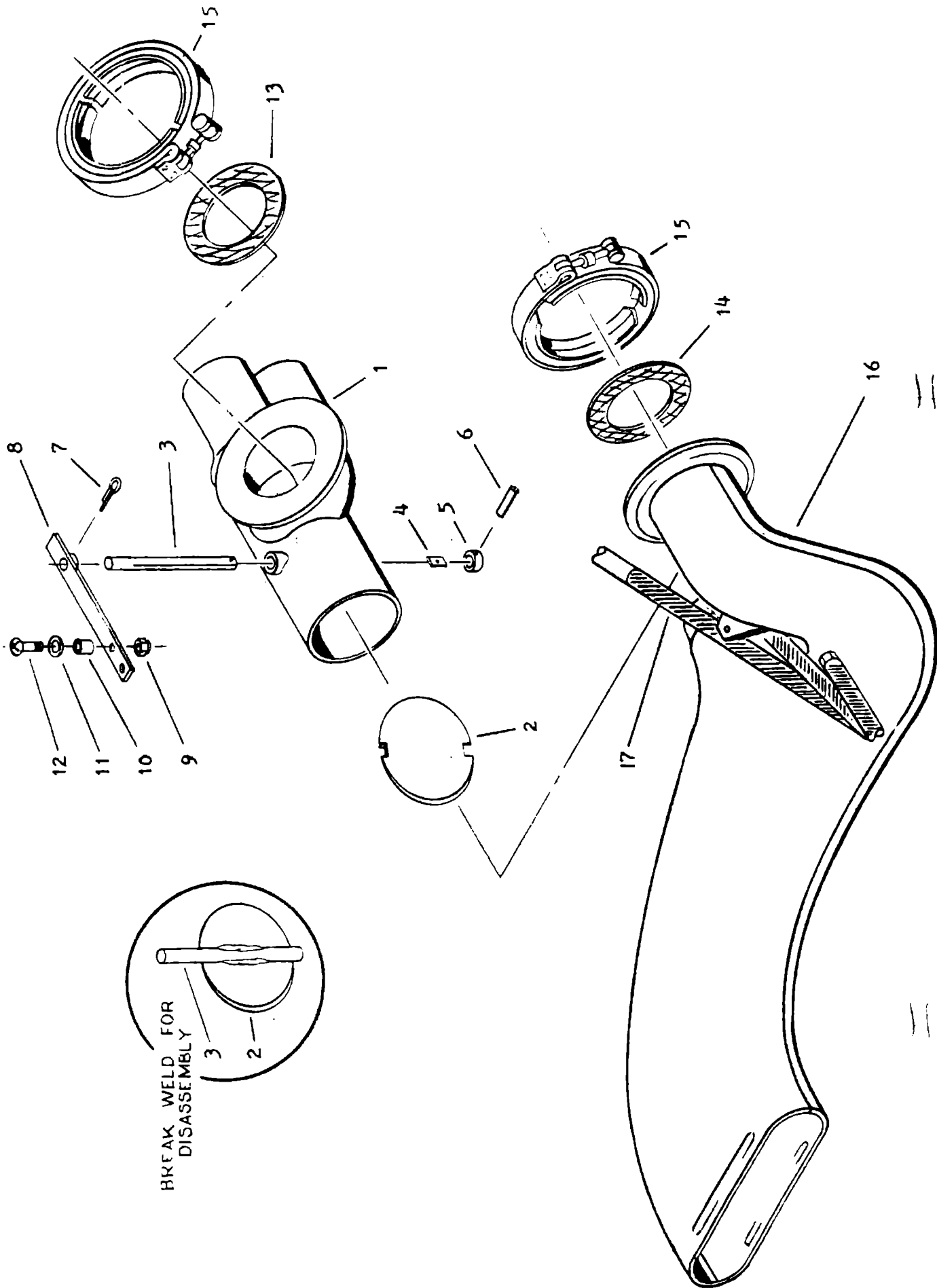

BREAK WELD FOR
DISASSEMBLY

FIG V

TURBO TWIN COMANCHE

VI Turbocharger Mount System

<u>Item No.</u>	<u>Part Number</u>	<u>No. Reqd. Per A/C</u>	<u>Part Name</u>
VI-1	325H10	2	Turbocharger
2	RJ 0612-21	2	Bracket
3	AN5-27A	2	Bolt
4	AN960-516	10	Washer
5	AN363-524	4	Nut
6	RJ 0612-41	2	Bracket
7	AN5-11A	2	Bolt
8	RJ 0612-31	2	Zee Bracket
9	AN960-10	4	Washer
10	AN363-1032	4	Nut
11	RJ 0612-11	2	Bracket
12	AN3-4A	4	Bolt
13	AN4-11A	2	Bolt
14	AN960-416	8	Washer
15	AN363-428	2	Nut
16	AN960-416L	4	Washer
17	AN936A416H	2	Washer
18	NAS43-5- X 88	2	Spacer

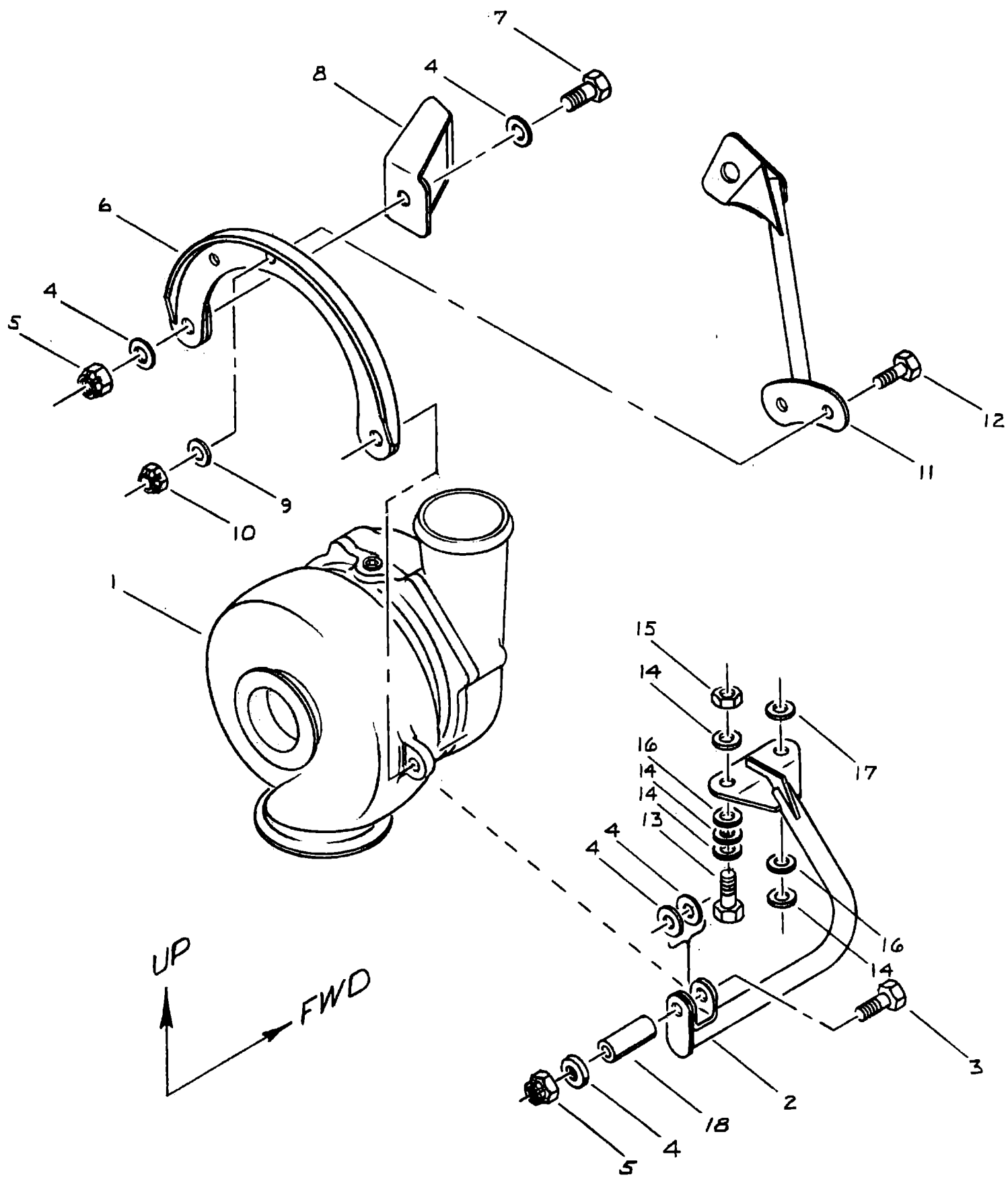

FIG VI

TURBO TWIN COMANCHE

VII Turbocharger Control System

<u>Item No.</u>	<u>Part Number</u>	<u>No. Req'd Per A/C</u>	<u>Part Name</u>
VII-1	345-006	2	Control Assy
2	RJ 1008-1	1	Placard - T/C Control
3	RJ 0609	1	T/C Control Panel
4	AN3-4A	4	Bolt
5	RJ 0620	1	Fuel Flow Guage
6	AN365-1032	8	Nut
7	MT 340	2	Grommet Holder
8	MT840x $\frac{1}{2}$ D	2	Grommet
9	RJ 0131	1	Placard - Wide Open Throttle
10	RJ 2015-1	1	Placard - Circuit Breaker
11	A200-1-2	1	Connector
12	RJ 0610-5	1	Placard - Boost Pump
13	759 SS-3	2	Clamp
14	AN526-6R14	2	Screw
15	AN960-10	12	Washer
16	AN363-632	2	Nut
17	70371-03	2	Pin
18	70371-02	2	Bushing
19	AN310-3	4	Nut
20	AN381-2-16	4	Cotter Pin
21	#108	2	Spring
22	RJ 2015-3	1	Placard - 25,000 Feet
23	RJ 1008-11	1	Placard - Oxygen
24	RJ 0610-3	1	Placard - Descent
25	RJ 0610-1	1	Placard - T/C Operation
26	AN3-4	2	Bolt
27	RJ 0133	1	Placard - T/C Oil Warning
28	855S1-R-9-D	2	Light Assy
29	#330	2	Bulb - 12 Volt
30	AN960-6L	2	Washer
31	NAS43-1-32	2	Spacer
32	AN526-10R8	4	Spacer
33	22105-03	2	Gasket
34	AN816-2D	3	Nipple
35	AN931-4-7	2	Grommet
36	759S-3	2	Clamp
37	Type 02	1	Alt. Fuel Pressure Gauge
38	A8944-632-24J	4	Inst. Clip
39	RJ 0610-7	1	Placard - RPM
40	RJ 0610-9	4	Placard - Fuel Cap
41	RJ 0610-13	1	Placard - Speed Limit

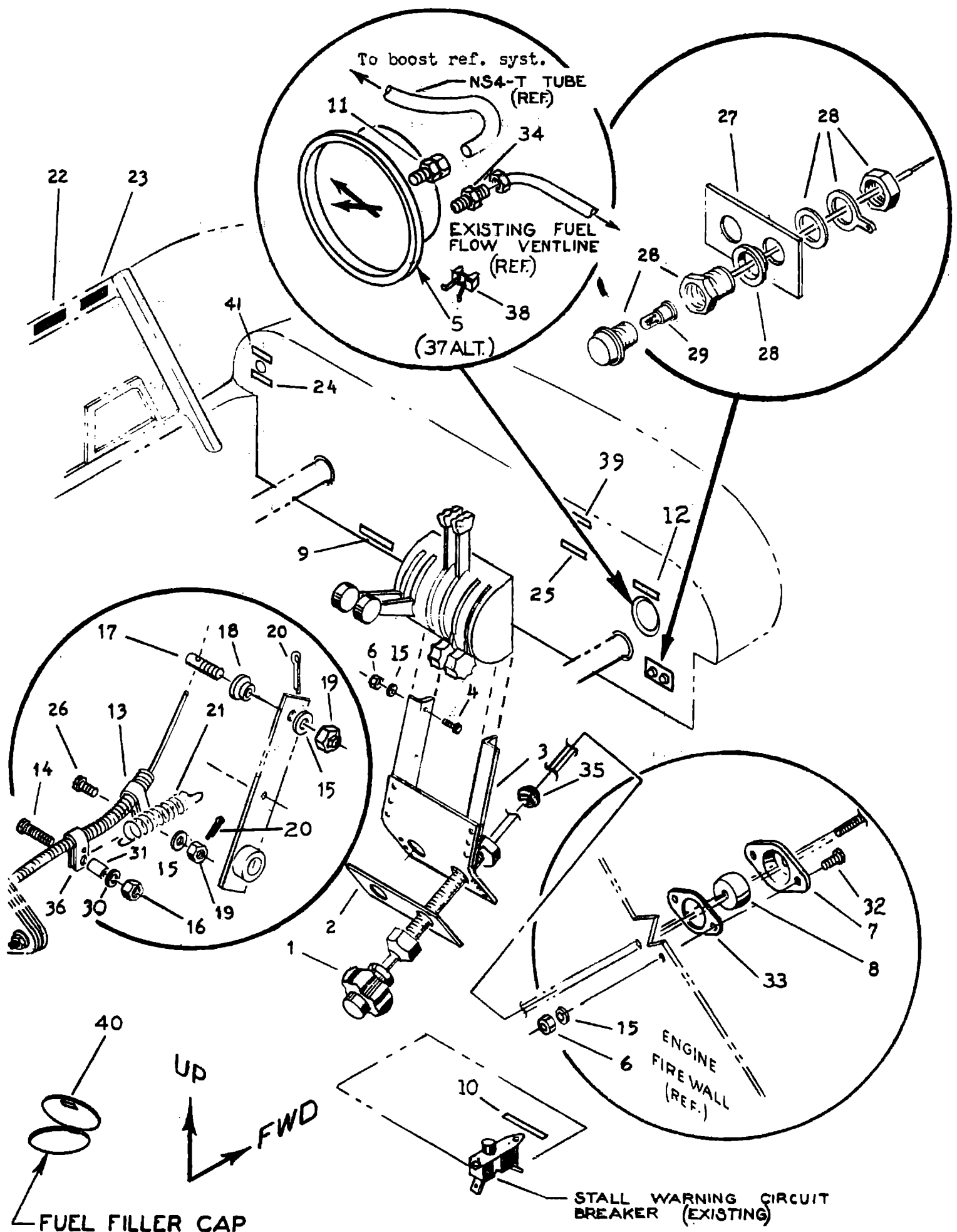

FIG VII

TURBO TWIN COMANCHE

VIII Control Brackets

<u>Item No.</u>	<u>Part Number</u>	<u>No. Reqd. Per A/C</u>	<u>Part Name</u>
VIII-1	RJ 0611-21	2	Prop. Gov. Control Bracket
2	RJ 0616	2	Mixture Control Bracket
3	RJ 0613	2	Throttle Control Bracket
4	AN515-8R 9	12	Screw (Existing)
5	AN960-8	12	Washer (Existing)
6	AN363-832	12	Nut (Existing)
7	18219-02	6	Clamp (Existing)
8	759S-7	2	Clamp
9	AN526-8R 10	2	Screw
10	AN960-8	2	Washer
11	AN365-832	2	Nut
12	RJ 0611-5	2	Tube
13	RJ 0611-15	2	Tube

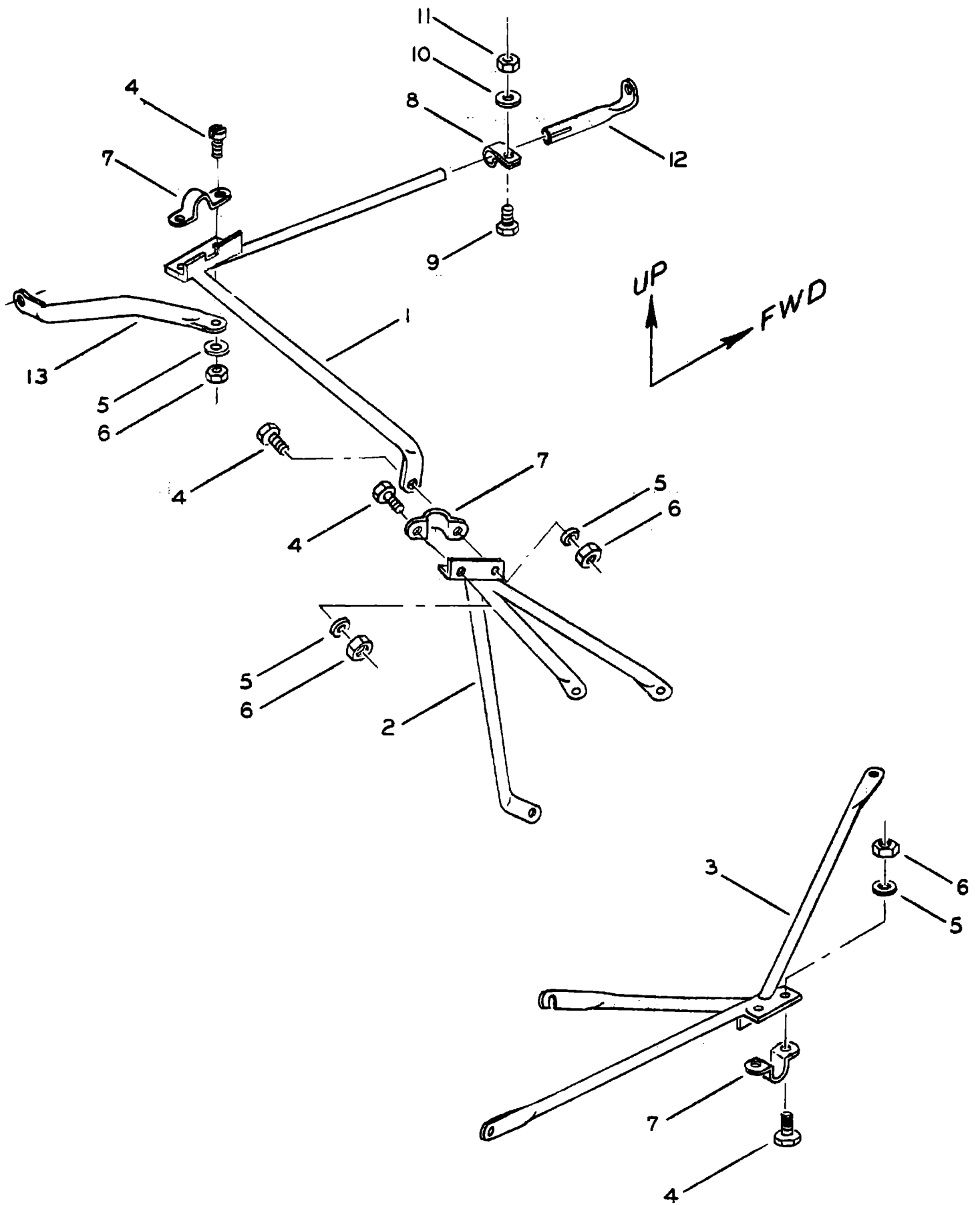

FIG VIII

TURBO TWIN COMANCHE

IX Turbocharger Lubrication System

<u>Item No.</u>	<u>Part Number</u>	<u>No. Reqd. Per A/C</u>	<u>Part Name</u>
IX-1	RJ 0623-2	2	Bolt
2	624000-4-0360	2	Hose Assy
3	AN900-10	4	Crush Washer
4	03-20233A-40	2	Filter
5	AN6227-7	2	"O" Ring
6	4-4GTX-D	2	Connector
7	559-A-2MP-30	2	Check Valve
8	AN742-14C	2	Clamp
9	AN742-10C	2	Clamp
10	AN526-10R8	4	Screw
11	AN960-10	4	Washer
12	AN911-1C	2	Nipple
13	A10-75	4	Rivnut
14	AN912-1D	2	Bushing
15	AN911-1D	2	Nipple
16	AN917-1D	2	Tee
17	M1-1540	2	Pressure Switch
18	AN822-4D	2	Elbow
19	624000-4-0224	2	Hose Assy
20	RJ 0623-1	2	Elbow
21	4GTX-D AN823-4	2	Elbow
22.	RJ 0630	2	Clamp

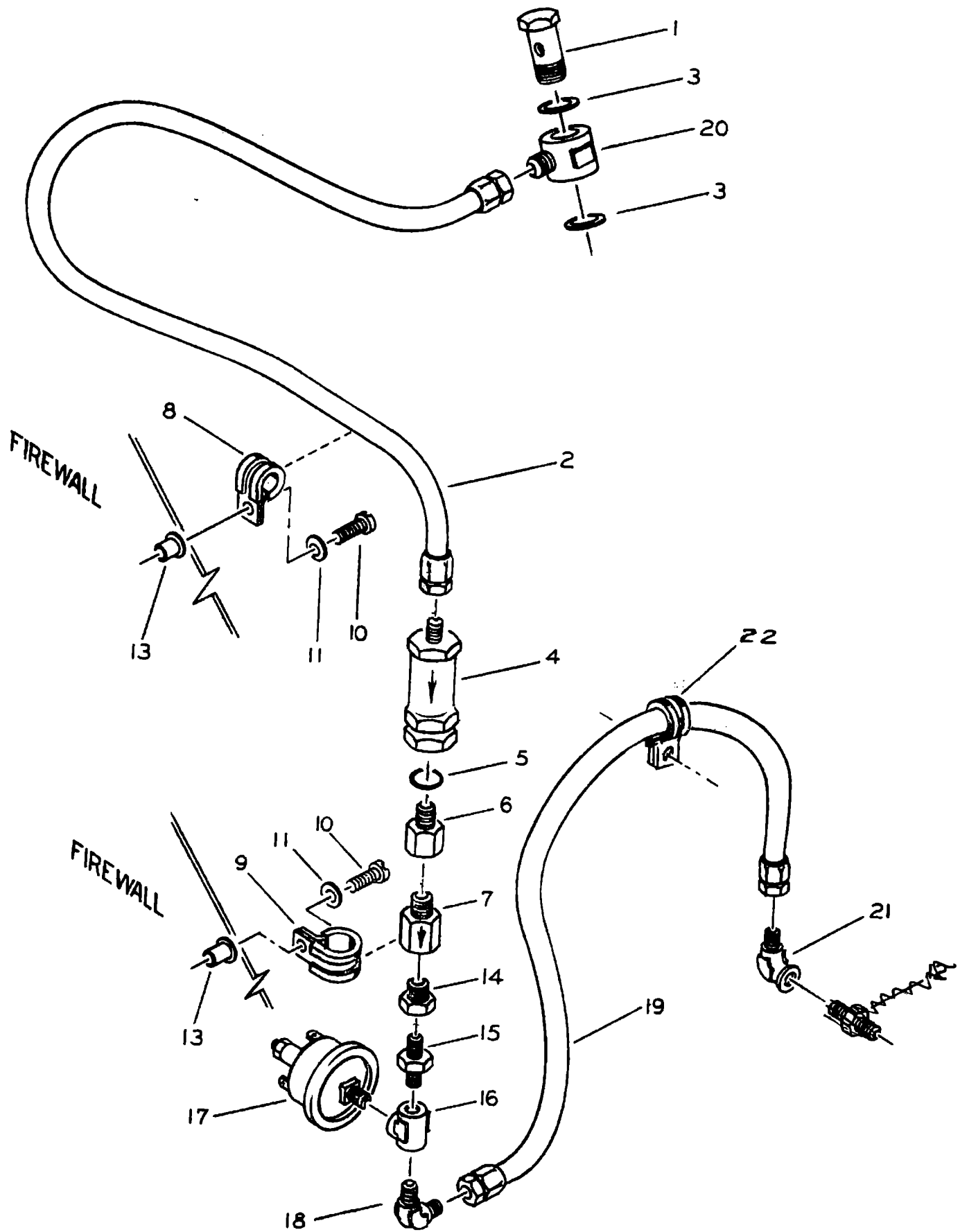

FIG IX

TURBO TWIN COMANCHE

X Engine Oil Cooler

<u>Item No.</u>	<u>Part Number</u>	<u>No. Reqd. Per A/C</u>	<u>Part Name</u>
X-1	AN526-8R10	2	Screw
2	AN960-8	6	Washer
3	AN365-832	6	Nut
4	NAS43-3-16	2	Spacer
5	624000-6-0136	2	Hose Assy
6	624000-6-0170	2	Hose Assy
7	AN822-6-6D	2	Elbow
8	FJ 0624	2	Duct - Oil Cooler
9	8534108	2	Oil Cooler
10	AN526-6R8	18	Screw
11	AN960-6	18	Washer
12	AN365-632	18	Nut
13	AN526-8R8	4	Screw

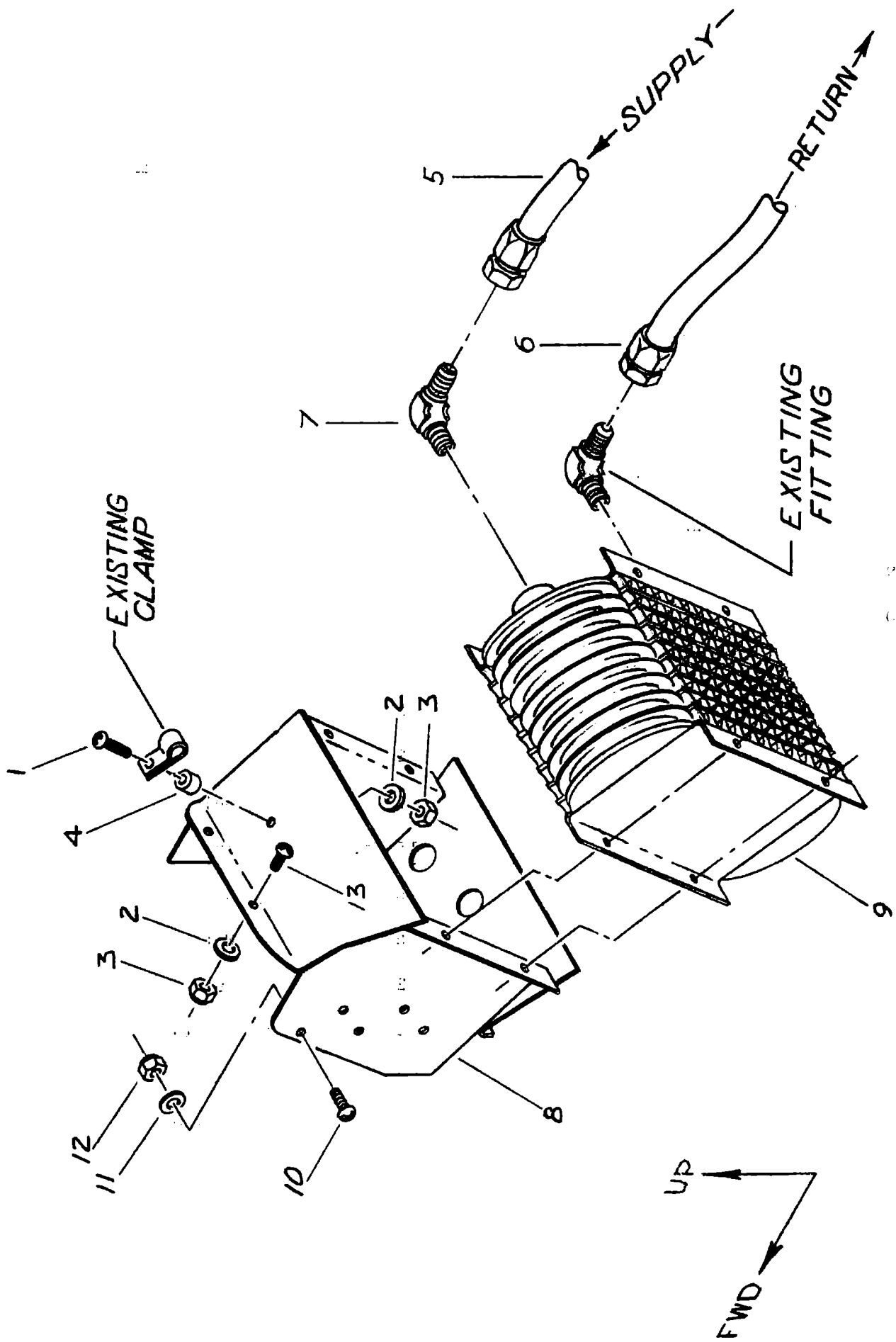

FIG X

TURBO TWIN COMANCHE

XI Pressure Reference System

<u>Item No.</u>	<u>Part Number</u>	<u>No. Reqd. per A/C</u>	<u>Part Name</u>
XI-1	SAE Type E-7	16	Clamp
2	RJ 1630	8	Hose
3	RJ 0625-1	2	Manifold Assy
4	AN742-5C	8	Clamp
5	RJ 0625-2	2	Manifold Assy
6	AN804-3D	2	Tee
7	AN526-6R8	6	Screw
8	AN822-3D	2	Elbow
9	359-3D-0190	2	Hose Assy
10	AN822-2D	2	Elbow
11	359-2D-0240	2	Hose Assy
12	AN826-2D	2	Tee
13	359-2D-0170	2	Hose Assy
14	A200-61-2AN	1	Bulkhead Union
15	NS-4-T	15 Ft.	Tube
16	AN960-6L	6	Washer
17	AN365-632	6	Nut
18	AN924-3D	2	Nut
19	AN936A6	2	Washer
20	AN340-6	2	Nut
21	AN960-616	4	Washer

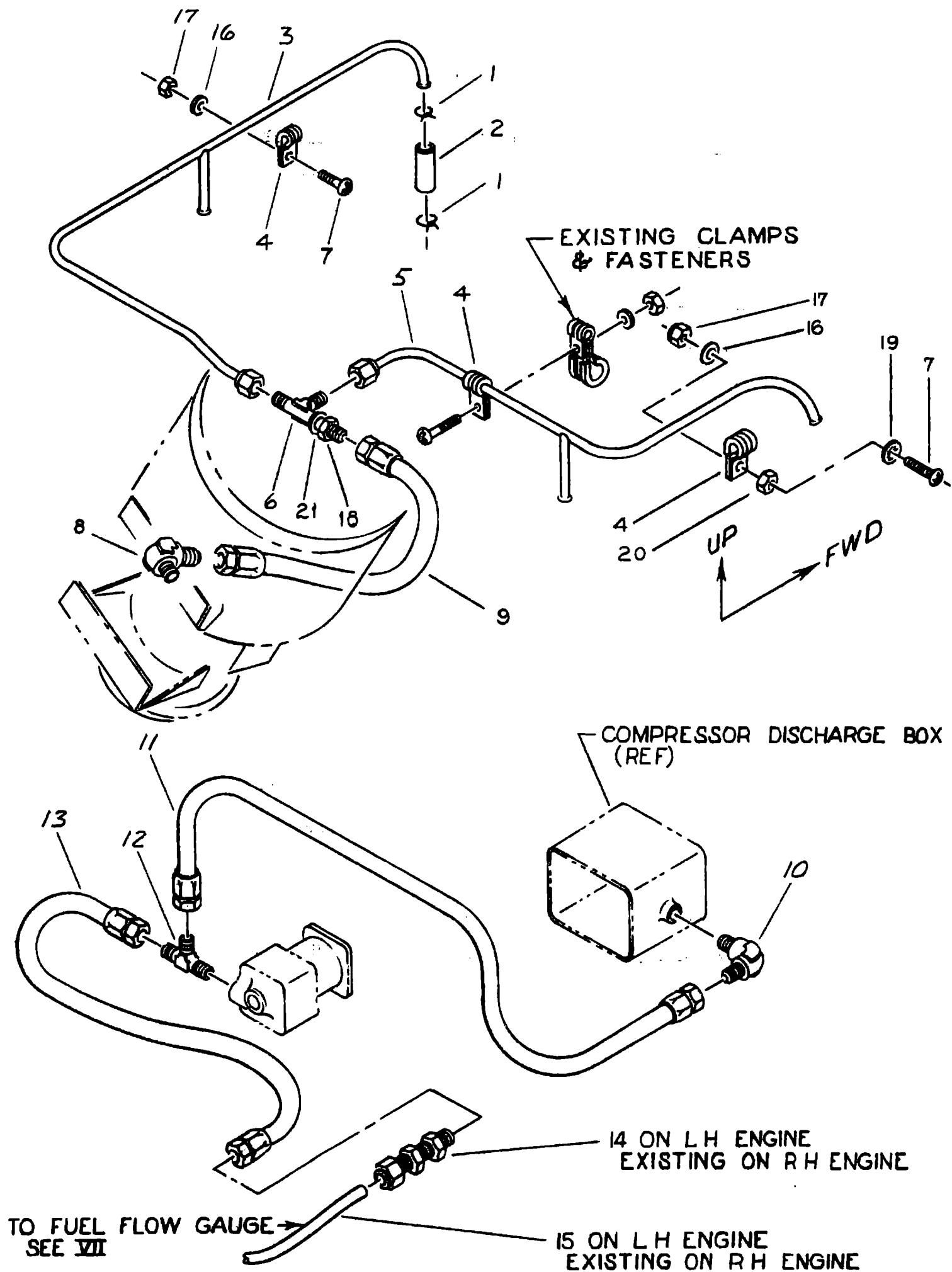

FIG XI

TURBO TWIN COMANCHE

XII Nacelle Parts

<u>Item No.</u>	<u>Part Number</u>	<u>No. Req'd Per A/C</u>	<u>Part Name</u>
XII-1	AN526-10R6	2	Screw
2	AN960-6L	14	Washer
3	RJ 0619-5	4	Plate
4	AN426AD3-4	136	Rivet
5	RJ 0618-3	2	Patch
6	AN526-6R8	14	Screw
7	RJ 0618-5	2	Bracket
8	AN526-8R8	2	Screw
9	AN960-8L	2	Washer
10	AN365-832	8	Nut
11	624000-3-0180	2	Hose Assy
12	AN365-1032	4	Nut
13	AN526-10R8	6	Screw
14	AN960-10	2	Washer
15	RJ 0619-7	2	Plate
16	NAS451-18	2	Button Plug
17	AN526-8R6	6	Screw
18	AN365-632	14	Nut
19	RJ 0619-8	2	Plate
*20	624000-3-0220	2	Hose Assy

*Used only with fuel pressure gauge

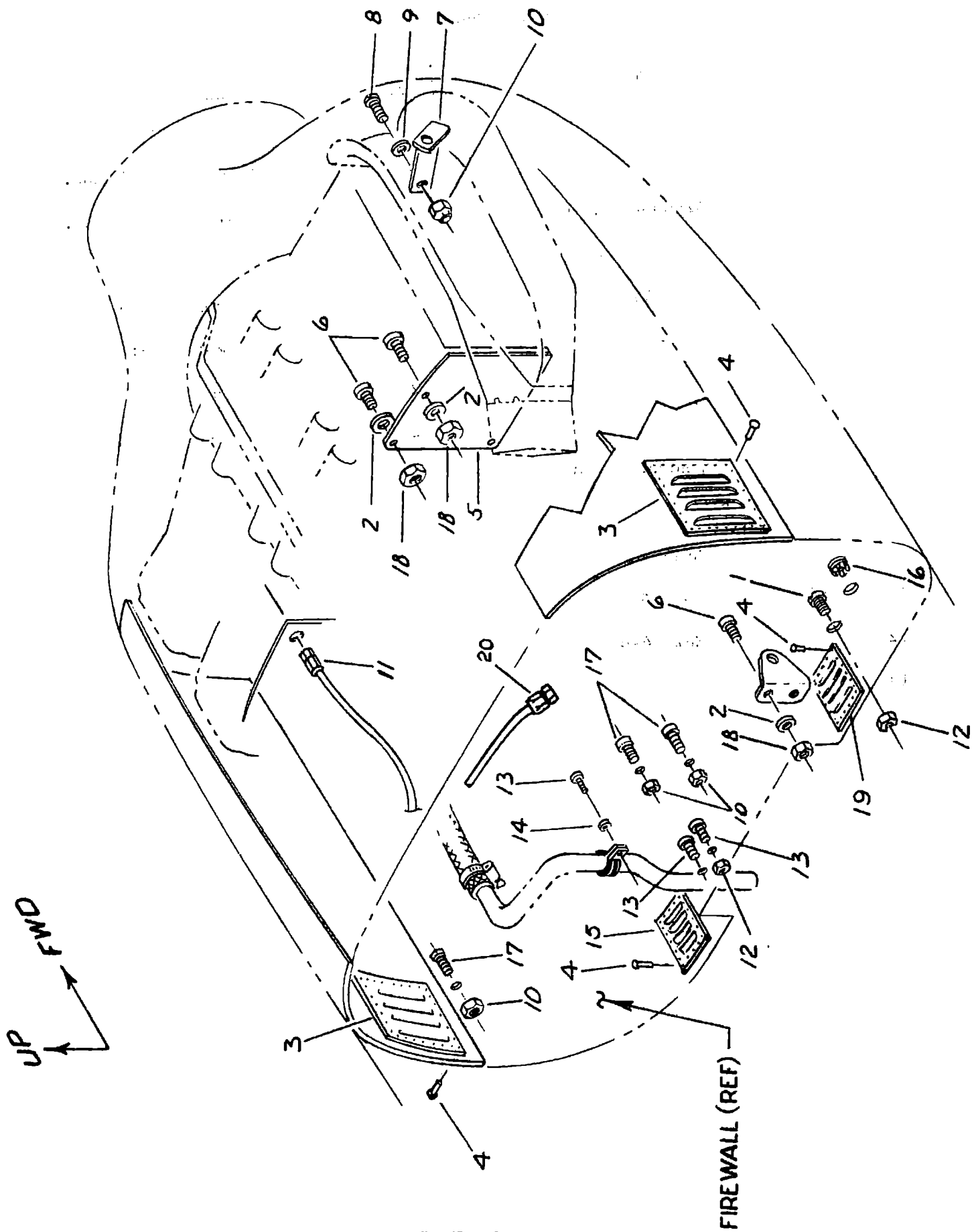

FIG XII

TURBO TWIN COMANCHE

XII Turbocharger Scavenge System

<u>Item No.</u>	<u>Part Number</u>	<u>No. Req'd per A/C</u>	<u>Part Name</u>
XIII-1	RJ 0622	2	Tee Assy
2A	624000-6-0240	1	Hose Assy (RH Eng.)
2B	624000-6-0270	1	Hose Assy (LH Eng.)
3	AN822-6-6D	2	Elbow
4	RJ 1045	2	Scavenge Pump
5	1691-C	4	Gasket (Lyc)
6	RJ 0614	2	Shroud
7	AN816-6-6D	2	Nipple
8	624000-6-0170	2	Hose Assy
9	AN823-6D	2	Elbow
10	AN912-5D	2	Bushing
11	AN822-5-4	2	Elbow
12	AN822-4-4	2	Elbow
13	AN840-4D	2	Nipple

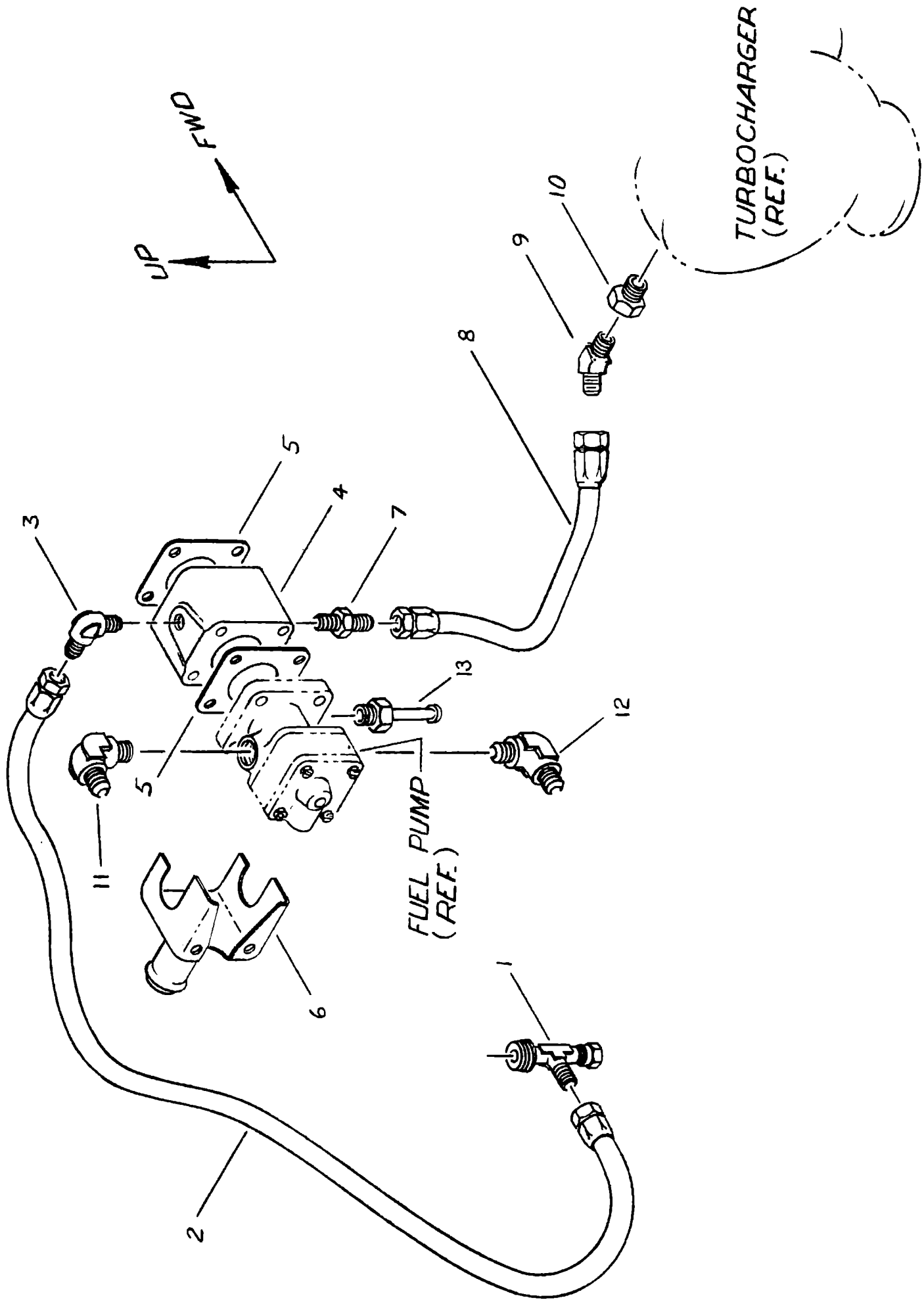

FIG XIII

THIS PAGE LEFT BLANK